



## Eandis System Operator CVBA

*(incorporated as a cooperative company with limited liability (coöperatieve vennootschap met beperkte aansprakelijkheid/société coopérative à responsabilité limitée) in Belgium)*

Public offer in Belgium of 2.000 per cent fixed rate bonds due 23 June 2025

Net yield: 1.153 per cent (on an annual basis)

Yield (gross actuarial return): 1.747 per cent (on an annual basis)

*The yield is calculated on the basis of the issue of the Bonds on the Issue Date, the Issue Price, the interest rate of 2.000 per cent per annum and is based on the assumption that the Bonds will be held until 23 June 2025 when they will be repaid at 100 per cent of their nominal amount in accordance with the Conditions (as defined below). It is not an indication of future yield if the Bonds are not held until their maturity date. The net yield reflects a deduction of Belgian withholding tax at the rate of 30 per cent (investors should consult "Part XII – Taxation" of the Prospectus for further information about Belgian taxation).*

Issue Price: 101.875 per cent

ISIN Code: BE0002285543, Common Code: 162910965

(the "**Bonds**")

for a minimum amount of EUR 150,000,000 and a maximum amount of EUR 200,000,000

unconditionally and irrevocably guaranteed on a several but not joint basis by each of Gaselwest, IMEA, Imewo, Intergem, Iveka, Iverlek and Sibelgas (each a "**Guarantor**" and together the "**Guarantors**") subject to the terms and conditions set out in their respective guarantee (the "**Guarantees**").

**Issue Date: 23 June 2017**

**Subscription Period: from 9 June 2017 until 16 June 2017 included (subject to early closing)**

Application has been made for the Bonds to be admitted to trading on the regulated market of Euronext Brussels.

**These Bonds constitute debt instruments. An investment in the Bonds involves risks. By subscribing to the Bonds, investors lend money to the Issuer who undertakes to pay interest on an annual basis and to reimburse the principal on the maturity date. In case of insolvency or default by the Issuer or any of the Guarantors, however, investors may not recover the amounts they are entitled to and risk losing all or a part of their investment. In addition, the Guarantees are subject to the terms and conditions set out therein and must be called by each individual holder of Bonds. The Bonds are intended for investors who are capable of evaluating the interest rates in light of their knowledge and financial experience. Each decision to invest in these Bonds must be based solely on the information contained in this Prospectus. Investors must read this Prospectus entirely (and in particular "Part II – Risk Factors" on pages 20 to 36 of the Prospectus before making any investment in the Bonds. Each prospective investor must carefully consider whether it is suitable for that investor to invest in the Bonds in light of his knowledge and financial experience and should, if required, obtain professional advice.**

**Joint Lead Managers**



**BNP PARIBAS  
FORTIS**

The date of this Prospectus is 2 June 2017.

Eandis System Operator CVBA, a cooperative company with limited liability (*coöperatieve vennootschap met beperkte aansprakelijkheid/société coopérative à responsabilité limitée*) incorporated under Belgian law, having its registered office at Brusselsesteenweg 199, 9090 Melle, Belgium and registered with the Crossroads Bank for Enterprises (*Kruispuntbank van Ondernemingen/Banque-Carrefour des Entreprises*) under number 0477.445.084 (RLE Ghent, division Ghent) (the "**Issuer**") intends to issue the Bonds for a minimum amount of EUR 150,000,000 and a maximum amount of EUR 200,000,000. The Bonds are offered to the public in Belgium (the "**Public Offer**"). The Bonds will bear interest at the rate of 2.000 per cent per annum, subject to Condition 4 (*Interest and other calculations*). Interest on the Bonds is payable annually in arrear on the Interest Payment Dates (as defined below) falling on, or nearest to, 23 June in each year. The first payment on the Bonds will occur on 23 June 2018 and the last payment on 23 June 2025. The Bonds will mature on 23 June 2025 (the "**Maturity Date**"). All references in this Prospectus to the "**Eandis Economic Group**" refer to the Issuer, its subsidiaries<sup>1</sup> De Stroomlijn CVBA, Atrias CVBA, Synductis CVBA, Warmte@Vlaanderen CVBA and Fluvius CVBA (together: the "**Subsidiaries**") and the Guarantors.

Belfius Bank NV/SA, having its registered office at Pachecolaan 44, 1000 Brussels, Belgium and registered with the Crossroads Bank for Enterprises (*Kruispuntbank van Ondernemingen/Banque-Carrefour des Entreprises*) under number 0403.201.185 ("**Belfius**") and BNP Paribas Fortis NV/SA, having its registered office at Warandeborg 3, 1000 Brussels, Belgium and registered with the Crossroads Bank for Enterprises (*Kruispuntbank van Ondernemingen/Banque-Carrefour des Entreprises*) under number 0403.199.702 ("**BNP Paribas Fortis**") are acting as joint lead managers (each a "**Joint Lead Manager**" and together the "**Joint Lead Managers**") for the purpose of the Public Offer.

The Bonds will be issued in dematerialised form (*gedematerialiseerd/dématérialisé*) in accordance with Article 3, §2 of the Belgian law of 14 December 2005 on the suppression of bearer securities (*Wet houdende afschaffing van de effecten aan toonder/Loi portant suppression des titres au porteur*) and the articles of association of the Issuer and cannot be physically delivered. The Bonds will be represented exclusively by book-entries in the records of the securities settlement system operated by the National Bank of Belgium (the "**NBB**") or any successor thereto (the "**NBB-SSS**"). Access to the NBB-SSS is available through those of its NBB-SSS participants whose membership extends to securities such as the Bonds. NBB-SSS participants include certain banks, stockbrokers (*beursvennootschappen/sociétés de bourse*), Euroclear Bank SA/NV ("**Euroclear**") and Clearstream Banking, *société anonyme*, Luxembourg ("**Clearstream, Luxembourg**"). Accordingly, the Bonds will be eligible for clearance through and will therefore be accepted by Euroclear and Clearstream, Luxembourg. Investors who are not NBB-SSS participants can hold their Bonds within securities accounts in Euroclear and Clearstream, Luxembourg.

The denomination of the Bonds shall be EUR 500 (the "**Specified Denomination**").

The English version of this listing and offering prospectus dated 2 June 2017 (the "**Prospectus**") was approved on 2 June 2017 by the Financial Services and Markets Authority (*Autoriteit voor Financiële Diensten en Markten/Autorité des services et marchés financiers*) (the "**FSMA**") in its capacity as competent authority under Article 23 of the Belgian Law dated 16 June 2006 concerning the public offer of investment securities and the admission of investment securities to trading on a regulated market, as amended (the "**Prospectus Law**"). The approval cannot be considered as a judgment as to the opportunity or the quality of the transaction, nor on the situation of the Issuer or any of the Guarantors and the FSMA gives no undertaking as to the economic and financial soundness of the transaction and the quality or solvency of the Issuer or any of the Guarantors, in line with the provisions of Article 23 of the Prospectus Law. Application has been made to Euronext Brussels for the Bonds to be listed on the regulated market of Euronext Brussels. References in this Prospectus to the Bonds being "listed" (and all related references) shall mean that the Bonds will be listed and admitted to trading on the regulated market of Euronext Brussels. The regulated market of Euronext Brussels is a regulated market for the purposes of Directive 2004/39/EC of the European Parliament and of the Council of 21 April 2004 on markets in financial instruments, as amended (which Directive shall be restated by Directive 2014/65 as of 3 January 2018). Prior to the Public Offer referred to in this Prospectus, there has been no public market for the Bonds.

---

<sup>1</sup> Note that, in this Prospectus, the term "subsidiaries" is used in respect of the Issuer to refer to De Stroomlijn CVBA, Atrias CVBA, Synductis CVBA, Warmte@Vlaanderen CVBA and Fluvius CVBA, although not each of these entities is controlled by the Issuer (within the meaning of article 6 of the Belgian Companies Code).

The Prospectus is a prospectus for the purposes of Article 5(3) of Directive 2003/71/EC of the European Parliament and of the Council of 4 November 2003 on the prospectus to be published when securities are offered to the public or admitted to trading and amending Directive 2001/34/EC, as amended from time to time (the "**Prospectus Directive**") and the Prospectus Law. This Prospectus has been prepared in accordance with the Prospectus Law and Commission Regulation (EC) 809/2004 of 29 April 2004 implementing the Prospectus Directive, as amended from time to time (the "**Prospectus Regulation**"). This Prospectus has been prepared on the basis of Annexes IV, V, VI, XXII (in respect of each of Annex IV, V and VI) and XXX to the Prospectus Regulation.

The Prospectus intends to provide the information with regard to the Issuer, the Guarantors and the Bonds, which according to the particular nature of the Issuer, the Guarantors and the Bonds, is necessary to enable investors to make an informed assessment of the rights attaching to the Bonds and of the assets and liabilities, financial position, profit and losses and prospects of the Issuer and the Guarantors.

An investment in the Bonds involves risks. Potential investors should take note of "*Part II – Risk Factors*" of the Prospectus to understand which factors may affect the Issuer's or the Guarantors' ability to fulfil their respective obligations under the Bonds. In addition, certain factors are material for the purpose of assessing the market risks associated with the Bonds.

Some Joint Lead Managers and their affiliates engage in, or may do so in the future, certain investment banking and/or commercial banking transactions with, and can provide certain services to, the Issuer, the Guarantors and other companies within the Eandis Economic Group within the context of a general commercial relationship. As at the date of the Prospectus, the Joint Lead Managers provide, among others, payment services, investments of liquidities, credit facilities, bank guarantees and assistance in relation to bonds and structured products to the Eandis Economic Group for which certain fees are being paid to the Joint Lead Managers by the Eandis Economic Group. As at 31 December 2016, the existing financial indebtedness of the Eandis Economic Group outstanding towards Belfius Bank SA/NV amounts to EUR 712 million and towards BNP Paribas Fortis SA/NV amounts to EUR 579 million. Potential investors should also be aware that the Joint Lead Managers may hold from time to time debt securities, shares or/and other financial instruments of the Issuer or the Guarantors. Furthermore, the Joint Lead Managers and the Agent receive customary commissions in relation to the Public Offer. Please also refer to the risk factor *Potential conflicts of interest may have an adverse effect* in "*Part II – Risk Factors*".

All references in this document to "**euro**", "**EUR**" and "**€**" refer to the currency introduced at the start of the third stage of the European economic and monetary union pursuant to the Treaty establishing the European Community, as amended.

This Prospectus contains various amounts and percentages which are rounded and, as a result, when these amounts and percentages are added up, they may not total.

## **RESPONSIBLE PERSON**

Each of the Issuer and the Guarantors (having their registered office as specified on the last page of this Prospectus) (the "**Responsible Persons**") accepts responsibility for the Prospectus and any supplements of the Prospectus, **provided that** each of the Guarantors will only be responsible for the information relating to itself and its respective Guarantee.

This Prospectus has been prepared in English and translated into Dutch, and the summary of the Prospectus included in "*Part I – Summary of the Prospectus*" of the Prospectus has been translated into Dutch and French. The Issuer and the Guarantors are responsible for the consistency between the English and the Dutch versions of this Prospectus, provided that each of the Guarantors will only be responsible for the translation of the information relating to itself and its respective Guarantee. The Issuer and the Guarantors are responsible for the consistency between the Dutch, French and the English versions of the summary of this Prospectus, **provided that** each of the Guarantors will only be responsible for the translation of the information relating to itself and its respective Guarantee. Without prejudice to the responsibility of the Issuer and the Guarantors for inconsistencies between the different language versions of the Prospectus or the summary of the Prospectus, in case of inconsistencies between the English and Dutch version of the Prospectus, the English version will prevail. In case of inconsistencies between the English, Dutch and French version of the summary of the Prospectus, the English version will prevail.

To the best of the knowledge and belief of the Issuer and the Guarantors (each of the Guarantors however only with respect to the information for which it is responsible), each having taken all reasonable care to ensure that such is the case, the information contained in this Prospectus is in accordance with the facts and contains no omissions likely to affect its import.

No person is or has been authorised to give any information or to make any representation not contained in or not consistent with this Prospectus and any information or representation not so contained or inconsistent with this Prospectus or any other information supplied in connection with the Bonds and, if given or made, such information must not be relied upon as having been authorised by or on behalf of the Issuer, the Guarantors or the Joint Lead Managers. Neither the delivery of this Prospectus nor any sale made in connection herewith shall, under any circumstances, create any implication that:

- the information contained in this Prospectus is true subsequent to the date of the Prospectus or otherwise that there has been no change in the affairs of the Issuer, the Guarantors or their subsidiaries since the date hereof or the date upon which this Prospectus has been most recently amended and/or supplemented;
- that there has been no adverse change, or any event likely to involve any adverse change, in the condition (financial or otherwise) of the Issuer, the Guarantors or their subsidiaries since the date hereof or, if later, the date upon which this Prospectus has been most recently amended and/or supplemented; or
- that the information contained in it or any other information supplied in connection with the Bonds is correct at any time subsequent to the date on which it is supplied or, if different, the date indicated in the document containing the same

in each case, without prejudice to the obligation the Issuer may have to publish a supplement to the Prospectus in accordance with the Prospectus Law (in respect of which please see under "*Warnings*" below").

None of the Joint Lead Managers or their respective affiliates has authorised the whole or any part of this Prospectus and none of them makes any representation or warranty or accepts any responsibility as to the accuracy or completeness of the information contained in this Prospectus. Neither the delivery of this Prospectus nor the offering, sale or delivery of any Bond shall in any circumstances create any implication that there has been no adverse change, or any event reasonably likely to involve any adverse change, in the condition (financial or otherwise) of the Issuer since the date of this Prospectus.

No Joint Lead Manager accepts any liability, whether contractual or extra-contractual or otherwise, in relation to the information contained, implied or incorporated by reference in this Prospectus or any other information in connection with the Issuer, the offering of the Bonds or the distribution of the Bonds.

The Joint Lead Managers, the Issuer and the Guarantors expressly do not undertake to review the condition (financial or otherwise) of the Issuer, the Guarantors and their subsidiaries during the life of the Bonds nor to provide any update of the information made available, without prejudice to the obligation the Issuer and/or the Guarantors may have during the period between the date of this Prospectus and the final closure of the Public Offer, or, if applicable, the time at which trading on the regulated market of Euronext Brussels begins, to publish a supplement to the Prospectus in accordance with the Prospectus Law (in respect of which please see under "*Warnings*" below").

Neither this Prospectus nor any other information supplied in connection with the offering of the Bonds (a) is intended to provide the basis of any credit or other evaluation or (b) should be considered as a recommendation by the Issuer or the Joint Lead Managers that any recipient of this Prospectus or any other information supplied in connection with the offering of the Bonds should purchase any Bonds. Each investor contemplating a purchase of the Bonds should make its own independent investigation of the financial condition and affairs, and its own appraisal of the creditworthiness, of the Issuer and the Guarantors.

#### **PUBLIC OFFER IN BELGIUM**

This Prospectus has been prepared in connection with the Public Offer and with the admission to trading on the regulated market of Euronext Brussels. This Prospectus has been prepared on the basis that any

offer of Bonds in any Member State of the European Economic Area which has implemented the Prospectus Directive (each a "**Relevant Member State**") other than offers in Belgium (the "**Permitted Public Offer**"), will be made pursuant to an exemption under the Prospectus Directive, as implemented in that Relevant Member State, from the requirement to publish a prospectus for offers of Bonds. Accordingly any person making or intending to make an offer in that Relevant Member State of Bonds that are the subject of the offering contemplated in this Prospectus, other than the Permitted Public Offer, may only do so in circumstances in which no obligation arises for the Issuer or the Joint Lead Managers to publish a prospectus pursuant to Article 3 of the Prospectus Directive or supplement a prospectus pursuant to Article 16 of the Prospectus Directive, in each case, in relation to such offer. Neither the Issuer nor the Joint Lead Managers have authorised, nor do they authorise, the making of any offer (other than the Permitted Public Offer) of Bonds in circumstances in which an obligation arises for the Issuer or the Joint Lead Managers to publish or supplement a prospectus for such offer.

This Prospectus does not constitute an offer to sell or the solicitation of an offer to buy the Bonds in any jurisdiction to any person to whom it is unlawful to make the offer or solicitation in such jurisdiction. The distribution of this Prospectus and the offer or sale of Bonds may be restricted by law in certain jurisdictions. The Issuer and the Joint Lead Managers do not represent that this Prospectus may be lawfully distributed, or that the Bonds may be lawfully offered, in compliance with any applicable registration or other requirements in any such jurisdiction, or pursuant to an exemption available thereunder, or assume any responsibility for facilitating any such distribution or offering. In particular, no action has been taken by the Issuer or the Joint Lead Managers which is intended to permit a public offering of the Bonds or the distribution of this Prospectus in any jurisdiction (other than Belgium) where action for that purpose is required. Accordingly, no Bonds may be offered or sold, directly or indirectly, and neither this Prospectus nor any advertisement or other offering material may be distributed or published in any jurisdiction, except under circumstances that will result in compliance with any applicable laws and regulations. Persons into whose possession this Prospectus or any Bonds may come must inform themselves about, and observe, any such restrictions on the distribution of this Prospectus and the offering and sale of Bonds.

This Prospectus is to be read in conjunction with all the documents which are incorporated herein by reference (see "*Part III – Documents incorporated by reference*") and each supplement. This Prospectus shall be read and construed on the basis that such documents are incorporated in, and form part of, the Prospectus.

The Issuer and the Guarantors authorise that this Prospectus may be used for the purposes of the Public Offer until the last day of the subscription period, which runs from 9 June 2017 until 16 June 2017 included (the "**Subscription Period**") (regardless of a possible early termination as specified in "*Part XIII – Subscription and sale*") in Belgium, by any financial intermediary (other than the Joint Lead Managers) authorised pursuant to Directive 2004/39/EC to conduct such offers (each an "**Authorised Offeror**").

**Any Authorised Offeror (other than the Joint Lead Managers) envisaging to use this Prospectus in connection with a Permitted Public Offer is obliged to state on its website, during the relevant Subscription Period, that this Prospectus is used for a Permitted Public Offer with the authorisation of the Issuer and the Guarantors in accordance with the relevant applicable conditions.**

If, during the period for which the Issuer and the Guarantors are authorised to use this Prospectus, a public offer was made in Belgium, each of the Issuer and the Guarantors accepts responsibility for the content of this Prospectus as set out below, **provided that** each of the Guarantors will only be responsible for the information relating to itself and its respective Guarantee. Neither the Issuer and the Guarantors, nor the Joint Lead Managers can be held responsible or liable for any act or omission from any Authorised Offeror, including compliance with any rules of conduct or other legal or regulatory requirements under or in connection with such public offer.

Neither the Issuer and the Guarantors, nor the Joint Lead Managers have authorised any public offer of the Bonds by any person in any circumstance and such person is under no circumstance authorised to use this Prospectus in connection with a public offer of the Bonds, unless (i) the public offer is made by an Authorised Offeror in Belgium, or (ii) the public offer is made pursuant to an exemption from the requirement to publish a prospectus under the Prospectus Directive. Any such unauthorised public offer is not made by or on behalf of the Issuer, the Guarantors or the Joint Lead Managers and neither the Issuer

and the Guarantors, nor the Joint Lead Managers can be held responsible or liable for the actions of any such person engaging in such unauthorised public offers.

**Each offer and each sale of the Bonds by an Authorised Offeror will be made in accordance with the terms and conditions agreed between such Authorised Offeror and the investor, including in relation to the price, the allocation and the costs and/or taxes to be borne by an investor. Neither the Issuer, nor the Guarantors are a party to any arrangements or terms and conditions in connection with the offer and sale of the Bonds between the Authorised Offeror and an investor. This Prospectus does not contain the terms and conditions of any Authorised Offeror. The terms and conditions of the Joint Lead Managers are however included in this Prospectus (see "Part IV – Terms and conditions of the Bonds"). The terms and conditions in connection with the offer and sale of the Bonds will be provided to any investor by an Authorised Offeror during the Subscription Period. Neither the Issuer and the Guarantors, nor the Joint Lead Managers can be held responsible or liable for the terms and conditions of any Authorised Offeror (or any information provided by such Authorised Offeror in respect thereof).**

The Bonds have not been and will not be registered under the United States Securities Act of 1933, as amended (the "**Securities Act**") and, subject to certain exceptions, may not be offered or sold within the United States. For a further description of certain restrictions on the offering and sale of the Bonds and on the distribution of this document, please refer to "*Part XIII – Subscription and sale*".

## **WARNINGS**

The Prospectus has been prepared to provide information on the Public Offer. When potential investors decide to invest in the Bonds, they should base this decision on the information set out in this Prospectus and, as the case may be, on their own research of the Issuer, the Guarantors and the terms and conditions of the Bonds set out in "*Part IV – Terms and conditions of the Bonds*" (the "**Conditions**"), including, but not limited to, the associated benefits and risks, as well as the conditions of the Public Offer itself. The investors must themselves assess, with their own advisors if necessary, whether the Bonds are suitable for them, considering their personal income and financial situation. In case of any doubt about the risk involved in purchasing the Bonds, investors should abstain from investing in the Bonds.

The summaries and descriptions of legal provisions, taxation, accounting principles or comparisons of such principles, legal company forms or contractual relationships reported in the Prospectus may in no circumstances be interpreted as investment, legal or tax advice for potential investors. Potential investors are urged to consult their own advisor, accountant or other advisors concerning the legal, tax, economic, financial and other aspects associated with the subscription to the Bonds.

In the event of important new developments, material errors or inaccuracies that could affect the assessment of the Bonds, and which occur or are identified between the time of the approval of the Prospectus and the final closure of the Public Offer, or, if applicable, the time at which trading on the regulated market of Euronext Brussels commences, the Issuer will publish a supplement to the Prospectus containing this information in accordance with Article 34, §1 of the Prospectus Law.

This supplement will (i) need to be approved by the FSMA and (ii) be published in compliance with at least the same laws and regulations applicable to the Prospectus, and will be published on the websites of the Issuer (within the section addressed to investors as "Investor Relations" ([www.eandis.be](http://www.eandis.be)), Belfius ([www.belfius.be/eandis](http://www.belfius.be/eandis)), BNP Paribas Fortis ([www.bnpparibasfortis.be](http://www.bnpparibasfortis.be)) and the website of the FSMA ([www.fsma.be](http://www.fsma.be)). The Issuer must ensure that any such supplement is published as soon as possible after the occurrence of such new significant factor. Investors who have already agreed to purchase or subscribe to Bonds before the publication of the supplement to the Prospectus have the right to withdraw their agreement during a period of two business days commencing on the day after the publication of the supplement.

## **MARKET AND INDUSTRY INFORMATION**

The statements in this Prospectus with respect to market and other industry data have been accurately reproduced from independent industry publications and reports by research firms or other published independent sources and, as far as the Issuer is aware and is able to ascertain from such sources, no facts have been omitted which would render such information inaccurate or misleading.

## FORWARD LOOKING STATEMENTS

This Prospectus contains statements that constitute estimates and forward-looking statements. These statements appear in a number of places in this Prospectus, including but not limited to the sections 'Summary of the Prospectus', 'Risk Factors' and 'Description of the Issuer and the Guarantors', and include statements regarding the Issuer's and the Guarantors' intent, belief or current expectations, and those of the Issuer's and the Guarantors' officers, with respect to (among other things) their financial condition. Such estimates and forward-looking statements are based mainly on current expectations and estimates of future events and trends which affect, or may affect, the Issuer's and the Guarantors' business and results of operations. Although the Issuer and the Guarantors believe that these estimates and forward-looking statements are based upon reasonable assumptions, they are subject to several risks and uncertainties and are based on information currently available to the Issuer and the Guarantors.

The words "believe", "may", "may have", "might", "would", "estimate", "continue", "anticipate", "intend", and similar words are intended to identify estimates and forward-looking statements. Estimates and forward-looking statements refer only to the date when they were made and neither the Issuer and the Guarantors nor the Joint Lead Managers undertake any obligation to update or review any estimate or forward-looking statement whether as a result of new information, future events or any other factors. Estimates and forward-looking statements involve risks and uncertainties and do not guarantee future performance, as actual results or developments may be substantially different from the expectations described in the forward-looking statements. In light of the risks and uncertainties described above, the events referred to in the estimates and forward-looking statements included in this Prospectus may or may not occur and the Issuer's and the Guarantors' business performance and results of operations may differ materially from those expressed in such estimates and forward-looking statements due to factors that include but are not limited to those mentioned above. Investors are warned not to place undue reliance on any estimates or forward-looking statements in making decisions regarding investment in the Bonds.

## AVAILABILITY OF THE PROSPECTUS

This Prospectus will be published in English on the website of the FSMA ([www.fsma.be](http://www.fsma.be)). The Prospectus will also be available in English and Dutch on the website of the Issuer ([www.eandis.be](http://www.eandis.be)) in the section addressed to investors as Investor Relations and on the website of Belfius ([www.belfius.be/eandis](http://www.belfius.be/eandis)) and BNP Paribas Fortis ([www.bnpparibasfortis.be](http://www.bnpparibasfortis.be)). A hard copy of the Prospectus can be obtained free of charge at the registered office of the Issuer (Brusselsesteenweg 199, 9090 Melle; +32 (0)9 263 45 04), Belfius (Pachecolaan 44, 1000 Brussels; +32 (0)2 250 70 10) and BNP Paribas Fortis (Warandeberg 3, 1000 Brussels; +32 2 433 41 34).

## FURTHER INFORMATION

For more information about the Issuer, please contact:

Eandis System Operator CVBA  
Brusselsesteenweg 199  
9090 Melle  
Belgium  
Tel.: +32 (0)9 263 45 04  
E-mail: [investors@eandis.be](mailto:investors@eandis.be)  
[www.eandis.be](http://www.eandis.be)

## CONTENTS

	<b>Page</b>
PART I – SUMMARY OF THE PROSPECTUS .....	1
PART II – RISK FACTORS .....	20
PART III – DOCUMENTS INCORPORATED BY REFERENCE .....	37
PART IV – TERMS AND CONDITIONS OF THE BONDS .....	38
PART V – SETTLEMENT .....	51
PART VI – FORM OF THE GUARANTEE .....	52
PART VII DESCRIPTION OF THE BELGIAN ELECTRICITY AND GAS MARKET .....	55
PART VIII REGULATORY FRAMEWORK APPLICABLE TO THE FLEMISH DSOS .....	63
PART IX – DESCRIPTION OF THE ISSUER AND THE GUARANTORS .....	77
PART X – SELECTED FINANCIAL INFORMATION.....	118
PART XI – USE OF PROCEEDS.....	128
PART XII – TAXATION.....	129
PART XIII– SUBSCRIPTION AND SALE .....	135
PART XIV – GENERAL INFORMATION .....	144
ANNEX 1 INDEX OF DEFINED TERMS .....	146
ANNEX 2 CONSOLIDATED FINANCIAL STATEMENTS EANDIS ECONOMIC GROUP FOR THE FINANCIAL YEAR ENDED 31 DECEMBER 2016.....	149
ANNEX 3 CONSOLIDATED FINANCIAL STATEMENTS EANDIS ECONOMIC GROUP FOR THE FINANCIAL YEAR ENDED 31 DECEMBER 2015.....	221
ANNEX 4 BALANCE SHEET AND INCOME STATEMENT OF EACH GUARANTOR .....	287



## PART I – SUMMARY OF THE PROSPECTUS

The Summary has been prepared in accordance with the content and format requirements of the Prospectus Regulation.

Summaries are made up of disclosure requirements known as 'Elements'. These elements are numbered in Sections A – E (A.1 – E.7). This Summary contains all the Elements required to be included in a summary for this type of securities, issuer and guarantors. Because some Elements are not required to be addressed, there may be gaps in the numbering sequence of the Elements.

Even though an Element may be required to be inserted in the Summary because of the nature of the Bonds, the Issuer and Guarantors, it is possible that no relevant information can be given regarding the Element. In this case a short description of the Element is included in the summary with the mention of 'not applicable'.

Words and expressions defined in "*Part IV – Terms and conditions of the Bonds*" of the Prospectus shall have the same meaning in this Summary.

<b>Section A – Introduction and warnings</b>		
A.1	<b>Introduction and warnings</b>	<p>This summary should be read as an introduction to the Prospectus. Any decision to invest in the Bonds should be based on a consideration of the Prospectus as a whole by the investor.</p> <p>Where a claim relating to the information contained in the Prospectus is brought before a court, the plaintiff investor might, under the national legislation of the Member States, have to bear the costs of translating the Prospectus before the legal proceedings are initiated. Civil liability attaches only to those persons who have tabled the Summary, including any translation thereof, but only if the Summary is misleading, inaccurate or inconsistent when read together with the other parts of the Prospectus or it does not provide, when read together with the other parts of the Prospectus, key information in order to aid investors when considering whether to invest in the Bonds.</p>
A.2	<b>Consent to use the Prospectus for subsequent resale or final placement by financial intermediaries and conditions attached to such consent</b>	<p><i>Consent:</i> The Issuer and the Guarantors authorise that this Prospectus may be used for the purposes of a public offer in Belgium of 2.000 per cent fixed rate bonds due 23 June 2025, for a minimum amount of EUR 150,000,000 and a maximum amount of EUR 200,000,000 (the "<b>Public Offer</b>"), by any financial intermediary (other than the Joint Lead Managers) authorised pursuant to Directive 2004/39/EC to conduct such offers (each an "<b>Authorised Offeror</b>").</p> <p><i>Offer Period:</i> The Issuer and the Guarantors authorise that this Prospectus may be used from 9 June 2017 until 16 June 2017 included (regardless of a possible early closing of the Subscription Period).</p> <p><i>Conditions to consent:</i> The Issuer and the Guarantors authorise that this Prospectus may be used for the purpose of a public offer in Belgium.</p>

Section A – Introduction and warnings		
		<p>Each offer and each sale of the Bonds by an Authorised Offeror will be made in accordance with the terms and conditions agreed between such Authorised Offeror and the investor, including in relation to the price, the allocation and the costs and/or taxes to be borne by an investor. Neither the Issuer, nor any of the Guarantors is a party to any arrangements or terms and conditions in connection with the offer and sale of the Bonds between the Authorised Offeror and an investor. This Prospectus does not contain the terms and conditions of any Authorised Offeror (other than the Joint Lead Managers). The terms and conditions in connection with the offer and sale of the Bonds will be provided to any investor by an Authorised Offeror (other than the Joint Lead Managers) at the relevant time during the Subscription Period commencing 9 June 2017 and ending 16 June 2017. Neither the Issuer and the Guarantors, nor the Joint Lead Managers can be held responsible or liable for the terms and conditions of any Authorised Offeror (or any information provided by such Authorised Offeror in respect thereof).</p>

Section B – Issuer and Guarantors		
B.1	<b>Legal and commercial name of the Issuer</b>	Eandis System Operator CVBA/ EANDIS (the " <b>Issuer</b> " or " <b>Eandis System Operator</b> ")
B.2	<b>Domicile/legal form/ legislation/country of incorporation</b>	Eandis System Operator CVBA is a limited liability partnership (" <i>coöperatieve vennootschap met beperkte aansprakelijkheid</i> " / " <i>société coopérative à responsabilité limitée</i> "), incorporated in Belgium and subject to the laws of Belgium. The Issuer has its registered seat at Brusselsesteenweg 199, B-9090 Melle, Belgium.
B.4b	<b>Trend information</b>	<p>The increase in decentralized electricity production in the Flemish market will continue. This will lead to continued pressure on the distribution system operators ("<b>DSOs</b>") and their operating companies to adapt the distribution grids. In addition, smart metering will remain of significant importance, pushing the distribution sector to formulate a general strategy on smart metering and an implementation plan. As to the tariffs, there is a growing concern among the general public about rising energy tariffs which will force the DSOs to further keep a tight rein on their costs. Against the backdrop described above, Eandis will continue to monitor trends in the energy market in Belgium and abroad and, if needed, adapt its strategy accordingly.</p> <p>Eandis System Operator and Infrax announced on 11 May 2017 the start of a process that will eventually lead to a complete integration of Eandis System Operator and Infrax under the name "Fluvius". The latter is to become the new multi-utility operator for the entire Flemish Region.</p>
B.5	<b>Description of the Issuer within the group</b>	The Issuer is part of the so-called "Eandis economic group". The Eandis economic group (the " <b>Eandis Economic Group</b> " consists of the Issuer, its subsidiaries <sup>2</sup> (De Stroomlijn CVBA (" <b>De Stroomlijn</b> "),

<sup>2</sup> Note that, in this Prospectus, the term "subsidiaries" is used in respect of the Issuer to refer to De Stroomlijn CVBA, Atrias CVBA, Synductis CVBA, Warmte@Vlaanderen CVBA and Fluvius CVBA, although not each of these entities is controlled by the Issuer (within the meaning of article 6 of the Belgian Companies Code).

## Section B – Issuer and Guarantors

Atrias CVBA ("**Atrias**"), Synductis CVBA ("**Synductis**"), Warmte@Vlaanderen CVBA ("**Warmte@Vlaanderen**") and Fluvius CVBA ("**Fluvius**") (together: the "**Subsidiaries**") and the seven Guarantors (as defined below) for the distribution of electricity and gas.

The notion of an "Eandis Economic Group" is relevant as this allows to present to stakeholders, including investors, a global picture of both the financial situation and developments of the operating company (i.e. the Issuer and its subsidiaries) and the asset owners of the energy distribution grids (i.e. the seven Guarantors) as a whole.

The Issuer develops, manages and maintains low voltage and mid voltage distribution networks for electricity as well as low pressure and mid pressure distribution networks for gas, owned by the Guarantors.

An overview of the Eandis Economic Group is set out below:

### Eandis Economic Group's Structure

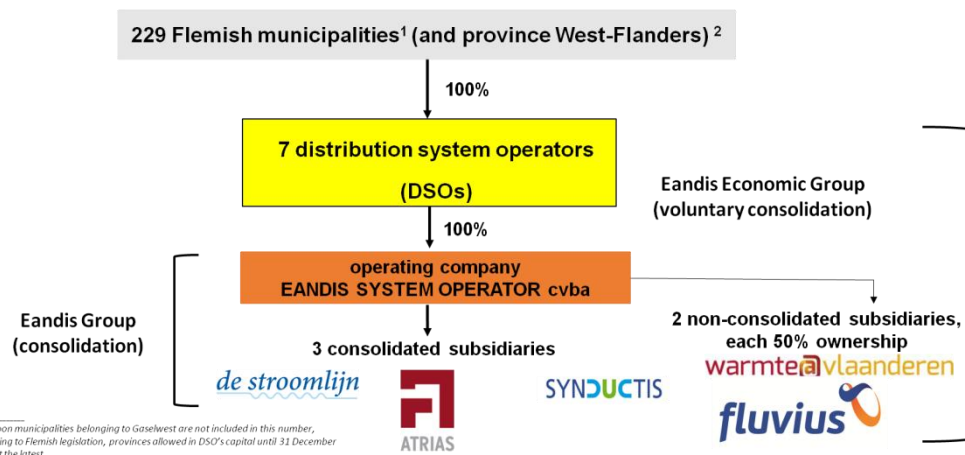

B.9	<b>Profit forecast or estimate</b>	Not applicable. The Issuer does not provide profit forecasts															
B.10	<b>Audit report qualifications</b>	Not applicable. There are no qualifications in the Audit Reports to the Annual Report 2016 and the Annual Report 2015 for the Issuer.															
B.12	<b>Selected historical key financial information of the Issuer (consolidated)</b>	<p>The scope of consolidation is the Issuer as consolidating entity and Atrias, De Stroomlijn, Indexis (only for the period until 31 December 2015) and Synductis as consolidated entities. Warmte@Vlaanderen and Fluvius have not been included in the consolidation as they were, as at 31 December 2016, not yet operational (the participation of the Issuer is registered as "investment in other companies").</p> <table style="width: 100%; border-collapse: collapse;"> <thead> <tr> <th colspan="3" style="text-align: center; border-top: 1px solid black; border-bottom: 1px solid black;">Statement of Financial Position</th> </tr> <tr> <th style="text-align: left; border-bottom: 1px solid black;">Eandis System Operator (consolidated) (IFRS)</th> <th style="text-align: center; border-bottom: 1px solid black;">As of 31 December 2016</th> <th style="text-align: center; border-bottom: 1px solid black;">As of 31 December 2015</th> </tr> </thead> <tbody> <tr> <td colspan="3" style="text-align: center;"><i>in 1000 EUR</i></td> </tr> <tr> <td>Total assets.....</td> <td style="text-align: right;">4,352,389</td> <td style="text-align: right;">4,206,595</td> </tr> <tr> <td>Non-current assets .....</td> <td style="text-align: right;">3,534,199</td> <td style="text-align: right;">3,756,646</td> </tr> </tbody> </table>	Statement of Financial Position			Eandis System Operator (consolidated) (IFRS)	As of 31 December 2016	As of 31 December 2015	<i>in 1000 EUR</i>			Total assets.....	4,352,389	4,206,595	Non-current assets .....	3,534,199	3,756,646
Statement of Financial Position																	
Eandis System Operator (consolidated) (IFRS)	As of 31 December 2016	As of 31 December 2015															
<i>in 1000 EUR</i>																	
Total assets.....	4,352,389	4,206,595															
Non-current assets .....	3,534,199	3,756,646															

<b>Section B – Issuer and Guarantors</b>																																																		
		<table> <tr> <td>Current assets .....</td> <td style="text-align: right;">818,190</td> <td style="text-align: right;">449,949</td> </tr> <tr> <td>Total liabilities.....</td> <td style="text-align: right;">4,352,389</td> <td style="text-align: right;">4,206,595</td> </tr> <tr> <td>Equity .....</td> <td style="text-align: right;">1,099</td> <td style="text-align: right;">1,099</td> </tr> <tr> <td>Non-current liabilities .....</td> <td style="text-align: right;">3,506,515</td> <td style="text-align: right;">3,726,010</td> </tr> <tr> <td>Current liabilities .....</td> <td style="text-align: right;">844,775</td> <td style="text-align: right;">479,486</td> </tr> <tr> <td colspan="3" style="text-align: center;"><b>Statement of profit or loss</b></td> </tr> <tr> <td></td> <td style="text-align: center;"><b>Year ended 31 December 2016</b></td> <td style="text-align: center;"><b>Year ended 31 December 2015</b></td> </tr> <tr> <td>Operating revenue.....</td> <td style="text-align: right;">998,121</td> <td style="text-align: right;">1,044,062</td> </tr> <tr> <td>Operating expenses .....</td> <td style="text-align: right;">-978,829</td> <td style="text-align: right;">-1,023,479</td> </tr> <tr> <td>Result for the period.....</td> <td style="text-align: right;">0</td> <td style="text-align: right;">0</td> </tr> <tr> <td colspan="3" style="text-align: center;"><b>Cash flow statement</b></td> </tr> <tr> <td></td> <td style="text-align: center;"><b>Year ended 31 December 2016</b></td> <td style="text-align: center;"><b>Year ended 31 December 2015</b></td> </tr> <tr> <td>Cash flow from/used in operating activities .....</td> <td style="text-align: right;">-12,819</td> <td style="text-align: right;">743,463</td> </tr> <tr> <td>Cash flow from/used in investing activities .....</td> <td style="text-align: right;">-730</td> <td style="text-align: right;">-145</td> </tr> <tr> <td>Cash flow from/used in financing activities .....</td> <td style="text-align: right;">12,576</td> <td style="text-align: right;">-747,589</td> </tr> <tr> <td>Net change in cash and cash equivalents .....</td> <td style="text-align: right;">-973</td> <td style="text-align: right;">-5,271</td> </tr> </table> <p>There has been no significant change in the financial or trading position of the Issuer since 31 December 2016 and no material adverse change in the Issuer's prospects since 31 December 2016.</p>	Current assets .....	818,190	449,949	Total liabilities.....	4,352,389	4,206,595	Equity .....	1,099	1,099	Non-current liabilities .....	3,506,515	3,726,010	Current liabilities .....	844,775	479,486	<b>Statement of profit or loss</b>				<b>Year ended 31 December 2016</b>	<b>Year ended 31 December 2015</b>	Operating revenue.....	998,121	1,044,062	Operating expenses .....	-978,829	-1,023,479	Result for the period.....	0	0	<b>Cash flow statement</b>				<b>Year ended 31 December 2016</b>	<b>Year ended 31 December 2015</b>	Cash flow from/used in operating activities .....	-12,819	743,463	Cash flow from/used in investing activities .....	-730	-145	Cash flow from/used in financing activities .....	12,576	-747,589	Net change in cash and cash equivalents .....	-973	-5,271
Current assets .....	818,190	449,949																																																
Total liabilities.....	4,352,389	4,206,595																																																
Equity .....	1,099	1,099																																																
Non-current liabilities .....	3,506,515	3,726,010																																																
Current liabilities .....	844,775	479,486																																																
<b>Statement of profit or loss</b>																																																		
	<b>Year ended 31 December 2016</b>	<b>Year ended 31 December 2015</b>																																																
Operating revenue.....	998,121	1,044,062																																																
Operating expenses .....	-978,829	-1,023,479																																																
Result for the period.....	0	0																																																
<b>Cash flow statement</b>																																																		
	<b>Year ended 31 December 2016</b>	<b>Year ended 31 December 2015</b>																																																
Cash flow from/used in operating activities .....	-12,819	743,463																																																
Cash flow from/used in investing activities .....	-730	-145																																																
Cash flow from/used in financing activities .....	12,576	-747,589																																																
Net change in cash and cash equivalents .....	-973	-5,271																																																
B.13	<b>Events impacting the Issuer's solvency</b>	Not applicable. There are no material events particular to the Issuer which are to a material extent relevant to the Issuer's solvency.																																																
B.14	<b>Dependence of the Issuer upon other entities of the group</b>	<p>Please also refer to Element B.5 above "<i>Description of the Issuer within the group</i>". As the distribution grid operated by the Issuer is owned by the Guarantors, the Issuer is dependent on the Guarantors.</p> <p>The Guarantors have entrusted the operational management of their grids to the Issuer who acts as operating company ("<i>werkmaatschappij</i>") and charges the Guarantors at cost for its services. The Issuer is also responsible for attracting financing on behalf and for the account of the Guarantors. Therefore, the Issuer acts as issuer of bonds and related capital markets debt instruments for the Guarantors. Bank loans and related bank debt instruments are directly contracted by the Guarantors. Where the proceeds of bonds and related debt instruments are to be used to finance investments in the grids of the Guarantors, these are on-lent by the Issuer to the Guarantors.</p>																																																
B.15	<b>Principal activities of the Issuer</b>	The Issuer develops, manages and maintains low voltage and mid voltage distribution networks for electricity as well as low pressure and mid pressure distribution networks for gas, owned by the Guarantors, which are also the holders of the DSO licence granted by the VREG. The Issuer invoices each Guarantor on a monthly basis for its services, at cost without any profit margin. The Guarantors directly invoice their customers (i.e. the suppliers of electricity and gas) for their use of the distribution grids for electricity and gas.																																																
B.16	<b>Controlling shareholders</b>	The Guarantors are the Issuer's sole shareholders. No shareholder exercises control (within the meaning of the Belgian Companies Code) over the Issuer (including, due to the absence of a																																																

<b>Section B – Issuer and Guarantors</b>		
		shareholders' agreement, any joint control). The Issuer is the consolidating entity for the accounts of its subsidiaries De Stroomlijn CVBA, Atrias CVBA and Synductis CVBA.
B.17	<b>Solicited credit ratings</b>	<p>Moody's Investor Service Ltd. has assigned a corporate rating A3 ('stable outlook') to the Issuer on 14 December 2016. On 14 December 2016, Moody's Investor Services Ltd. downgraded the Issuer's rating from A1 (negative outlook) to A3 (stable outlook). This was mainly because of Moody's anticipation that certain measures that were contemplated earlier to improve the Issuer's credit quality would not be implemented following the cancellation of the process for an entry of a private partner in the capital of the Guarantors and the corresponding capital increase. This made a near-term strengthening of the Issuer's balance sheet unlikely from their perspective. In addition, the rating agency re-assessed the support assumptions embedded in the Issuer's long-term ratings. The rating has not been changed since then.</p> <p>Creditreform Rating AG has assigned a corporate rating A+ ('stable outlook') to the Issuer on 18 January 2017 for the first time. The rating has not been changed since then.</p> <p>The Bonds will not be rated by Moody's or any other rating agency.</p>
B.18	<b>Description of the nature and the scope of the Guarantees</b>	Each of the Guarantors irrevocably and unconditionally guarantees, on a several but not joint basis, the due and punctual payment and performance of all moneys, obligations and liabilities owed or incurred by the Issuer to the Bondholders in respect of the Bonds, whether actual, future or contingent and whether or not the Bondholder has acquired the Bond on the Issue Date or at a later stage, <i>pro rata</i> in accordance to the shares each Guarantor holds in the share capital of the Issuer as of the date of the issue of the Bonds. The obligations of each Guarantor under the Guarantee are direct, unconditional, unsubordinated and unsecured obligations of such Guarantor and (save for certain obligations required to be preferred by law) rank equally with all other unsecured obligations of the relevant Guarantor, from time to time outstanding.
B.19	<b>Information about the Guarantors</b>	The Guarantors are Intercommunale Maatschappij voor Gas en Electriciteit van het Westen (Gaselwest) Intercommunale Maatschappij voor Energievoorziening Antwerpen (IMEA), IVERLEK, Intercommunale Maatschappij voor Energievoorziening in West- en Oost-Vlaanderen (IMEWO), SIBELGAS, Intercommunale Vereniging voor de Energiedistributie in de Kempen en het Antwerpse (IVEKA) Intercommunale Maatschappij voor Energieleveringen in Midden-Vlaanderen (INTERGEM) (together the "Guarantors").
B.19/ B.1	<b>Legal and commercial name of the Guarantors</b>	Gaselwest, IMEA, Imewo, Intergem, Iveka, Iverlek and Sibelgas.
B.19/ B.2	<b>Domicile/legal form/ legislation/country of incorporation</b>	<p>The Guarantors are Belgian legal entities.</p> <p>GASELWEST (Intercommunale Maatschappij voor Gas en Elektriciteit van het Westen), a mission entrusted entity ("<i>opdrachthoudende vereniging</i>") incorporated in Belgium and subject to the laws of Belgium. Gaselwest has its registered office at 12 President Kennedypark, 8500 Kortrijk.</p> <p>IMEA (Intercommunale Maatschappij voor Energievoorziening Antwerpen), a mission entrusted entity ("<i>opdrachthoudende</i>")</p>

<b>Section B – Issuer and Guarantors</b>		
		<p><i>vereniging</i>") incorporated in Belgium and subject to the laws of Belgium. IMEA has its registered office at 233 Merksemsesteenweg, 2100 Deurne-Antwerp.</p> <p>IVERLEK, a mission entrusted entity ("<i>opdrachthoudende vereniging</i>") incorporated in Belgium and subject to the laws of Belgium. IVERLEK has its registered office at 58 Aarschotsesteenweg, 3012 Wilsele-Leuven.</p> <p>IMEWO (Intercommunale Maatschappij voor Energievoorziening in West- en Oost-Vlaanderen), a mission entrusted entity ("<i>opdrachthoudende vereniging</i>") incorporated in Belgium and subject to the laws of Belgium. IMEWO has its registered office at 199 Brusselsesteenweg, 9090 Melle.</p> <p>SIBELGAS, a mission entrusted entity ("<i>opdrachthoudende vereniging</i>") incorporated in Belgium and subject to the laws of Belgium. SIBELGAS has its registered office at 12 Sterrenkundelaan, 1210 Sint-Joost-ten-Node (Brussels).</p> <p>IVEKA (Intercommunale Vereniging voor de Energiedistributie in de Kempen en het Antwerpse), a mission entrusted entity ("<i>opdrachthoudende vereniging</i>") incorporated in Belgium and subject to the laws of Belgium. IVEKA has its registered office at 38 Koningin Elisabethlei, 2300 Turnhout.</p> <p>INTERGEM (Intercommunale Maatschappij voor Energieleveringen in Midden-Vlaanderen) a mission entrusted entity ("<i>opdrachthoudende vereniging</i>") incorporated in Belgium and subject to the laws of Belgium. INTERGEM has its registered office at 11 Franz Courtenstraat, 9200 Dendermonde.</p>
B.19/ B.4b	<b>Trend information</b>	Please see B.4b " <i>Trend information</i> " above.
B.19/ B.5	<b>Description of the Eandis Economic Group</b>	<p>Please see B.5 "<i>Description of the Issuer within the group</i>" above.</p> <p>The Guarantors own the low voltage and mid voltage distribution networks for electricity and gas operated by the Issuer, and hold the DSO licences granted by the VREG.</p>
B.19/ B.9	<b>Profit forecast or estimate</b>	Not applicable. The Guarantors do not provide profit forecasts.
B.19/ B.10	<b>Audit report qualifications</b>	Not applicable. There are no qualifications in the audit reports to the Annual Report 2016 and the Annual Report 2015 for the Eandis Economic Group. An emphasis of matter paragraph relating to the regulated nature of the activities of the Eandis Economic Group, and the balances (regulatory receivables) that have arisen as a consequence of the difference between the expected costs of the Eandis Economic Group taken into account in the tariffs, and the costs actually incurred by them (and which balances are still subject in part to approval by the VREG), was added in the audit reports to the Annual reports 2016 and 2015 for the Eandis Economic Group.

**Section B – Issuer and Guarantors**

B.19/ B.12	<b>Selected historical key financial information of the Eandis Economic Group</b>	<p><b>Key Financial Information</b></p> <table border="0" style="width: 100%; border-collapse: collapse;"> <thead> <tr> <th style="width: 60%;"></th> <th style="width: 20%; text-align: center;">As of 31 December 2016</th> <th style="width: 20%; text-align: center;">As of 31 December 2015</th> </tr> </thead> <tbody> <tr> <td colspan="3"><b>Eandis Economic Group (IFRS)</b></td> </tr> <tr> <td colspan="3" style="text-align: center;"><i>in 1000 EUR</i></td> </tr> <tr> <td colspan="3"><b>Statement of Financial Position</b></td> </tr> <tr> <td>Total assets.....</td> <td style="text-align: right;">9,617,821</td> <td style="text-align: right;">9,723,188</td> </tr> <tr> <td>Non-current assets .....</td> <td style="text-align: right;">7,902,818</td> <td style="text-align: right;">7,908,256</td> </tr> <tr> <td>Current assets .....</td> <td style="text-align: right;">1,715,003</td> <td style="text-align: right;">1,814,932</td> </tr> <tr> <td>Equity .....</td> <td style="text-align: right;">2,063,972</td> <td style="text-align: right;">1,977,198</td> </tr> <tr> <td>Non-current liabilities .....</td> <td style="text-align: right;">5,994,950</td> <td style="text-align: right;">6,027,245</td> </tr> <tr> <td>Current liabilities .....</td> <td style="text-align: right;">1,558,899</td> <td style="text-align: right;">1,718,745</td> </tr> <tr> <td colspan="3"><b>Statement of profit or loss (Eandis Economic Group – IFRS)</b></td> </tr> <tr> <td></td> <td style="text-align: center;"><b>Year ended 31 December 2016</b></td> <td style="text-align: center;"><b>Year ended 31 December 2015</b></td> </tr> <tr> <td>Operating revenue.....</td> <td style="text-align: right;">2,788,767</td> <td style="text-align: right;">2,677,762</td> </tr> <tr> <td>Operating expenses .....</td> <td style="text-align: right;">-2,169,960</td> <td style="text-align: right;">-2,065,689</td> </tr> <tr> <td>Profit for the period.....</td> <td style="text-align: right;">282,892</td> <td style="text-align: right;">284,443</td> </tr> <tr> <td colspan="3"><b>Cash flow statement (Eandis Economic Group – IFRS)</b></td> </tr> <tr> <td></td> <td style="text-align: center;"><b>Year ended 31 December 2016</b></td> <td style="text-align: center;"><b>Year ended 31 December 2015</b></td> </tr> <tr> <td>Cash flow from/used in operating activities .....</td> <td style="text-align: right;">709,235</td> <td style="text-align: right;">1,282,610</td> </tr> <tr> <td>Cash flow from/used in investing activities .....</td> <td style="text-align: right;">-351,326</td> <td style="text-align: right;">-431,005</td> </tr> <tr> <td>Cash flow from/used in financing activities .....</td> <td style="text-align: right;">-358,857</td> <td style="text-align: right;">-856,862</td> </tr> <tr> <td>Net change in cash and cash equivalents .....</td> <td style="text-align: right;">-948</td> <td style="text-align: right;">-5,257</td> </tr> </tbody> </table> <p>There has been no significant change in the financial or trading position of the Eandis Economic Group since 31 December 2016 and no material adverse change in the prospects of any of them since 31 December 2016.</p>		As of 31 December 2016	As of 31 December 2015	<b>Eandis Economic Group (IFRS)</b>			<i>in 1000 EUR</i>			<b>Statement of Financial Position</b>			Total assets.....	9,617,821	9,723,188	Non-current assets .....	7,902,818	7,908,256	Current assets .....	1,715,003	1,814,932	Equity .....	2,063,972	1,977,198	Non-current liabilities .....	5,994,950	6,027,245	Current liabilities .....	1,558,899	1,718,745	<b>Statement of profit or loss (Eandis Economic Group – IFRS)</b>				<b>Year ended 31 December 2016</b>	<b>Year ended 31 December 2015</b>	Operating revenue.....	2,788,767	2,677,762	Operating expenses .....	-2,169,960	-2,065,689	Profit for the period.....	282,892	284,443	<b>Cash flow statement (Eandis Economic Group – IFRS)</b>				<b>Year ended 31 December 2016</b>	<b>Year ended 31 December 2015</b>	Cash flow from/used in operating activities .....	709,235	1,282,610	Cash flow from/used in investing activities .....	-351,326	-431,005	Cash flow from/used in financing activities .....	-358,857	-856,862	Net change in cash and cash equivalents .....	-948	-5,257
	As of 31 December 2016	As of 31 December 2015																																																															
<b>Eandis Economic Group (IFRS)</b>																																																																	
<i>in 1000 EUR</i>																																																																	
<b>Statement of Financial Position</b>																																																																	
Total assets.....	9,617,821	9,723,188																																																															
Non-current assets .....	7,902,818	7,908,256																																																															
Current assets .....	1,715,003	1,814,932																																																															
Equity .....	2,063,972	1,977,198																																																															
Non-current liabilities .....	5,994,950	6,027,245																																																															
Current liabilities .....	1,558,899	1,718,745																																																															
<b>Statement of profit or loss (Eandis Economic Group – IFRS)</b>																																																																	
	<b>Year ended 31 December 2016</b>	<b>Year ended 31 December 2015</b>																																																															
Operating revenue.....	2,788,767	2,677,762																																																															
Operating expenses .....	-2,169,960	-2,065,689																																																															
Profit for the period.....	282,892	284,443																																																															
<b>Cash flow statement (Eandis Economic Group – IFRS)</b>																																																																	
	<b>Year ended 31 December 2016</b>	<b>Year ended 31 December 2015</b>																																																															
Cash flow from/used in operating activities .....	709,235	1,282,610																																																															
Cash flow from/used in investing activities .....	-351,326	-431,005																																																															
Cash flow from/used in financing activities .....	-358,857	-856,862																																																															
Net change in cash and cash equivalents .....	-948	-5,257																																																															
B.19/ B.13	<b>Events impacting the Guarantors' solvency</b>	Not applicable. There are no material events particular to the Guarantors which are to a material extent relevant to the Guarantors' solvency.																																																															
B.19/ B.14	<b>Dependence of the Guarantors upon other entities of the Eandis Economic Group</b>	The Guarantors are dependent on the Issuer for the development, management and maintenance of the low voltage and mid voltage distribution networks for electricity as well as low pressure and mid pressure distribution networks for gas owned by them.																																																															
B.19/ B.15	<b>Principal activities of the Guarantors</b>	The object and purpose of the Guarantors is comprised in article 3 of their respective articles of association and comprises of the management and operation of gas and electricity distribution systems. This comprises responsibility for the development of these systems, as well as for their viability and security. The Guarantors also organise public lighting and are responsible for certain social and other public service obligations. The Issuer has been mandated as operating company of the Guarantors. The Guarantors are the owners of the distribution grids, they are the holders of the distribution licence and they invoice customers directly.																																																															
B.19/ B.16	<b>Controlling shareholders</b>	In general, all shares of the Guarantors are held by local authorities (municipalities and in the case of some Guarantors also provinces). No shareholder exercises control (within the meaning of the Belgian Companies Code) over any Guarantor.																																																															

Section B – Issuer and Guarantors		
B.19/ B.17	<b>Solicited credit ratings</b>	Not Applicable.

Section C – Securities		
C.1	<b>Type and class of the Bonds/ISIN</b>	<p><i>Type:</i> The Bonds are 2.000 per cent fixed rate bonds due 23 June 2025 in dematerialised form.</p> <p><i>Identification Code:</i> The Bonds will be uniquely identified by the ISIN Code BE0002285543 and Common Code 162910965.</p>
C.2	<b>Currency</b>	The Bonds will be denominated in euro. Any amount of interest payable in relation to the Bonds will be payable in euro and any amount payable on redemption will be in euro.
C.5	<b>Description of restrictions on the free transferability of the Bonds</b>	Subject to the restrictions in all jurisdictions in relation to offers, sales or transfers, the Bonds are freely transferrable in accordance with the Coordinated Belgian Royal Decree Number 62 of 10 November 1967.
C.8	<b>Description of the rights attached to the Bonds, including ranking and limitations to those rights</b>	<p><i>Status of the Bonds:</i> The Bonds constitute direct, unconditional, unsecured and unsubordinated obligations of the Issuer ranking <i>pari passu</i> with all present and future unsecured and unsubordinated obligations of the Issuer and <i>pari passu</i> among themselves.</p> <p><i>Status of the Guarantees:</i> Claims on the Guarantees on the Bonds constitute direct, unconditional, unsecured and unsubordinated obligations of each of the Guarantors ranking <i>pari passu</i> with all present and future unsecured and unsubordinated obligations of the relevant Guarantor and <i>pari passu</i> among themselves. The obligations of each of the Guarantors are limited to the proportional share such Guarantor holds in the share capital of the Issuer.</p> <p>Gaselwest holds 16.60% of the shares in the Issuer and consequently the Guarantee of Gaselwest is limited to the due and punctual payment of 16.60% of all moneys, obligations and liabilities owed or incurred by the Issuer to the Bondholders in respect of the Bonds, whether actual, future or contingent and whether or not the Bondholder has acquired the Bond on the Issue Date or at a later stage (the "<b>Guaranteed Liabilities</b>").</p> <p>IMEA holds 13.76% of the shares in the Issuer and consequently the Guarantee of IMEA is limited to the due and punctual payment of 13.76% of the Guaranteed Liabilities.</p> <p>Imewo holds 22.42% of the shares in the Issuer and consequently the Guarantee of Imewo is limited to the due and punctual payment of 22.42% of the Guaranteed Liabilities.</p> <p>Intergem holds 10.95% of the shares in the Issuer and consequently the Guarantee of Intergem is limited to the due and punctual payment of 10.95% of the Guaranteed Liabilities.</p> <p>Iveka holds 14.34% of the shares in the Issuer and consequently the Guarantee of Iveka is limited to the due and punctual payment of 14.34% of the Guaranteed Liabilities.</p>



<b>Section C – Securities</b>		
		<p>Iverlek holds 19.43% of the shares in the Issuer and consequently the Guarantee of Iverlek is limited to the due and punctual payment of 19.43% of the Guaranteed Liabilities.</p> <p>Sibelgas holds 2.51% of the shares in the Issuer and consequently the Guarantee of Sibelgas is limited to the due and punctual payment of 2.51% of the Guaranteed Liabilities.</p>
C.9	<b>Interest, maturity and redemption provisions, yield and representative of the Bondholders</b>	<p>Please also refer to Element C.8 above.</p> <p><i>Interest:</i> Each Bond bears interest from and including the Issue Date at the rate of 2.000 per cent per annum.</p> <p><i>Interest Payment Date:</i> 23 June in each year until the Maturity Date, commencing with the first Interest Payment Date falling on 23 June 2018.</p> <p><i>Maturity Date:</i> 23 June 2025.</p> <p><i>Redemption Amount at Maturity Date:</i> 100 per cent of the nominal amount of the Bonds.</p> <p><i>Redemption at the option of the Bondholders following a Change of Control:</i> Each Bondholder will, upon the occurrence of a Change of Control, have the right to require the Issuer to redeem the Bonds it holds on the Change of Control Put Date at the Change of Control Put Redemption Amount.</p> <p>To exercise such right, the relevant Bondholder must, at any time during the Change of Control Put Exercise Period, complete and deliver or deposit with the financial intermediary through which it holds the Bonds (the "<b>Financial Intermediary</b>") for further delivery to the Issuer a duly completed put option notice in the form for the time being obtainable from the Agent (a "<b>Change of Control Put Exercise Notice</b>"). Upon receipt of such Change of Control Put Exercise Notice, the relevant Financial Intermediary shall deliver a duly completed receipt for such Change of Control Put Exercise Notice (a "<b>Put Exercise Receipt</b>") to the depositing Bondholder and provide a copy of the Change of Control Put Exercise Notice to the Issuer.</p> <p>Within fifteen (15) calendar days following a Change of Control, the Issuer shall give notice thereof to the Bondholders in accordance with Condition 13 (<i>Notices</i>) (a "<b>Change of Control Notice</b>").</p> <p>"<b>Change of Control</b>" means a situation where an entity, other than a Public Entity, acquires, directly or indirectly, more than 50% of the shares in the Issuer or more than 50% of the shares in a Guarantor, in each case, save to the extent approved in advance by a resolution of the meeting of the Bondholders.</p> <p>"<b>Public Entity</b>" means any public authority (including any <i>intergemeentelijk samenwerkingsverband/ association intercommunale</i>, but only to the extent such <i>intergemeentelijk samenwerkingsverband/ association intercommunale</i> is controlled (within the meaning of article 5 of the Belgian Companies Code) by municipalities (<i>gemeenten/communes</i>)), or federal, regional or provincial government in Belgium, or any public agency of such</p>

**Section C – Securities**

public authority or federal, regional or provincial governments.

**"Change of Control Put Date"** means the fourteenth (14) Business Day after the expiry of the Change of Control Put Exercise Period.

**"Change of Control Put Exercise Period"** means the period commencing on the date of a Change of Control and ending fifteen (15) calendar days following the Change of Control, or, if later, fifteen (15) calendar days following the date on which a Change of Control Notice is given to Bondholders as required by Condition 5 (b) (iii).

**"Change of Control Put Redemption Amount"** means the amount determined in accordance with the Conditions, which shall be at least equal to the principal amount of the Bonds and accrued interest, and shall represent a maximum yield of 0.75 points above the yield of the Bonds on the Issue Date up to the Maturity Date.

*Events of Default:* The Bonds may be declared immediately due and payable at their principal amount together with accrued interest (if any) at the option of the Bondholders if an Event of Default has occurred and is not remedied prior to notice in writing being given by such Bondholder to the Domiciliary Agent at its specified office. The Events of Default under the Bonds relate to (i) non-payment of the principal, premium or interest on any of the Bonds, (ii) non-performance or non-compliance with any one or more of its other covenants, agreements or undertakings under or in respect of the Bonds, (iii) cross-default under any other present or future indebtedness of the Issuer or any Guarantor, (iv) enforcement of security created or assumed by the Issuer, (v) insolvency of the Issuer, (vi) winding-up or dissolution of the Issuer or any Guarantor, (vii) the Issuer ceasing to be the operating company of the electricity and gas distribution system operators in the designated areas of Flanders, (viii) the Guarantees ceasing to be valid, enforceable or in full force and effect, (ix) authorisations and consents not being taken, fulfilled or done, (x) illegality and (xi) suspension of trading or listing.

*Negative Pledge:* So long as any of the Bonds remains outstanding, neither the Issuer nor any of its subsidiaries nor any Guarantor will create or have outstanding any mortgage, charge, lien, pledge or other security interest upon or with respect to the whole or any part of its present or future business, undertaking, assets or revenues (including any uncalled capital) to secure any present or future indebtedness (whether being principal, premium, interest or other amounts), in the form of or evidenced by notes, bonds, debentures, loan stock, treasury notes, commercial paper, *Namenschuldverschreibung* or other similar debt instruments, whether issued for cash or in whole or in part for a consideration other than cash, and which are, or are capable of being, quoted, listed or ordinarily dealt in or traded on any stock exchange, or in any securities market (including, without limitation, any over the counter market) ("**Relevant Debt**") or to secure any guarantee or indemnity in respect of any Relevant Debt, without at the same time or prior thereto according to the Bonds the same security as is created or subsisting to secure any such Relevant Debt, guarantee or indemnity or such other security as shall be approved by a resolution of the Bondholders.

<b>Section C – Securities</b>		
		<p><i>Yield:</i> Gross actuarial yield: 1.747 per cent (on an annual basis)</p> <p><i>Net yield:</i> 1.153 per cent (on an annual basis)</p> <p>The yield is calculated on the basis of the issue of the Bonds on the Issue Date, the Issue Price, the interest rate of 2.000 per cent per annum and is based on the assumption that the Bonds will be held until 23 June 2025 when they will be repaid at 100 per cent of their nominal amount in accordance with the Conditions. It is not an indication of future yield if the Bonds are not held until their Maturity Date. The net yield reflects a deduction of Belgian withholding tax at the rate of 30 per cent.</p> <p><i>Representative of the holders of the Bonds (the "Bondholders" and each a "Bondholder")/meeting of the Bondholders:</i> No representative of the Bondholders is appointed in relation to the Bonds.</p> <p><i>Governing law:</i> The Bonds and the Guarantees, and any non-contractual obligations arising out of or in connection with the Bonds and the Guarantees, are governed by, and shall be construed in accordance with, Belgian law.</p> <p><i>Jurisdiction:</i> The courts of Brussels, Belgium have exclusive jurisdiction to settle any disputes which may arise out of or in connection with the Bonds and the Guarantees and, accordingly, any legal action or proceedings arising out of or in connection with the Bonds and the Guarantees may be brought in such courts.</p>
C.10	<b>Derivative component in the interest payment</b>	<p>Please also refer to Element C.9 above.</p> <p>Not applicable; there is no derivative component in the interest payment.</p>
C.11	<b>Application for admission to trading</b>	<p>Application has been made to Euronext Brussels for the Bonds to be admitted to trading on the regulated market of Euronext Brussels.</p>

<b>Section D - Risks</b>		
D.2	<b>Key risks regarding the Issuer and the Guarantors</b>	<p>There are certain factors that may affect the Issuer's and the Guarantors' ability to fulfil their obligations under the Bonds. The key risks in respect of the Issuer and the Guarantors include, without limitation, the following:</p>

## Section D - Risks

### **Key risks relating to the Issuer and the Guarantors**

#### ***Risks related to the regulatory framework at the European, federal and regional levels.***

The Guarantors are subject to regulation at the European, Belgian and Flemish level, among others in relation to the tariffs they can charge. The current tariff methodology 2017-2020 for distribution tariffs is based on an ex-ante "revenue cap-oriented" system (*inkomstenregulering*) whereby the cap determines the maximum revenue a DSO can collect from the grid users in a given period, with the exclusion of so-called "exogenous costs" beyond the DSOs' control which are not subject to the revenue cap and are included in the tariffs. Costs other than exogenous costs and that are under the control of the DSOs, are subject to a cap in the tariffs or are entirely for the account of the DSOs (the latter includes e.g. penalties). The Guarantors may suffer losses if such endogenous or other costs are not covered by the profit margin of the DSOs. Tariff decisions by the regulator and changes to the tariff parameters can all affect the activities, financial condition and results of the Issuer and the Guarantors. It should be emphasised that future changes to the tariff methodology, which is currently established for the regulatory period 2017-2020, for tariff periods after 2020 might negatively impact the Issuer's and the Guarantors' business and performance.

#### ***Risk of an inefficient green power certificates market***

The market for green power certificates in the Flemish Region has been inefficient for a number of years. This has resulted in expenses for the Guarantors that can only be recovered at a later time. Yet, reforms of the green power certificate mechanism should in principle rebalance the market for green power certificates and alleviate the operational and financial pressure of the purchase obligation on the DSOs.

#### ***Early termination of the Guarantors' licence of DSO and termination of the appointment of the Issuer as operating company of the Guarantors***

The Guarantors are appointed as DSOs by the relevant regulator for a fixed duration. If the appointment is terminated before the expiry of their appointment or is not renewed, there may be material, negative consequences on the financial position of the relevant entity. Although unlikely, if some or all of the Guarantors would terminate the appointment of the Issuer as their operating company, this would endanger the viability of Eandis System Operator and its ability to repay the principal and interest on the Bonds.

#### ***Immunity of execution***

The Guarantors are public law entities, and cannot be declared bankrupt. Also, they benefit from an immunity of execution (not to be considered as an immunity of jurisdiction). The distribution networks owned by the Guarantors can consequently not be seized by the Bondholders. Property, plant and equipment (which includes the value of the distribution grid infrastructure) amounted to EUR 7,804.1 million on a total asset base of EUR 9,617.8 million as at 31 December 2016 for the Eandis Economic Group.

## Section D - Risks

### ***Risks Related to the limited duration of the Guarantors***

The Guarantors have the form of a mission entrusted entity and are established for a (renewable) definite term of 18 years, ending on 9 November 2019. If the participating shareholders of a Guarantor do not renew the duration of the mission entrusted entity, such Guarantor will be put into liquidation. Even if the term is renewed, certain shareholders may exit the Guarantors at the end of the term (or, in a limited number of cases, before the end of the term). While management of the Issuer and the Guarantors believes that the net effect of such decisions in 2019 will most likely not be significant and that other changes to the duration and/or shareholding structure of the Guarantors will not occur in a manner that is significant for the Bondholders, it cannot be excluded that the Issuer's and the targeted Guarantors' activities, profits and financial situation will be adversely affected.

### ***Financial Risks of the Business***

#### *Risks associated with financial debt outstanding*

The Issuer and the Guarantors have financial debt outstanding that could adversely affect their business. As at 31 December 2016, Eandis Economic Group's total long-term debt amounted to EUR 5,244.4 million. In this amount, bonds represent an amount of EUR 3,397.2 million and bank loans represent EUR 2,202.6 million (current portion of long-term debt included in the amounts mentioned). Short-term debt at 31 December 2016 amounted to EUR 766.7 million, of which EUR 411.3 million short-term debt and EUR 355.4 million the current portion of long-term debt. The Eandis Economic Group's total of equity and liabilities as at 31 December 2016 was EUR 9,617.8 million.

The total external indebtedness of the Issuer amounts to EUR 3,808 million, of which 3,247 million long-term indebtedness. As at 31 December 2016, the ratio of long-term and short-term interest bearing loans and borrowings as a percentage of total assets of the Issuer was 88%. The same ratio for the Eandis Economic Group as at 31 December 2016 was 63%.

All long-term indebtedness of the Issuer is guaranteed by each of the Guarantors in proportion to their participation in the share capital of the Issuer as at the date of the entry into the financing arrangements. The Issuer's and the Guarantors' access to sources of financing to cover their financing needs or repayment of their debt could be impaired by the deterioration of financial markets, and the Issuer and the Guarantors may be unable to access the funds that they need when it comes to refinance their debt. The Issuer and the Guarantors may borrow additional funds to support their capital expenditures and working capital needs and to finance future acquisitions. The ability of the Issuer and the Guarantors to pay principal and interest on the Bonds and on their other debt depends primarily on the regulated tariffs they are and will be entitled to charge.

#### *The Issuer is dependent on the cash flow generated by the Guarantors*

The proceeds of financing attracted by the Issuer are on-lent by the Issuer to the Guarantors at cost. Any obligation of the Issuer towards

## Section D - Risks

the providers of such financing is hence covered by a receivable on the Guarantors. Outside raising monies in the capital markets with the guarantee of the Guarantors, the Issuer does not generate any profit itself, as all its expenses are invoiced at cost to the Guarantors. The Guarantors are the owners of the network, and invoice the energy suppliers for the use of the network. Therefore, and outside refinancing attracted by the Issuer, the Issuer is dependent on the cash flow generated by the Guarantors, and used for the repayment of, or payment of interest on, the loans granted by the Issuer to such Guarantor to service its debt. The ability of the Guarantors to generate cash flow primarily depends on the regulatory framework and the regulated tariffs.

### *Risk related to pension liabilities*

The Issuer has granted its (former) employees a range of pensions and other post-employment benefit plans, both of the defined contribution type as well as of the defined benefit type. For the defined contribution plans, the Issuer is faced with the investment risk to be able to continue to cover the level of guaranteed interest rates. For the defined benefit plans, the Issuer is confronted with the investment risk related to the beneficiaries' entitlement to the contractual lump sum to be paid out to them on their retirement. As of 31 December 2016, the total defined benefit obligation and long-term employee benefits (a range of pensions and other post-employment benefit plans) amounts to EUR 931 million. The fair value of the plan assets amounts to EUR 672 million. Consequently, as at 31 December 2016, the difference between the obligations and the assets amounts to EUR 259 million.

### *Risk related to the use of derivative financial instruments*

The Eandis Economic Group has entered into a number of interest rate swaps in order to convert variable interest rates on long term loans into fixed interest rates. The fair value of these derivative financial instruments is EUR 131 million, and constitutes a payable in the accounts of the Eandis Economic Group.

### *Operational Risks of the Business*

Eandis System Operator may be held liable in case of security of supply issues, distribution system disruptions or system breakdowns, and operates facilities that may cause significant harm to its personnel or third parties.

A failure of IT systems and processes used by the Issuer (including defects in its databases) constitutes a considerable risk, as its IT system is essential for the safe and reliable operation of the distribution networks it operates.

Eandis System Operator may incur significant costs to comply with environmental and city planning laws.

<b>Section D - Risks</b>		
		Eandis System Operator may incur significant losses if it cannot succeed in attracting and retaining enough qualified and competent personnel.
D.3	<b>Key risks regarding the Bonds</b>	<p>There are certain key risk factors which are material for the purpose of assessing the risks associated with the Bonds, including, without limitation, the following key risk factors:</p> <p>(i) <i>the Bonds may not be a suitable investment for all investors:</i> each potential investor in the Bonds must determine the suitability of that investment in light of its own circumstances and each potential investor should have sufficient knowledge and experience, appropriate analytical tools to make a meaningful evaluation of the Bonds, evaluate the impact of the Bonds on its overall investment portfolio, and should have sufficient financial resources and liquidity to bear all of the risks of an investment in the Bonds;</p> <p>(ii) <i>the Bonds and the Guarantees are unsecured obligations of the Issuer and the Guarantors and there is no limitation on issuing further debt:</i> The Bonds do not limit the ability of the Issuer or the Guarantor to incur indebtedness or issue securities, or grant security for such indebtedness. All indebtedness of the Issuer is currently unsecured, and the negative pledge condition protects Bondholders against the Issuer or the Guarantors granting security for other Relevant Debt (essentially other capital markets debt (as opposed to bank loans)) as set out in the Conditions (or please see in respect of the negative pledge Element C.9 above). It cannot be excluded that the Issuer or the Guarantors would enter into secured indebtedness in the future, which will then be repaid first with the proceeds from the enforcement of such security in the event of liquidation, dissolution, reorganisation, bankruptcy or similar procedure affecting the Issuer or the Guarantors;</p> <p>(iii) <i>the payments in respect of the Bonds are guaranteed on a several but not joint basis, subject to pro rata limitations:</i> the obligations of each Guarantor under its respective Guarantee are on a several but not joint basis, meaning that each Bondholder will need to make a claim against each of the seven Guarantors, each claim for a portion of the total claim of such Bondholder against the Issuer. If any of the Guarantors would become insolvent, an investor would not benefit from a guarantee for the full amount of the obligations of the Issuer in respect of the Bonds;</p> <p>(iv) <i>there may not be an active trading market for the Bonds:</i> the Bonds will be new securities and may not be widely distributed. Although the Bonds are listed, it may be that no active trading market for the Bonds will develop;</p> <p>(v) <i>the Conditions may be modified and defaults may be waived by the defined majorities of the meetings of Bondholders:</i> the Bondholders may modify the Conditions and may waive defaults by the defined majorities of the meetings of Bondholders that bind all Bondholders, including Bondholders who did not attend and vote at the relevant meeting and Bondholders who voted in a manner contrary to</p>

**Section D - Risks**

		<p>the majority;</p> <p>(vi) <i>the Issuer and the Guarantors may not be able to repay the Bonds:</i> the ability of the Issuer and the Guarantors to repay the Bonds will depend on their respective financial condition at the relevant time, and may be limited by law, by the terms of its indebtedness and by the agreements that they may have entered into on or before such date, which may replace, supplement or amend its existing or future indebtedness;</p> <p>(vii) <i>there may be an impact of fees, commissions and/or inducements on the issue price and/or the offer price:</i> investors should note that the issue price and/or the offer price of the Bonds may include certain additional fees and costs, in particular, in relation to any actual or potential investor in the Bonds that is not a Qualified Investor (the "<b>Retail Investors</b>"), a selling and distribution fee of 1.875 per cent. (the "<b>Retail Fee</b>") and, in relation to <i>gekwalificeerde beleggers/investisseurs qualifiés</i> within the meaning of Article 10 of the Prospectus Law, of Directive 2004/39/EC or of the applicable laws of any relevant jurisdiction within the European Economic Area (the "<b>Qualified Investors</b>"), a fee equal to or lower than such Retail Fee as may be determined by the Joint Lead Managers;</p> <p>(viii) <i>Change of control put:</i> the Bondholders may request the Issuer to redeem the Bonds prior to maturity in the event of a Change of Control. If holders of a significant proportion of the Bonds exercise the put option, Bonds in respect of which the Change of Control Put is not exercised may be illiquid and difficult to trade. In addition, the Change of Control put can only be exercised in specified circumstances of a "Change of Control" as defined in the Conditions, which may not cover all situations where a change of control may occur or where successive changes of control occur in relation to the Issuer and any of the Guarantors.</p> <p>(ix) <i>the Bonds may be redeemed prior to their maturity:</i> in the event of the occurrence of an Event of Default the Bonds may be redeemed prior to their maturity; in such event, and provided the Issuer and/or the Guarantors are able to repay the amounts due, investors may not be able to reinvest the amounts at the same conditions.</p> <p>(x) <i>the market value of the Bonds may be affected by certain factors:</i> the market value of the Bonds may be affected by the creditworthiness of the Issuer and the Guarantors and a number of additional factors;</p> <p>(xi) <i>the payments under the Bonds may be subject to withholding tax:</i> potential purchasers and sellers of the Bonds should be aware that they may be required to pay taxes or other documentary charges or duties in accordance with the laws and practices of the country where the Bonds are transferred or other jurisdictions;</p> <p>(xii) <i>the Conditions may be affected by a change in the law and practices:</i> no assurance can be given as to the impact of any</p>
--	--	--



<b>Section D - Risks</b>		
		<p>possible judicial decision or change to the laws of Belgium, the official application, interpretation or the administrative practice after the date of this Prospectus;</p> <p>(xiii) <i>the Bonds may be affected by changes in market interest rates</i>: an investment in the Bonds involves the risk that subsequent changes in market interest rates may adversely affect the value of the Bonds; and</p> <p>(xiv) <i>the Joint Lead Managers may engage in transactions adversely affecting the interests of the Bondholders</i>: potential investors should be aware that the Issuer or any of its subsidiaries and the Guarantors, within the context of a specific transaction or a general business relationship with the Agent and/or each of the Joint Lead Managers, <i>inter alia</i>, has entered into debt financings, and the conditions of such debt financings may be or are more restrictive than the Conditions of the Bonds. Within such context, the Agent and the Joint Lead Managers have no fiduciary duties or other duty of any nature whatsoever <i>vis-à-vis</i> the Bondholders and they are under no obligation to take into account the interests of the Bondholders.</p>

<b>Section E - Offer</b>		
E.2b	<b>Reasons for the offer and use of proceeds</b>	<p>The net proceeds of the Bonds will be used primarily for the refinancing of the 2010-2017 4.00 per cent bond (EUR 150 million) which matures on 23 June 2017. If the aggregate amount for which Bonds are issued exceeds EUR 150 million, such amount will be used by the Issuer to on-lend to the Guarantors to finance recurrent investments for grid maintenance and grid expansion provided for in the investment plan of the Eandis Economic Group (which was approved by the VREG). The specific projects that will be financed through such proceeds have not yet been determined.</p> <p>The net proceeds of the issue are expected to amount to EUR 149,795,000 (expensed deducted) (in case the aggregate amount for which Bonds are issued is EUR 150,000,000) or EUR 199,795,000 (expensed deducted) (in case the aggregate amount for which Bonds are issued is EUR 200,000,000).</p>
E.3	<b>Terms and conditions of the offer</b>	<p><i>Issue Date</i>: 23 June 2017 (the "<b>Issue Date</b>").</p> <p><i>Issue Price</i>: 101.875 per cent</p> <p><i>Denomination</i>: The Bonds are issued in principal amounts of EUR 500.</p> <p><i>Offer period</i>: from 9 June 2017 until 16 June 2017 included (subject to early closing). The Subscription Period may be closed by the Issuer in certain circumstances set out in the Prospectus, including, as from the end of the Minimum Subscription Period, at any time if the total amount of the Bonds reaches EUR 150,000,000.</p> <p><i>Joint Lead Managers</i>: Belfius Bank NV/SA and BNP Paribas Fortis NV/SA.</p>

## Section E - Offer

*Agent:* Belfius Bank NV/SA.

*Public Offer Jurisdiction:* Belgium.

*Conditions to which the Public Offer is subject:* The Public Offer and the issue of the Bonds is subject to a limited number of conditions set out in the placement agreement entered into between the Issuer, the Guarantors and the Joint Lead Managers (the "**Placement Agreement**") and which include, amongst others: (i) the correctness of the representations and warranties made by the Issuer and the Guarantors in the Placement Agreement, (ii) the Placement Agreement, the Clearing Services Agreement and the Agency Agreement having been executed by all parties thereto prior to the Issue Date, (iii) the admission to trading of the Bonds on the regulated market of Euronext Brussels being granted on or prior to the Issue Date, (iv) there having been, as at the Issue Date, no Material Adverse Change (as defined in the Placement Agreement) affecting the Issuer; its Subsidiaries and the Guarantors and no event making any of the representations and warranties contained in the Placement Agreement untrue or incorrect on the Issue Date as if they had been given and made on such date and the Issuer and the Guarantors having performed all the obligations to be performed by it under the Placement Agreement on or before the Issue Date, and (v) at the latest on the Issue Date, the Joint Lead Managers having received customary confirmations as to certain legal and financial matters pertaining to the Issuer and the Guarantors. These conditions can be waived (in whole or in part) by each of the Joint Lead Managers. If the terms of the Public Offer and the subsequent issuance of the Bonds are not met on the Issue Date (subject to waiver by the Joint Lead Managers of the conditions that could not be fulfilled) or any Joint Lead Manager terminates the Placement Agreement in one of the circumstances mentioned above, the Bonds will not be issued. Termination of the Placement Agreement by one of the Joint Lead Managers does not trigger the termination of the Placement Agreement for the other Joint Lead Managers, but there is no obligation for the non-terminating Joint Lead Managers to place the Bonds assigned to the terminating Joint Lead Manager.

*Allocation:* Each Joint Lead Manager has the right to place 40% (*ie* together 80%) of the aggregate nominal amount of the Bonds exclusively with its own retail and private banking clients who are Retail Investors with the remaining 20% being placed with Qualified Investors. All subscriptions that have been validly introduced by the Retail Investors with the Joint Lead Managers before the end of the Minimum Subscription Period will be taken into account when the Bonds are allotted, it being understood that in case of oversubscription a reduction may apply, *i.e.*, the subscriptions will be scaled back proportionally by each Joint Lead Manager, with an allocation of a multiple of EUR 500 which corresponds to the nominal value of the Bonds. Depending on the Joint Lead Manager with whom a subscription is made, a different re-assignment percentage may be applied. Bonds that are not placed with Retail Investors at the end of the Minimum Subscription Period, may in certain circumstances be reallocated to Qualified Investors. The portion of the Bonds assigned to be placed with Qualified Investors shall be allocated thereby giving priority to Qualified Investors for onward placement to Retail Investors. This privileged allocation may cause certain Qualified Investors to receive less than or none of the

<b>Section E - Offer</b>		
		<p>ordered Bonds.</p> <p><b>"Minimum Subscription Period"</b> means the first day of the Subscription Period until 5.30 p.m. (Brussels time).</p>
E.4	<b>Interest of natural and legal persons involved in the issue/offer</b>	<p>Investors should be aware that the Issuer and the Guarantors are involved in a general business relationship or/and in specific transactions with the Joint Lead Managers and that they might have conflicts of interests which could have an adverse effect to the interests of the Bondholders. As at the date of the Prospectus, the Joint Lead Managers provide, among others, payment services, investments of liquidities, credit facilities, bank guarantees and assistance in relation to bonds and structured products to the Eandis Economic Group for which certain fees are being paid to the Joint Lead Managers by the Eandis Economic Group. As at 31 December 2016, the existing financial indebtedness of the Eandis Economic Group outstanding towards Belfius Bank SA/NV amounts to EUR 712 million and towards BNP Paribas Fortis SA/NV amounts to EUR 579 million. Potential investors should also be aware that the Joint Lead Managers may hold from time to time debt securities, shares or/and other financial instruments of the Issuer or the Guarantors.</p> <p>Within the framework of the normal business relationship with its banks, the Issuer, the Guarantors or another company within the Eandis Economic Group has entered into loans and other facilities with the Joint Lead Managers or the Agent (or some of its affiliates) (via bilateral transactions or/and syndicated loans together with other banks). The terms and conditions of these debt financings may be or are more restrictive than the terms and conditions of the proposed Bonds.</p> <p>When acting in the capacity of lenders, the Joint Lead Managers and the Agent have no fiduciary duties or other duties of any nature whatsoever <i>vis-à-vis</i> the Bondholders and are under no obligation to take into account the interests of the Bondholders.</p>
E.7	<b>Estimated expenses charged to the investor by the Issuer</b>	<p>Retail investors will bear a selling and distribution commission of 1.875 per cent (the "<b>Retail Fee</b>") included in the Issue Price.</p> <p>The financial services in relation to the Bonds will be provided free of charge by the Joint Lead Managers. The costs for the custody fee for the Bonds are charged to the subscribers. Investors must inform themselves about the costs their financial institutions might charge them.</p> <p>Qualified investors will bear a distribution commission of 1.875 per cent subject to the discount based, amongst others, on (i) the evolution of the credit quality of the Issuer (credit spread), (ii) the evolution of the interest rates, (iii) the success (or lack of success) of the placement of the Bonds, (iv) the amount of Bonds purchased by an investor and (v) the priority given to Qualified Investors acting as intermediaries for onward placement towards Retail Investors, each as determined by each Joint Lead Manager in its sole discretion. The discount on the distribution commission paid by the qualified investors will range between 0.50% and 0.75% per cent (the "<b>QI Fee</b>").</p>

## PART II – RISK FACTORS

*The Issuer and the Guarantors believe that the following factors may affect the Issuer's and the Guarantors' ability to fulfil their respective obligations under the Bonds. All of these factors are contingencies which may or may not occur and neither the Issuer nor the Guarantors are in a position to express a view on the likelihood of any such contingency occurring. The sequence in which the following risk factors are listed is not an indication of their likelihood to occur or of the extent of their commercial consequences.*

*In addition, factors which are material for the purpose of assessing the market risks associated with the Bonds are also described below.*

*Prospective investors should note that the risks relating to the Issuer and the Guarantors, the industry in which they operate and the Bonds summarised in "Part I – Summary of this Prospectus" are the risks that the Issuer and the Guarantors believe to be the most essential to an assessment by a prospective investor of whether to consider an investment in the Bonds. However, as the risks which the Issuer and the Guarantors face relate to events and depend on circumstances that may or may not occur in the future, prospective investors should consider not only the information on the key risks summarised in "Part I – Summary of this Prospectus" but also, among other things, the risks and uncertainties described below.*

*The Issuer and the Guarantors believe that the factors described below represent the principal risks inherent in investing in the Bonds, but the inability of the Issuer or the Guarantors to pay interest, principal or other amounts on or in connection with the Bonds may occur for other reasons which may not be considered significant risks by the Issuer or the Guarantors based on information currently available to them or which they may not currently be able to anticipate. Prospective investors should also read the detailed information set out elsewhere in this Prospectus, including any documents incorporated by reference, and reach their own views prior to making any investment decision and consult with their own professional advisors if they consider it necessary.*

*Terms defined in "Part IV – Terms and conditions of the Bonds" shall have the same meaning where used below.*

*Due to the particular structure of the economic group comprising of the Issuer, its Subsidiaries (as defined in the Conditions) and the Guarantors, all risk factors set out below relate to this economic group as a whole and not just to the Issuer.*

### **Factors that may affect the Issuer's and the Guarantors' ability to fulfil their obligations under or in connection with the Bonds**

#### ***Risks Related to the Regulatory Framework at the European, Federal and Regional Levels***

The Issuer's and the Guarantors' revenues, and the conduct of their activities, are dependent on the actions and decisions of law-making and regulatory bodies in Flanders, Belgium and Europe. The related risks mainly include the following:

*The regulatory framework is evolving, which may affect the Issuer's and Guarantors' operational and financial performance.*

The Guarantors and the Issuer are subject to extensive regulation at different levels, European, Belgian and Flemish. The regulatory framework was first put into place in the mid-nineties to implement the First European Energy Directives<sup>3</sup>. In the following years, the framework went through an evolutionary process that focused on strengthening the liberalised energy market with the Second European Energy Directives<sup>4</sup>. The Second European Energy Directives required as of 1 July 2007 the legal and functional separation of the distribution activities from other activities not relating to distribution. The "Third

<sup>3</sup> With regard to the electricity market it concerns Directive 96/92/EC of 19 December 1996, OJ L 27, 30.1.1997, p. 20–29 (the "First Electricity Directive"); for the gas market, it concerns Directive 98/30/EC of 22 June 1996, OJ L 204, 21.7.1998, p. 1–12 (the "First Gas Directive").

<sup>4</sup> With regard to the electricity market it concerns Directive 2003/54/EC of 26 June 2003, OJ L 176, 15.7.2003, p. 37–56 (the "Second Electricity Directive"); for the gas market, it concerns Directive 2003/55/EC of 26 June 2003, OJ L 176, 15.7.2003, p. 57–78 (the "Second Gas Directive").

**Energy Package**<sup>5</sup> published in 2009 continued and reinforced this trend, and granted greater autonomy to the regulator to fix or approve the tariffs. In addition, at the end of 2016 the European Commission launched a major package of legislative reforms aimed at progressing its plans for an Energy Union including a recast of the Third Electricity Directive and the Electricity Regulation<sup>6</sup> (the "**Winter Package**")<sup>7</sup>. These legislative proposals do not fundamentally alter the tariff-setting competences of regulators in the DSO and TSO sector. The Winter Package's proposals need to follow the traditional legislative procedure before becoming binding European legislation and this is expected at the earliest in the second half of 2018.

The tariff framework in Belgium and the Flemish Region has been modified and extended on several occasions and might further evolve in the future. Since 1 July 2014, the Flemish Region has the competence to set distribution grid tariffs; the Flemish regulator VREG has the competence to establish the tariff methodology on the basis of the tariff guidelines in article 4.1.32 of the Flemish Decree of 8 May 2009 (as amended from time to time) (the "**Energy Decree**"). The Energy Decree specifies that the tariff framework should ensure tariff stability and legal security and should allow the DSOs to make the necessary investments in their grid.

Even if the Issuer and the Guarantors proactively try to anticipate new regulatory schemes, modifications of the regulatory framework governing the DSOs may always cause uncertainty and can affect the activities, financial condition and results of the Issuer and the Guarantors.

*Tariff decisions by the competent regulator may negatively affect the Guarantors' results of operations*

As further explained in section 3.1 in "*Part VIII - Regulatory Framework applicable to the Flemish DSOs*", the distribution grid fees applied by the DSOs are generated by the tariffs set pursuant to specific regulations. This entails that the distribution grid fees are (i) based on a tariff methodology established by the regulator and (ii) have to be submitted for prior approval to the regulator. The regulator will exercise a control on the proposed distribution grid fees. This will be done in advance ("ex ante") when the DSOs' tariff proposals are submitted for approval. At the time of approval the regulator can reject elements of the budgeted costs and the regulator will establish the allowable income for a DSO. Once the fees have been approved, the DSO merely has an "ex post" ("ex post"), reporting obligation and is obliged to submit a detailed report to the regulator regarding the actual costs incurred during the previous year.

The current tariff methodology 2017-2020 for distribution tariffs is based on an ex-ante "**revenue cap-oriented**" system (*inkomstenregulering*) whereby a cap determines the maximum revenue a DSO can collect from the grid users in a given period (the "**allowable income**"), with the exclusion of so-called "exogenous costs" beyond the DSOs' control. In addition, the current tariff methodology caters for an adequate compensation for a DSO's volume risk (i.e. the risk that the actual income derived from the grid fees deviated from the expected income due to a difference between actual and expected off take from the grid users). Whilst such an "ex ante" revenue cap can be beneficial for a DSO if its actual "endogenous" costs (i.e. costs subject to revenue cap) are lower than its initially set allowable income, this regulatory scheme can also lead to a situation where its "endogenous" costs are higher than the predetermined allowable income (in which case the relevant DSO may not be able to recover these amounts through the distribution tariffs).

The current revenue cap model allows for the allowed revenues to be updated annually to reflect inflation as measured by the retail price index. The tariff methodology 2017-2020 further uses a so-called X-factor to benchmark a DSO's efficiency and a "Q" factor measuring the level of quality of a DSO's services. Both the X- and Q-factor have not yet been implemented in the 2017-2020 tariff methodology. They are

---

<sup>5</sup> With regard to the electricity market it concerns Directive 2009/72/EC of 13 July 2009, *OJ L 211*, 14.8.2009, p. 55–93 (the "**Third Electricity Directive**"); for the gas market, it concerns Directive 2009/73/EC of 13 July 2009, *OJ L 211*, 14.8.2009, p. 36–54 (the "**Third Gas Directive**").

<sup>6</sup> Regulation (EC) No. 714/2009 of the European Parliament and the Council of 13 July 2009 on conditions for access to the network for cross-border exchanges in electricity and repealing Regulation (EC) No 1228/2003

<sup>7</sup> See the proposal of the European Commission <http://ec.europa.eu/energy/en/news/commission-proposes-new-rules-consumer-centred-clean-energy-transition>.

expected to be implemented as from the 2021-2024 tariff methodology. In the period 2017-2020 the DSOs have to collect the data needed for such an implementation.

Tariff decisions by the regulator and changes to the tariff parameters can all affect the activities, financial condition and results of the Issuer and the Guarantors. Although it remains unclear which tariffs will be applied for the period beyond 2020, the Issuer and the Guarantors nevertheless expect that these tariffs will respect the principles outlined in the Third Energy Package and consequently allow the necessary investments in order to ensure the long-term viability of the distribution grid.

#### *Incentive mechanism for the Guarantors to operate more efficiently*

Since 1 July 2014, the VREG is competent to implement the incentive regulation from 2015 onwards. The VREG may apply benchmarking exercises and incentive regulation to a greater number of categories of costs compared to the period before July 2014 (as already indicated in its Advice of 26 June 2014 and its tariff methodology for the regulatory period 2017-2020). In addition, the VREG has openly questioned certain guidelines in the Energy Decree in relation to incentive regulation as these guidelines may hinder its benchmarking exercises. Although these recommendations of the VREG may influence the future regulatory framework in the Flemish Region, it should be emphasised that it is the Flemish legislator who has the power to decide on the Flemish general principles in relation to the distribution grid fees (provided this does not excessively affect the tariff setting competences of the VREG), and thus the extent to which the current guidelines will be maintained.

Consequently, the VREG will be required to take existing legislation into account. Nevertheless, it is still possible that the Guarantors are not able to pass on all of their costs in their distribution tariffs.

#### *Risk of an inefficient green power certificates market*

The system of so-called renewable energy certificates ("RECs") as further described in section 6.10 in "*Part IX - Description of the Issuer and the Guarantors*" provides that the DSOs have an obligation to buy renewable energy certificates at a predetermined price upon request of a green energy producer. Subsequently, the DSOs must offload these renewable energy certificates in the market while booking the difference between the guaranteed price and the market price for the certificates as a public service obligation cost, to be charged through the distribution grid fee. However, this market for renewable energy certificates has for a long time been inefficient. There were too many green energy producers and a decreasing demand to buy renewable energy certificates led to a downward pressure on the prices of certificates. This has resulted in accumulated financial expenses for the DSOs which can only be recovered (wholly or partly) by the DSOs at a later date (i.e. in the next tariff period). However, the reform of the renewable energy certificate mechanism should in principle rebalance the market for renewable energy certificates and alleviate the pressure of the purchase obligation on the DSOs. As explained in more detail in section 6.10 in "*Part IX - Description of the Issuer and the Guarantors*", the Flemish banking regime introduced in 2014 obliging the Flemish DSOs to temporarily immobilise ("bank") RECs in order to moderate the market price of these certificates, might still considerably impact the DSOs' operations. The increase of the quota to be met by the non-green energy producers has stimulated the demand for certificates being offered for sale by the Guarantors. In 2016 the Guarantors have been able to sell certificates (both green energy and cogeneration certificates) for a total amount of EUR 219,116,364.00, of which 219,115,864.00 green energy certificates and EUR 500.00 cogeneration certificates; Additionally, each individual Guarantor has been able to sell in December 2016 up to EUR 15 million outstanding renewable energy certificates in the so-called DAEB<sup>8</sup> fund mechanism. Out of this fund financed by the contributions raised by the Flemish Energy Contribution, the Flemish Energy Agency was able to purchase additional certificates (RECs) for an amount of EUR 15 million EUR per individual DSO/Guarantor in December 2016. The measure taken by the Flemish government to introduce an additional tax has also somewhat alleviated the financial pressure on the Guarantors due to the certificates.

#### *Limited statutory duration of DSOs until 2019*

The Guarantors are mission entrusted entities governed by the Flemish Decree on Intermunicipal Cooperation of 6 July 2001 (as amended), and have a limited duration of maximum 18 years. Shareholders can only voluntarily exit at the end of the 18 year period when a decision is made on a

<sup>8</sup> DAEB: Dienst van Algemeen Economisch Belang (Service of General Economic Interest)

possible renewal and not throughout the fixed 18 year lifetime. The Guarantors' current duration takes an end on 9 November 2019. Their duration can only be renewed on 9 November 2019 with a 75% majority of the votes cast by the participating municipalities as well as a majority (*i.e.* 50% plus one) of the number of participating municipalities. In the more likely scenario that all Guarantors' duration will be renewed, municipalities that have voted against the decision to extend will have the opportunity to exit the relevant Guarantor at the end of the year in which the decision to renew was made. In the less likely scenario that a Guarantor's duration would not be renewed, such Guarantor will be placed in liquidation procedures. In such case an extraordinary general assembly of shareholders of the Guarantor shall appoint liquidators in the same way as it appoints directors. Such liquidators will act together in a collegial body of liquidators to manage and prepare the liquidation. In addition to the aforementioned, the shareholders of the respective Guarantors may liquidate a Guarantor at any time by vote of a special majority described in the articles of association of the respective Guarantors.

Upon completion of the liquidation procedure, the remaining assets will be transferred back to the participating municipalities and the liquidation will be closed. Installations, materials, or stock owned or used by the Guarantor will, against a compensation determined by a college of experts, be transferred back to the participating municipality on whose territory they are located, while profits and reserves will be distributed to the participating municipalities pro rata their share in the Guarantor. Personnel are also to be taken over by the participating municipality on whose territory such personnel operates, in accordance with modalities to be fixed by a college of experts. In theory, after completion of the liquidation of a Guarantor, Bondholders would no longer have the benefit of the guarantee granted by such Guarantor. However, given that the Guarantors are owner of the grid assets and due to these grid assets being required to operate the supply of electricity and gas to end consumers, the expectation is that any full liquidation of a Guarantor would involve the transfer through a permitted reorganisation of the relevant grid assets to another entity, which – in accordance with the terms of the guarantee – assumes the obligations of the Guarantor so liquidated.

It cannot be excluded that some of the shareholders in the Guarantors might vote against a decision to extend and might therefore leave a Guarantor to set up their own DSO or to join an Infrac DSO and that the relevant Guarantor would no longer operate on these municipalities' territory. However, the share that any such resigning municipality would obtain upon its resignation in any Guarantor will be calculated by reference to the net assets of the relevant Guarantor. Given the fact that the proceeds of the Bonds will be on-lent by the Issuer to the Guarantors, the net assets of each of the Guarantors will reflect its pro rata share in the Bonds.

Conversely, it cannot be excluded that certain municipalities of the Infrac DSOs, which also have a termination date on 9 November 2019, might at the same time choose to join a Guarantor.

While management of the Issuer and the Guarantors believes that the net effect of these decisions in 2019 will most likely not be significant, and that other changes to the duration and/or shareholding structure of the Guarantors will not occur in a manner that is significant for the Bondholders, it cannot be excluded that the Issuer's and the targeted Guarantors' activities, profits and financial situation will be adversely affected by any such changes, as the revenue of the Guarantors depend on the number of EAN-codes managed by it (and therefore on the municipalities that are its shareholders). Where any such changes affect the number of EAN-codes managed by the Issuer by more than 10% compared to those managed on the date of this Prospectus, and save in the context of a permitted reorganisation involving a Permitted Successor Entity (as defined in the Conditions), an Event of Default will occur.

*Early termination of the Issuer's status as operating company and the Guarantors' appointment of DSO, non-commercial nature of the Guarantors*

The Guarantors were re-appointed as DSOs on 3 February 2015 (for electricity) and on 29 September 2015 (for gas, except for IMEA that was appointed on 17 December 2008) by decision of the VREG, the Flemish energy regulator, for a period of 12 years.

These appointments are subject to early termination by the VREG under certain circumstances including:

- bankruptcy, winding-up, merger or demerger of the DSO;
- serious breach of the DSOs' obligations; or

- significant changes in the shareholder structure of the respective DSOs or the Issuer that could jeopardise the independent management of a distribution network.

Eandis System Operator was recognised as the Guarantors' operating company (*werkmaatschappij*) by decision of the VREG dated 24 February 2015 for a maximum period equal to the duration of the appointment of the Guarantors as a DSO for electricity. The VREG decision of 24 February 2015 also applies for the gas distribution activity, as confirmed in a letter by the VREG dated 1 October 2015.

Whilst the Energy Decree does not explicitly provide for this, one cannot rule out the risk that the VREG decides to withdraw this recognition, if the operating company seriously breaches its legal duties.

If the appointment of a Guarantor as a DSO, or the recognition of Eandis System Operator as operating company, is terminated before the expiry of the appointment or is not renewed upon termination of the appointment, there may be material, negative consequences on the Issuer's and the targeted Guarantors' activities, profits and financial situation.

Due to their non-commercial nature, the Guarantors are not considered merchants by the Flemish Decree of 6 July 2001. As a consequence, the Guarantors cannot be declared bankrupt (but note that the Issuer can be declared bankrupt). As mentioned above, they can however be liquidated at the end of their statutory term, should such term not be renewed. The same applies if the general assembly of shareholders of a Guarantor, as convened upon request of 75% of the participating municipalities, would decide with a 75% majority of the votes cast by the participating municipalities to dissolve such Guarantor prior to the end of its statutory term.

#### *Immunity of execution*

The Guarantors are public law entities. Under Belgian law, such entities have the duty to perform at all times their tasks of public service (i.e. the concept of the continuity of the public service). Pursuant to Article 1412bis of the Belgian Judicial Code, assets owned by a public law entity (such as the Guarantors) benefit from an immunity of execution as a result of which they cannot be seized. This immunity of execution does not apply to assets that are manifestly not useful for the performance or the continuity of the public service.

This means that e.g. the distribution networks (cables and pipelines) owned by a Guarantor cannot be seized by the Bondholders in case of default. Although this limits the enforceability of the obligations of the Guarantors, the upside is that the Guarantor will be in a position to continue to perform its duties of public service and thus generate revenues. This immunity of execution is not an immunity of jurisdiction, *ie* the Guarantors can be brought before a court and be condemned notwithstanding this immunity. As at 31 December 2016, property, plant and equipment (which includes the value of the distribution grid infrastructure) amounted to EUR 7,804.1 million on a total asset base of EUR 9,617.8 million (IFRS figures for the Eandis Economic Group).

The Issuer not being a public law entity and not being the owner of the (strategic) distribution system assets, the Issuer would in principle not be subject to immunity. However, as the shareholders of the Issuer are public law entities and the Issuer operates these distribution system assets, it cannot be excluded that a court would grant certain of the assets of the Issuer the benefit of such immunity. The Issuer does, however, not benefit from immunity against judgements being rendered against it.

#### *Risks related to the liability regime applicable to the Flemish DSOs*

Articles 4.1.11/1-5 of the Energy Decree (as introduced by the Flemish Decree of 20 December 2013<sup>9</sup>) impose far-reaching rules on the liability of DSOs. The Energy Decree *inter alia* provides for a compensatory payment obligation for the DSOs in case of damages suffered by the grid user in situations of power disturbances, delays for connections or reconnections to the grids and extended unplanned power outages. For instance in case of a delay to establish a connection, a DSO is liable to pay a daily compensation of EUR 25 for a consumer grid user, EUR 50 to a non-consumer grid user applying for a simple connection and EUR 100 to a non-consumer grid user which has sought a connection with detail

<sup>9</sup> In Dutch: Decreet van 20 december 2013 houdende wijziging van het Energiedecreet van 8 mei 2009 wat betreft de aansprakelijkheid van netbeheerders ("*Flemish Decree of 20 December 2013 amending the Energy Decree of 8 May 2009 regarding the liability of grid operators*").



study. In addition, if an extended unplanned power outage occurs (i.e. an outage with a technical cause lasting at least four hours), a DSO may be held liable for an amount of EUR 35 towards consumers (increased with EUR 20 for every additional four hours) and towards professional users for an amount of 20% of the distribution costs paid in the previous month by that user with a minimum of EUR 35 (increased with EUR 20 for every additional four hours of outage). It should be noted that a DSO's liability for damages, excluding personal damages, caused by power disturbances is in any event limited to EUR 2 million per incident and that these damages can never surpass the amount necessary to repair all damages suffered.

In contrast to general Belgian tort law the DSOs' liability is in certain cases based on the principles of strict liability and in others the burden of proof is imposed on the DSO and not on the grid user. In addition, the Decree extends the scope of liability of a DSO to indirect damages (loss of income, loss of profits,...) and immaterial damages (commercial damage,...).

The current liability regime is broader and more stringent than the general liability regime under Belgian law. Whilst the Guarantors could thus in theory be faced with a high number and amounts of claims and substantial litigation costs, the actual amount of claims over 2015 and 2016 were limited (i.e. an amount of EUR 24,343.46 for 2015, and EUR 67,929.99 for 2016).

*A failure of the Issuer to remain appointed as operating company of the Guarantors would seriously endanger the Issuer's viability*

The Issuer's shareholders, seven of the Flemish DSOs, have appointed the Issuer as their operating company. This appointment is in line with the Energy Decree that enables DSOs to make use of a common operating company. However, there is a remote risk that some or all of the DSOs that are currently using the Issuer as their operating company, decide to terminate their cooperation with Eandis System Operator, thus endangering the latter's viability and its ability to repay the principal and/or the interests on the Bonds. In practice, this risk is mitigated by the continued existence of the Guarantees and the fact that every termination of cooperation needs the approval by the shareholders' meeting of the relevant DSO with a majority of at least 75 per cent.

*Adaptation of the articles of association of Sibelgas to comply with the DIS*

Sibelgas as a cross-regional intermunicipal entity became subject to the Flemish supervisory authority (*Toezichhoudende Overheid*) as of 1 July 2015 and was required to adapt its articles of association by 30 June 2015 to the Flemish Decree on Intermunicipal Cooperation of 6 July 2001 (the "**DIS**"). Sibelgas adapted its articles on 30 June 2015 but on 12 October 2015 the competent Minister decided that some of the amendments were still not complying with the provisions of the DIS. On 28 March 2017 Sibelgas adapted its articles accordingly. The Minister has a period of 90 calendar days to accept or reject such amendments and failing such a decision the new articles will be deemed to be approved. Theoretically, as Sibelgas has not adapted its articles of association in a manner that is compliant with the DIS, any shareholder, interested party or the competent Minister could request the Court of First Instance to dissolve this intermunicipal entity. The risk is rather remote as Sibelgas has taken the steps to adopt new articles of association and is waiting for a formal confirmation as to the compliance of these new provisions with the DIS.

### ***Financial Risks of the Business***

#### *Interest rate risk*

Changes in interest rates during a particular tariff period will only be recovered in a subsequent tariff period (except in the event of an exceptional change in charges in which case a request can be made for an amendment of the tariffs within the same tariff period). To minimise this pre-financing, the Issuer's and the Guarantors' boards of directors strive at achieving an optimal ratio of fixed and variable interest rates. At the request of the VREG, interest rate swaps have been entered into by the Guarantors in relation to all outstanding loans with variable interest rate. The fair value of the interest rate swaps entered into by the Guarantor amounted, as at 31 December 2016, to EUR 131 million. In addition, while the current tariff methodology has departed from the embedded debt approach applied in previous regulatory periods, whereby the cost of debt allowance was set to cover the actual cost paid by a DSO on its borrowings, a favourable regime still applies to the Guarantors' historical financing whereby debt commitments entered

into prior to the current regulatory period are given a different weighting (see below *Cost of debt* in section 3.5 in "*Part VIII - Regulatory Framework applicable to the Flemish DSOs*").

#### *Risks associated with financial debt outstanding*

The access of the Issuer and the Guarantors to global sources of financing to cover their financing needs or the repayment of their debt could be impaired by the deterioration of financial markets. As at 31 December 2016, Eandis Economic Group's total long-term debt amounted to EUR 5,244.4 million. In this amount, bonds represent an amount of EUR 3,397.2 million and bank loans represent EUR 2,202.6 million (current portion of long-term debt included in the amounts mentioned). Short-term debt at 31 December 2016 amounted to EUR 766.7 million, of which EUR 411.3 million short-term debt and EUR 355.4 million the current portion of long-term debt. The Eandis Economic Group's total of equity and liabilities as at 31 December 2016 was EUR 9,617.8 million.

The total external indebtedness of the Issuer amounts to EUR 3,808 million as at 31 December 2016, of which 3,247 million long term indebtedness. As at 31 December 2016, the ratio of long-term short-term interest bearing loans and borrowings as a percentage of total assets of the Issuer was 88%. The same ratio for the Eandis Economic Group as at 31 December 2016 was 63%.

Section 2.6 in "*Part X - Selected Financial Information*" provides further information on the financing of the Eandis Economic Group, and provides a breakdown for the Issuer and each Guarantor of such indebtedness. All indebtedness of the Issuer and the Guarantors is unsecured. All long term indebtedness of the Issuer is guaranteed by each of the Guarantors in proportion to their participation in the share capital of the Issuer as at the date of the entry into the financing arrangements.

The level of debt of the Issuer and the Guarantors might:

- make it more difficult for the Issuer and the Guarantors to satisfy their obligations, including interest payments;
- somewhat limit their ability to obtain additional financing to operate their business;
- to a certain degree limit their financial flexibility in planning for and reacting to industry changes;
- increase their vulnerability to general adverse economic and industry conditions; and
- require them to dedicate a substantial portion of their cash flows to payments on debt, reducing the availability of their cash flows for other purposes.

The Issuer and the Guarantors may borrow additional funds to support their capital expenditures and working capital needs and to finance future acquisitions, e.g. in the form of bank loans or other debt instruments.

#### *The Issuer is dependent on the cash flow generated by the Guarantors to service its debt obligations*

The proceeds of financing attracted by the Issuer are on-lent by the Issuer to the Guarantors at cost. Any obligation of the Issuer towards the providers of such financing is hence covered by a receivable on the Guarantors. Outside raising monies in the capital markets with the guarantee of the Guarantors, the Issuer does not generate any profit, as all its expenses are invoiced at cost to the Guarantors. The Guarantors are the owners of the network, and invoice the energy suppliers for the use of the network. Therefore, and outside refinancing attracted by the Issuer, the Issuer is dependent on the cash flow generated by the Guarantors, and used for the repayment of, or payment of interest on, the loans granted by the Issuer to such Guarantor to service its debt.

The ability of the Guarantors to generate cash flow primarily depends on the regulatory framework and the regulated tariffs (please see in particular the risk factors *The regulatory framework is evolving, which may affect the Issuer's and the Guarantors' operational and financial performance* and *Tariff decisions by the competent regulator may negatively affect the Guarantors' operations* in "*Part II – Risk Factors*"), as well as on their future operating performance.

Changing conditions in the credit markets and the level of the outstanding debt of the Issuer and the Guarantors can make the access to financing more expensive than anticipated and could result in greater

financial vulnerability. Consequently, the Issuer and the Guarantors cannot assure investors that they will have sufficient cash flows to pay the principal, premium, if any, and interest on their debt. If the cash flows and capital resources are insufficient to allow the Issuer and the Guarantors to make scheduled payments on their debt, the Issuer and the Guarantors may have to reduce or delay capital expenditures, sell assets, seek additional capital or restructure or refinance their debt. There can be no assurance that the terms of their debt will allow these alternative measures or that such measures would satisfy their scheduled debt service obligations. If the Issuer and the Guarantors cannot make scheduled payments on their debt, they will be in default and, as a result:

- their debt holders could declare all outstanding principal and interest to be due and payable; and
- their lenders could terminate their commitments and commence foreclosure proceedings against its assets.

#### *Funding risk*

Funding risk is the risk that the Issuer and the Guarantors will be unable to access the funds that they need when it comes to refinance their debt or through the failure to meet the terms of their credit facilities. As part of the mitigation efforts regarding the funding risk, Eandis System Operator and the Guarantors aim at a diversification of financing sources. Short term liquidity risk is managed on a daily basis with funding needs being fully covered through the availability of credit lines and commercial paper, partially on a committed basis. Cash is maintained, where necessary, to guarantee the solvency and flexibility of the Issuer and the Guarantors at all times. Please refer to section 2.6 in "*Part X - Selected Financial Information*" for more information hereon.

#### *Counterparty credit risk*

The Guarantors only have a limited number of counterparties, i.e. the energy suppliers. The Guarantors are exposed to counterparty credit risk, *ie* the risk that one or more of such counterparties has financial difficulties as a consequence of which it is unable to comply with its financial obligations towards the Eandis Economic Group. However, energy suppliers that wish to use the networks owned by the Guarantors need to enter into an agreement with the Guarantors the terms of which are set by the VREG, which agreement contains safeguards in respect of the credit quality of such energy supplier. More in particular, the energy suppliers are required either (i) to have a minimum rating of "A" from Standard & Poor's or Fitch, or A3 from Moody's (or issue a parent guarantee from an entity having such rating), (ii) to comply with a set of financial ratios, (or issue a parent guarantee from an entity which complies with such financial covenants), or (iii) to issue a first demand bank guarantee from a financial institution having a rating as aforesaid for an amount determined on the basis of the expected amounts payable by such energy supplier during a 3 month period.

#### *Risks related to pension liabilities*

The Issuer has granted its (former) employees a range of pensions and other post-employment benefit plans, both of the defined contribution type, as well as of the defined benefit type. The financing of these post-employment plans is carried out by employee contributions and employer contributions which are deposited in pension funds.

For the defined contribution plans, the Issuer is faced with the investment risk to be able to continue to cover the level of the guaranteed interest rates, as fixed by the relevant Belgian legislation, irrespective of the level of interest rates on the financial markets.

For the defined benefit plans, the Issuer is also confronted with the investment risk related to the plan beneficiaries' entitlement to the contractual lump sum to be paid out to them on their retirement.

For all pension and post-employment benefit plans, the investment risk is linked to the discount rate used for calculating the present value of the plan liability. Decreases in the overall market interest rates will increase the plan liabilities, partially offset by an increase on the plan's debt investments.

The Issuer's liabilities with respect to pensions and post-employment benefits are also impacted by the estimates used on the mortality of plan participants, both during and after their employment. An increase in their life expectancy will increase the plan's liability.

Finally, and for the defined benefit plan liabilities only, there is also the risk related to the future salaries of the plan participants who have not yet reached their retirement. A salary increase will trigger an increase in the plan's liability.

As of 31 December 2016, the total defined benefit obligation and long-term employee benefits (a range of pensions and other post-employment benefit plans) amounts to EUR 931 million. The fair value of the plan assets amounts to EUR 672 million. Consequently, as at 31 December 2016, the difference between the obligations and the assets amounts to EUR 259 million.

Please refer to Note 19 (*Employee Benefit Liability*) in the consolidated financial statements of the Issuer for the financial year 2016 and to Note 23 (*Pensions and other post-employment benefit plans*) in the consolidated financial statements of the Eandis Economic Group for more information hereon.

The Issuer and the relevant pension funds try to mitigate the aforementioned risks together by closely monitoring the parameters impacting the plans' liabilities and by applying actuarial methods deemed the most appropriate to the liabilities in case.

#### *Risks related to the use of derivative financial instruments*

The Eandis Economic Group has entered into a number of interest rate swaps in order to convert variable interest rates on long-term loans into fixed interest rates. The fair value of these derivative financial instruments (and the changes therein) are recognized in the statements of profit or loss according to IFRS. The current fair value, EUR 131 million as at 31 December 2016, represents a payable by the Eandis Economic Group. Fair values are calculated on the basis of the discounted expected future cash flows, taking into account current market interest rates and the yield curve for the investment's remaining maturity.

Volatility in the derivatives' fair value might negatively impact the Eandis Economic Group's financial results and financial capacity.

#### *Other risks of a financial nature*

Additional financial risks may stem from incorrect or insufficient accounting data or inadequate accounting procedures. Both Eandis System Operator's and the Guarantors' financial statements and accounting data/procedures are subject to an extensive and thorough control by their external auditors which should mitigate these risks.

#### ***Operational Risks of the Business***

*Eandis System Operator may be held liable in case of security of supply issues, distribution system disruptions or system breakdowns.*

The Issuer foresees that the shift towards decentralised and renewable electricity production will continue. At the regional and national level, and within the European framework, the Issuer is analysing how the rising number of decentralised electricity generation units can be integrated into the electricity distribution system while ensuring the stability and viability of the system. This development, as well as the adaptation from low calorific gas to high calorific gas of parts of the gas distribution network, is subject to prior approvals and permits, delivered by a range of authorities. Obtaining these approvals and permits in a timely fashion is an uncertainty for the timely implementation of these projects. In addition, these approvals and permits may be challenged before the competent courts.

Although the distribution system networks operated by Eandis System Operator are among the most reliable in Europe, incidents in the systems may lead to a local or a general interruption of supply. Such outages may be caused by natural phenomena, unforeseen incidents or operational problems. The general terms and conditions of Eandis System Operator's and the Guarantors' standard contracts aim at limiting their liability to a reasonable level. Insurance policies are further designed to offset the financial

repercussions of this risk even further. The insurance policies of the Issuer and the Guarantors relating to "Fire – all risks" include cover for terrorism in accordance with the Royal Decree of 24 December 1992<sup>10</sup>.

*Eandis System Operator operates facilities that may cause significant harm to its personnel or third parties*

The Issuer operates facilities that may cause significant harm to the human environment or for which accidents or external attacks may have serious consequences.

Since the gas and electricity distribution systems operated by Eandis System Operator cover large geographic areas, and although all reasonable precautions and safety measures have been put in place, they are vulnerable to possible acts of sabotage or terrorism. Such acts may seriously disrupt the continuity of service.

*A failure of IT systems and processes used by the Issuer constitutes a considerable risk*

Eandis System Operator's operations depend, to a large extent, on its IT system (including hard- and software, but also a glass fibre network used for communication purposes). This IT system is essential for an efficient and reliable operation of the electricity and gas networks operated by Eandis System Operator.

Eandis System Operator has taken extensive protective measures with a view to safeguard its IT system. However, these measures cannot guarantee that no important system failures will occur.

*Risks associated with the services delivered by Eandis System Operator*

If the services rendered by Eandis System Operator to external customers in its core business activities (e.g. infrastructure operations in the public domain or for the benefit of residential and other energy end users) turn out to be insufficient or of a below par quality level, this might lead to a decline in the appreciation for Eandis System Operator as an operating company by shareholders, stakeholders or public authorities. In the longer run, this might endanger Eandis System Operator in its position as the operating company for the Guarantors.

*Eandis System Operator and the Guarantors may incur significant costs to comply with environmental and city planning laws*

The Issuer and Guarantors may be affected by expenditures needed to keep up with environmental and city planning laws and regulations, including costs associated with implementing preventive or curative measures, permit refusals or settling third-party claims.

The Guarantors' policy has been developed and is monitored in such a way as to effectively manage these regulatory risks. Where a Guarantor is in any way liable for decontamination, the appropriate provisions are created. However, further amendments to environmental and city planning laws or regulations may mean that the relevant Guarantor has to create additional contingency reserves.

*Eandis System Operator may incur significant losses if it cannot succeed in attracting and retaining enough qualified and competent personnel*

Eandis System Operator pursues an active recruitment policy which aims at maintaining an appropriate level of expertise and know-how in a tight labour market, given the highly specialised nature of the business. If, however, the company does not succeed in attracting and retaining the staff required for its activities, this may adversely impact its operations.

*Risk of defective databases*

If the data in Eandis System Operator's databases turns out to be insufficient or incorrect, this may severely hinder the company in carrying out its duties and will result in extra costs or losses.

---

<sup>10</sup> Royal Decree in respect of the insurance against fire and other dangers relating to simple risks (In Dutch: *Koninklijk Besluit betreffende de verzekering tegen brand en andere gevaren wat de eenvoudige risico's betreft.*)

Eandis System Operator takes extensive measures to keep its databases up-to-date and protected. However, in case of inadequacies or loss, its operations may be severely hindered.

*Risks related with the relocation of cables or pipelines*

In certain circumstances the Guarantors may be required by third parties or by regulators to relocate certain cables or pipelines at their own expense. Such relocation costs may be substantial, and may influence the financial position of the Issuer and/or the Guarantors.

*Risks associated with Eandis System Operator's corporate strategy*

The corporate strategy outlined by Eandis System Operator may be challenged by several external factors, forcing it to adapt its strategy. These external factors may include new legislation or regulation, an inefficient market model, a lack of available resources (financial, logistical, human resources or otherwise) on the market. Internally, the corporate strategy may be challenged by a defective strategic planning, or the inadequate management of projects.

*Risks related to corporate governance at Eandis System Operator and/or the Guarantors*

Although Eandis System Operator and the Guarantors have put in place an extensive set of detailed governance rules and procedures, it cannot be completely ruled out that e.g. an inadequate treatment of complaints, an inadequate functioning of their audit or governance bodies, an inefficiency in its/their company administration, might have adverse consequences on the Issuer's and/or the Eandis Economic Group's interests.

**Risk factors in relation to the Bonds**

*The Bonds may not be a suitable investment for all investors.*

Each potential investor in the Bonds must determine the suitability of that investment in light of its own circumstances. In particular, each potential investor should:

- (i) have sufficient knowledge and experience to make a meaningful evaluation of the Bonds, the merits and risks of investing in the Bonds and the information contained or incorporated by reference in this Prospectus or any applicable supplement;
- (ii) have access to, and knowledge of, appropriate analytical tools to evaluate, in the context of its particular financial situation, an investment in the Bonds and the impact the Bonds will have on its overall investment portfolio;
- (iii) have sufficient financial resources and liquidity to bear all of the risks of an investment in the Bonds, including where the currency for principal or interest payments is different from the potential Investor's currency;
- (iv) understand thoroughly the terms of the Bonds and be familiar with the behaviour of any relevant financial markets; and
- (v) be able to evaluate (either alone or with the help of a financial adviser) possible scenarios for economic, interest rate and other factors that may affect its investment and its ability to bear the applicable risks.

A potential investor should not invest in the Bonds unless it has the expertise (either alone or with a financial adviser) to evaluate how the Bonds will perform under changing conditions, the resulting effects on the value of the Bonds and the impact the investment will have on the potential Investor's overall investment portfolio. Investors should note that they may lose all or part of their investment.

Each prospective investor in the Bonds must determine, based on its own independent review and such professional advice as it deems appropriate under the circumstances, that its acquisition of the Bonds is fully consistent with its financial needs, objectives and condition, complies and is fully consistent with all investment policies, guidelines and restrictions applicable to it and is a fit, proper and suitable investment for it, notwithstanding the clear and substantial risks inherent in investing in or holding the Bonds.

***The Bonds and the Guarantees are unsecured obligations of the Issuer and the Guarantors, and there is no limitation on issuing further debt.***

Neither the Issuer, nor the Guarantors are prohibited from issuing further debt or granting securities ranking *pari passu* with the Bonds or the Guarantees. The Bonds do not limit the ability of the Issuer or the Guarantors to incur indebtedness or issue securities. This could have an impact on their ability to meet its obligations under the Bonds or could cause the value of the Bonds to decrease.

The right of the Bondholders to receive payment on the Bonds is unsecured. In the event of liquidation, dissolution, reorganisation, bankruptcy or similar procedure affecting the Issuer or the Guarantors, the holders of secured indebtedness will be repaid first with the proceeds from the enforcement of such security.

All long term indebtedness of the Issuer and the Guarantors is currently unsecured. If security is provided by the Issuer, its subsidiaries or any Guarantors in respect of any present or future indebtedness, in the form of or evidenced by notes, bonds, debentures, loan stock, treasury notes, commercial paper, *Namenschuldverschreibungen* or other similar debt instruments which are or are capable of being, quoted, listed or ordinarily dealt in or traded on any stock exchange, or in any securities market (including, without limitation, any over the counter market) (as provided in more detail in the Conditions), the same or similar security is to be granted for the benefit of the Bondholders pursuant to Condition 3 (*Negative Pledge*).

The Issuer and the Guarantors are not restricted to grant security for other indebtedness (including bank loans) and it cannot be excluded that the Issuer or the Guarantors would enter into secured bank loans in the future, which will then be first with the proceeds from the enforcement of such security in the event of liquidation, dissolution, reorganisation, bankruptcy or similar procedure affecting the Issuer or the Guarantors.

***The payment of all amounts in respect of the Bonds is guaranteed on a several but not joint basis, subject to the pro rata limitations.***

The obligations of each Guarantor under its respective Guarantee are on a several but not joint basis, meaning that each Bondholder will need to make a claim against each of the seven Guarantors, each claim for a portion of the total claim of such Bondholder against the Issuer. The obligations of each Guarantor under its respective Guarantee shall, at all times, be limited to the proportional share such Guarantor holds in the share capital of the Issuer. If any of the Guarantors would become insolvent, an investor would not benefit from a guarantee for the full amount of the obligations of the Issuer in respect of the Bonds. As of the date of this Prospectus, the share capital of the Issuer is held as set out in section 2.3 of "*Part IX – Description of the Issuer and the Guarantors*". The holding of the share capital of the Issuer may evolve over time.

***There may be no active trading market for the Bonds.***

The only manner for the Bondholders to convert their investment in the Bonds into cash before their maturity date is to sell them at the applicable market price at that moment. The price can be less than the nominal value of the Bonds. The Bonds will be new securities which may not be widely distributed and for which there is currently no active trading market. An application has been submitted for admission of the Bonds to trading on the regulated market of Euronext Brussels. If the Bonds are traded after their initial issuance, they may trade at a discount to their initial offering price, depending upon prevailing interest rates, the market for similar securities, general economic conditions and the financial condition of the Issuer. There is no assurance that an active trading market will develop. Accordingly, there is no assurance as to the development or liquidity of any trading market for the Bonds. Therefore, investors may not be able to sell their Bonds easily or at prices that will provide them with a yield comparable to similar investments that have a developed secondary market. Illiquidity may have a severely adverse effect on the market value of the Bonds. Furthermore, it cannot be guaranteed that the admission to listing and trading once approved will be maintained.

***No tax gross-up protection.***

Potential investors should be aware that the Conditions of the Bonds (unlike the conditions of the existing bonds of the Issuer) do not require the Issuer or the Guarantors to gross up the net payments received by a

Bondholder in relation to the Bonds with the amounts withheld or deducted for Belgian tax purposes. In case the Belgian tax rules would be amended such that Bondholders holding their Bonds in an exempt securities account in the NBB-SSS are no longer exempt from Belgian withholding tax, such Bondholders will bear the risk that Belgian withholding tax will be applied to and withheld from the payments to be received in relation to the Bonds.

If the Issuer, a Guarantor, the NBB, the Agent or any other person is required to make any withholding or deduction for, or on account of, any present or future taxes, duties or charges of whatever nature in respect of any payment in respect of the Bonds, the Issuer, the Guarantor, the NBB, the Agent or that other person shall make such payment after such withholding or deduction has been made and will account to the relevant authorities for the amount so required to be withheld or deducted.

The Bondholders (and no other person) will be liable for, and be obliged to pay, any tax, duty, charge, withholding or other payment whatsoever as may arise as a result of or in connection with the ownership, transfer or payment in respect of the Bonds.

***The Conditions may be modified and defaults may be waived by the defined majorities of the meetings of Bondholders.***

The Conditions contain provisions for calling meetings of Bondholders to consider matters affecting their interests generally. These provisions permit defined majorities to bind all Bondholders, including Bondholders who did not attend and vote at the relevant meeting and Bondholders who voted in a manner contrary to the majority.

***The Issuer and the Guarantors may not be able to repay the Bonds.***

The Issuer and the Guarantors may not be able to repay the Bonds at their maturity. The Issuer or alternatively the Guarantors, may also be required to repay all or part of the Bonds upon the occurrence of an Event of Default (as defined in Condition 9 (*Events of Default*)). If the Bondholders were to request repayment of their Bonds upon the occurrence of an Event of Default, the Issuer and the Guarantors cannot assure that they will be able to pay the required amount in full. The Issuer's and the Guarantors' ability to repay the Bonds will depend on their respective financial condition (including their cash position resulting from their ability to receive income and dividends from their subsidiaries) at the time of the requested repayment, and may be limited by law, by the terms of its indebtedness and by the agreements that they may have entered into on or before such date, which may replace, supplement or amend its existing or future indebtedness. The Issuer's and the Guarantors' failure to repay the Bonds may result in an event of default under the terms of other outstanding indebtedness.

***Impact of fees, commissions and/or inducements on the issue price and/or offer price.***

Investors should note that the issue price and/or offer price of any issue of Bonds may include certain additional fees and costs, in particular, in relation to any actual or potential investor in the Bonds that is not a Qualified Investor (the "**Retail Investors**"), a selling and distribution fee of 1.875 per cent. (the "**Retail Fee**") and, in relation to *gekwalificeerde beleggers/investisseurs qualifiés* within the meaning of Article 10 of the Prospectus Law, of Directive 2004/39/EC or of the applicable laws of any relevant jurisdiction within the European Economic Area (the "**Qualified Investors**"), a fee equal to or lower than such Retail Fee as may be determined by the Joint Lead Managers. Any such fees may not be taken into account for the purposes of determining the price of such Bonds on the secondary market and could result in a difference between the original issue price and/or offer price, the theoretical value of such Bonds, and/or the actual bid/offer price quoted by any intermediary in the secondary market.

Any such difference may have an adverse effect on the value of Bonds, particularly immediately following the offer and the issue date of the Bonds, where any such fees and/or costs may be deducted from the price at which such Bonds can be sold by the initial investor in the secondary market.

***The Bonds may be redeemed prior to their maturity.***

In the event of the occurrence of an Event of Default the Bonds may be redeemed prior to their maturity in accordance with the Conditions. In such circumstances an investor may not be able to reinvest the repayment proceeds (if any) at a yield comparable to that of the Bonds. Investors need to be aware that in the event of a redemption prior to maturity in accordance with the Conditions, they might receive a redemption amount which is lower than the Issue Price.



***The market value of the Bonds may be affected by the creditworthiness of the Issuer and the Guarantors.***

The value of the Bonds may be affected by the creditworthiness of the Issuer and the Guarantors and a number of additional factors, such as market interest and yield rates and the time remaining to the Maturity Date and more generally all economic, financial and political events in any country, including factors affecting capital markets generally and the stock exchanges on which the Bonds are traded. The price at which a Bondholder will be able to sell the Bonds prior to maturity may be at a discount, which could be substantial, from the issue price or the purchase price paid by such purchaser.

***Change of control put option.***

The Conditions provide that the Bondholders have the right to require the Issuer to redeem all or any part of such holder's Bonds at the Change of Control Put Redemption Amount (as defined in the Conditions), upon the occurrence of a Change of Control (as defined in the Conditions) (the "**Change of Control Put**"). If the procedure set out in the Conditions has been followed, the Issuer cannot refuse to redeem the Bonds. Bondholders should be aware that, in the event that holders of a significant proportion of the Bonds exercise their put option under Condition 5(b) (*Redemption at the option of the Bondholders following a Change of Control*), Bonds in respect of which the Change of Control Put is not exercised may be illiquid and difficult to trade.

Potential investors should also be aware that the Change of Control Put can only be exercised in specified circumstances of a "Change of Control" as defined in the Conditions, which may not cover all situations where a change of control may occur or where successive changes of control occur in relation to the Issuer and any of the Guarantors.

Bondholders deciding to exercise the Change of Control Put have to do this through the bank or other financial intermediary (if any) through which they hold the Bonds (the "**Financial Intermediary**") and are advised to check when such Financial Intermediary would require the receipt of instructions and Change of Control Notice in order to meet the deadlines for such exercise to be effective.

The fees and/or costs, if any, of the relevant Financial Intermediary shall be borne by the relevant holders.

***Interest rate risks may affect the value of the Bonds.***

An investment in the Bonds involves the risk that subsequent changes in market interest rates may adversely affect the value of the Bonds. The Bonds provide a fixed interest rate until the Maturity Date. Investment in the Bonds involves the risk that subsequent changes in market interest rates may adversely affect the value of the Bonds. The longer the maturity of bonds, the more exposed bonds are to fluctuations in market interest rates. An increase in the market interest rates can result in the Bonds trading at prices lower than the nominal amount of such Bonds.

***Risk of inflation.***

The inflation risk is the risk of future value of money. Inflation will affect the real yield of an investment in the Bonds. The higher the rate of inflation, the lower the real yield of a Bond because the purchasing power of the interest received by the investor will be reduced through inflation. In case the rate of inflation is higher than the yield of the Bonds, the real yield may actually be negative.

***Limited restrictions on corporate reorganisations.***

The Conditions do not prohibit the Issuer from conducting a reorganisation, without the consent of the Bondholders, whereby its tasks in relation to the management of the electricity and gas grids are transferred to a third party or any of the Guarantors loses its licence of DSO in the designated areas in Flanders or undergoes a reorganisation whereby its tasks in relation to the electricity and gas grids are transferred to a third party, provided that (i) the successor of the Issuer as the operating company of the Guarantors is a Permitted Successor Entity (as defined in the Conditions) and proviso (ii) is satisfied, or (ii) the number of EAN-codes in the designated area in respect of which the Issuer or a Permitted Successor Entity ceases to be the operating company represents 10 per cent. or less of the aggregate number of EAN-codes in the whole of the designated area covered by the Issuer on the date of the Prospectus. In such case no Event of Default shall occur, and – where such reorganisation involves the succession of the Issuer or a Guarantor, the successor issuer shall assume all rights and obligations of the

Issuer in respect of the Bonds (or, in respect of a Guarantor, the successor guarantor shall assume all rights and obligations of the Guarantor under the guarantee). Please also refer to Section 8 in "*Part IX - Description of the Issuer and the Guarantors*".

***Taxation.***

Potential purchasers and sellers of the Bonds should be aware that they may be required to pay taxes or other documentary charges or duties in accordance with the laws and practices of the country where the Bonds are transferred or other jurisdictions. In addition, potential investors should be aware that tax regulations and their application by the relevant taxation authorities change from time to time. Accordingly, it is not possible to predict the precise tax treatment which will apply at any given time. Potential investors are advised not to rely upon the tax summary contained in this Prospectus but to ask for their own tax advisers' advice on their individual taxation with respect to the acquisition, sale and redemption of the Bonds. Only these advisers are in a position to duly consider the specific situation of the potential investor. This investment consideration has to be read in connection with "*Part XII – Taxation*".

***A change in the governing law and practices may affect the Conditions.***

The Conditions of the Bonds are based on the laws of Belgium and interpretations thereof and practices in effect as at the date of this Prospectus. No assurance can be given as to the impact of any possible judicial decision or change to the laws of Belgium, the official application, interpretation or the administrative practice after the date of this Prospectus.

***Relationship with the Issuer.***

All notices and payments to be delivered to the Bondholders will be distributed by the Issuer to such Bondholders in accordance with the Conditions. In the event that a Bondholder does not receive such notices or payments, its rights may be prejudiced but it may not have a direct claim against the Issuer therefore.

***Reliance on the procedures of the NBB-SSS, Euroclear and Clearstream, Luxembourg for the transfer of the Bonds, payments in respect of the Bonds and communications with the Issuer.***

The Bonds will be issued in dematerialised form in accordance with article 3, §2 of the Belgian law of 14 December 2005 on the suppression of bearer securities and the articles of association of the Issuer and cannot be physically delivered. The Bonds will be represented exclusively by book-entries in the records of the NBB-SSS.

Access to the NBB-SSS is available through its NBB-SSS participants whose membership extends to securities such as the Bonds. NBB-SSS participants include certain banks, stockbrokers (*beursvennootschappen/sociétés de bourse*) and Euroclear and Clearstream, Luxembourg.

Transfers of the Bonds will be effected between the NBB-SSS participants in accordance with the rules and operating procedures of the NBB-SSS. Transfers between investors will be effected in accordance with the respective rules and operating procedures of the NBB-SSS participants through which they hold their Bonds.

The Issuer and the Domiciliary Agent will have no responsibility for the proper performance by the NBB-SSS or the NBB-SSS participants of their obligations under their respective rules and operating procedures.

A Bondholder must rely on the procedures of the NBB-SSS, Euroclear and Clearstream, Luxembourg to receive payments under the Bonds. The Issuer will have no responsibility or liability for the records relating to, or payments made in respect of, the Bonds within the NBB-SSS.

***The Domiciliary Agent is not required to segregate amounts received by it in respect of Bonds settled through the NBB-SSS.***

The Conditions of the Bonds and the Agency Agreement provide that the Agent will debit the relevant account of the Issuer and use such funds to make payment to the Bondholders. The Agency Agreement provides that the Domiciliary Agent will, simultaneously upon receipt of the relevant amounts into its

account, pay any amounts due and payable in respect of the relevant Bonds to the Bondholders directly or through the NBB-SSS. However, the Domiciliary Agent is not required to segregate any such amounts received by it in respect of the Bonds from its other assets. In the event that the Agent would be subject to insolvency proceedings at any time when it held any such amounts, Bondholders would no longer have a claim against the Issuer in respect of such amounts. The Bondholders would be required to claim such amounts from the Domiciliary Agent in accordance with applicable Belgian insolvency laws. In such case it may occur that there are insufficient assets remaining which can be distributed to, and be used to pay, the Bondholders.

***Exchange rate risks and exchange controls may affect payments in relation to the Bonds.***

The Issuer may pay principal and interest on the Bonds in euro and the Guarantors will make any payments under their respective Guarantee in euro. This presents certain risks relating to currency conversions if an investor's financial activities are denominated principally in a currency or currency unit (the "**Investor's Currency**") other than euro. These include the risk that exchange rates may significantly change (including changes due to devaluation of euro or revaluation of the Investor's Currency) and the risk that authorities with jurisdiction over the Investor's Currency may impose or modify exchange controls. An appreciation in the value of the Investor's Currency relative to euro would decrease (1) the Investor's Currency-equivalent yield on the Bonds, (2) the Investor's Currency equivalent value of the principal payable on the Bonds and (3) the Investor's Currency equivalent market value of the Bonds.

Government and monetary authorities may impose (as some have done in the past) exchange controls that could adversely affect an applicable exchange rate. As a result, investors may receive less interest or principal than expected, or no interest or principal.

***Potential conflicts of interest may have an adverse effect.***

The Joint Lead Managers might have conflicts of interests which could have an adverse effect to the interests of the Bondholders.

Potential investors should be aware that the Issuer and the Guarantors are involved in a general business relation or/and in specific transactions with the Joint Lead Managers and that they might have conflicts of interests which could have an adverse effect to the interests of the Bondholders. As at the date of the Prospectus, the Joint Lead Managers provide, among others, payment services, investments of liquidities, credit facilities, bank guarantees and assistance in relation to bonds and structured products to the Eandis Economic Group for which certain fees are being paid to the Joint Lead Managers by the Eandis Economic Group. As at 31 December 2016, the existing financial indebtedness of the Eandis Economic Group outstanding towards Belfius Bank SA/NV amounts to EUR 712 million and towards BNP Paribas Fortis SA/NV amounts to EUR 579 million. Potential investors should also be aware that each of the Joint Lead Managers may hold from time to time debt securities, shares or/and other financial instruments of the Issuer.

Within the framework of the normal business relationship with its banks, the Guarantors have entered, and the Issuer or another company within the Eandis Economic Group could enter into loans and other facilities with the Joint Lead Managers (via bilateral transactions or/and syndicated loans together with other banks). The terms and conditions of these debt financings may differ from the Conditions of the Bonds and certain of the terms and conditions of such debt financings could be stricter or more extensive than the Conditions of the Bonds. The terms and conditions of these debt financings may contain financial covenants which are not included in or are different from the Conditions.

The Bondholders should be aware of the fact that the Joint Lead Managers, when they act as lenders to the Issuer, the Guarantors or another company within the Eandis Economic Group (or in any other capacity whatsoever) have no fiduciary duties or other duties of any nature whatsoever *vis-à-vis* the Bondholders and are under no obligation to take into account the interests of the Bondholders.

There are no conflicts of interests between the members of the board of directors, the HR Committee, the Audit Committee and the Strategic Committee of the Issuer, and between the members of the board of directors of the Guarantors, and their respective private interests or other duties (in which respect please refer to sections 2.1 and 3.3 of "*Part IX - Description of the Issuer and the Guarantors*").

***Legal investment considerations may restrict certain investments.***

The investment activities of certain investors are subject to legal investment laws and regulations, or review or regulation by certain authorities. Each potential investor should consult its legal advisers to determine whether and to what extent (1) the Bonds are legal investments for it, (2) the Bonds can be used as collateral for various types of borrowing and (3) other restrictions apply to its purchase or pledge of the Bonds. The investors should consult their legal advisers to determine the appropriate treatment of the Bonds under any applicable risk-based capital or similar rules.

***Risk of withdrawal or cancellation of the Public Offer.***

As from the date of this Prospectus and at any time prior to the Issue Date of the Bonds, the Public Offer may be wholly or partially retracted or cancelled in accordance with the provisions of the Placement Agreement as further specified in "*Part XIII – Subscription and sale*". In this case investors who paid the Issue Price for the Bonds prior to the notification of retraction or cancellation of the Public Offer shall receive the total amounts of funds already paid by them as issue price for the Bonds. Such investor may however not receive the interest on such amount they otherwise could have earned if they had not paid the issue price for the Bonds.

***The Domiciliary, Paying, Calculation and Listing Agent does not assume any fiduciary duties or other obligations to the Bondholders and, in particular, is not obliged to make determinations which protect their interests.***

Belfius Bank NV/SA will act as the Issuer's Domiciliary, Paying, Calculation and Listing Agent. In its capacity as Domiciliary, Paying, Calculation and Listing Agent it will act in accordance with the Conditions of the Bonds in good faith and endeavour at all times to make its determinations in a commercially reasonable manner. Bondholders should, however, be aware that the Domiciliary, Paying, Calculation and Listing Agent does not assume any fiduciary or other obligations to the Bondholders and, in particular, is not obliged to make determinations which protect or further the interests of the Bondholders.

The Domiciliary, Paying, Calculation and Listing Agent may rely on any information that is reasonably believed by it to be genuine and to have been originated by the proper parties. The Domiciliary, Paying, Calculation and Listing Agent shall not be liable for the consequences to any person (including the Bondholders) for any errors or omissions in (i) the calculation by the Domiciliary, Paying, Calculation and Listing Agent of any amount due in respect of the Bonds or (ii) any determination made by the Domiciliary, Paying, Calculation and Listing Agent in relation to the Bonds or interests, in each case in the absence of bad faith or wilful default. Without prejudice to the generality of the foregoing, the Domiciliary, Paying, Calculation and Listing Agent shall not be liable for the consequences to any person (including the Bondholders) of any such errors or omissions arising as a result of (i) any information provided to the Domiciliary, Paying, Calculation and Listing Agent proving to have been incorrect or incomplete or (ii) any relevant information not being provided to the Domiciliary, Paying, Calculation and Listing Agent in a timely manner.

***Belgian insolvency laws.***

The Issuer is incorporated, and has its registered office, in Belgium and is, consequently, as a rule, subject to insolvency laws and proceedings in Belgium. The application of these insolvency laws may substantially affect the Bondholders' claim to obtain repayment (partial or in full) of the Bonds, e.g., as the result of a suspension of payments, a stay on enforcement measures or an order providing for partial repayment of the Bonds.

### PART III – DOCUMENTS INCORPORATED BY REFERENCE

This Prospectus should be read and construed in conjunction with the audited consolidated financial statements of the Issuer as of and for the year ended 31 December 2016 and as of and for the year ended 31 December 2015, together in each case with the audit report thereon, which have been subject to an audit by the auditors of the Issuer, in each case drawn up in accordance with the International Financial Reporting Standards as adopted for use in the European Union.

Such documents shall be incorporated in, and form part of this Prospectus, save that any statement contained in a document which is incorporated by reference herein shall be modified or superseded for the purpose of this Prospectus to the extent that a statement contained herein modifies or supersedes such earlier statement (whether expressly, by implication or otherwise). Any statement so modified or superseded shall not, except as so modified or superseded, constitute a part of this Prospectus. Copies of documents incorporated by reference in this Prospectus may be obtained (without charge) from the registered offices of the Issuer and the website of the Issuer ([http://www.eandis.be/eandis/ir\\_rating\\_and\\_bonds.htm](http://www.eandis.be/eandis/ir_rating_and_bonds.htm)).

The table below sets out the relevant page references for (i) the audited consolidated financial statements as of and for the financial year ended 31 December 2016 for the Issuer and (ii) the audited consolidated financial statements as of and for the financial year ended 31 December 2015 for the Issuer, as set out in the Financial Report of the Issuer for such periods.

The Issuer confirms that it has obtained the approval from its auditors to incorporate by reference in this Prospectus the statutory auditor's opinion on the consolidated financial statements as of and for the financial years ended 31 December 2016 and 31 December 2015.

Any information not listed in the cross reference list but included in the documents incorporated by reference is given for information purpose only and do not form part of this Prospectus.

#### **Audited consolidated financial statements, audit opinion and explanatory Notes of the Issuer as of and for the financial years ended 31 December 2016 and 31 December 2015**

---

##### **Eandis System Operator CVBA consolidated financial statements as of and for the year ended 31 December 2016**

Consolidated statement of profit and loss .....	Page 14
Consolidated statement of financial position.....	Page 16
Consolidated statement of cash flows .....	Page 18
Explanatory Notes.....	Pages 19 to 55
Audit opinion on the historical consolidated financial information.....	Pages 10 and 11

---

##### **Eandis System Operator CVBA consolidated financial statements as of and for the year ended 31 December 2015**

Consolidated statement of profit and loss .....	Page 12
Consolidated statement of financial position.....	Page 14
Consolidated statement of cash flows .....	Page 16
Explanatory Notes.....	Pages 17 to 51
Audit opinion on the historical consolidated financial information.....	Pages 53 and 54

## PART IV – TERMS AND CONDITIONS OF THE BONDS

*The following is the text of the terms and conditions that shall be applicable to the Bonds.*

The issue of the 2.000 per cent fixed rate bonds due 23 June 2025 for a minimum amount of EUR 150,000,000 and a maximum amount of EUR 200,000,000 (the "**Bonds**") was authorised by a resolution of the board of directors of Eandis System Operator CVBA (the "**Issuer**") on 22 February 2017.

The Bonds are issued subject to and with the benefit of an agency agreement dated on or about 6 June 2017 and entered into between the Issuer and Belfius Bank NV/SA as domiciliary agent, paying agent, calculation agent and listing agent (the "**Agent**", which expression shall include any successor as agent under the agency agreement), as may be amended, restated and/or supplemented from time to time (the "**Agency Agreement**"). The domiciliary agent, the paying agent, the calculation agent and the listing agent are referred to respectively as the "**Domiciliary Agent**", the "**Paying Agent**", the "**Calculation Agent**" and the "**Listing Agent**".

The statements in these Conditions include summaries of, and are subject to, the detailed provisions of (i) the Agency Agreement and (ii) a service contract concerning the issue of dematerialised bonds dated on or about 6 June 2017 and entered into between the Issuer, Belfius Bank NV/SA as the domiciliary agent and the National Bank of Belgium (the "**NBB**"), as may be amended, restated and/or supplemented from time to time (the "**Clearing Services Agreement**"). The Bondholders (as defined below) are bound by, and are deemed to have notice of, all the provisions of the Agency Agreement and the Clearing Services Agreement applicable to them.

The due and punctual payment and performance by the Issuer of all moneys, obligations and liabilities owed or incurred by the Issuer to the Bondholders in respect of the Bonds, whether actual, future or contingent and whether or not the Bondholder has acquired the Bond on the Issue Date (as defined below) or at a later stage, shall be unconditionally and irrevocably guaranteed on a several but not joint basis by whichever of the Guarantors (as defined below), in accordance with, and subject to the *pro rata* limitation of, its respective Guarantee (as defined below). The original of each Guarantee is held by the Agent on behalf of the Bondholders, at its specified offices.

Copies of the Agency Agreement, the Clearing Services Agreement and the Guarantees are available for inspection during normal business hours at the specified office of the Agent. On the Issue Date, the specified office of the Agent is at Pachecolaan 44, 1000 Brussels, Belgium.

References herein to "**Conditions**" or a "**Condition**" are, unless the context otherwise requires, to one or more of the numbered paragraphs below.

### 1. **FORM, TITLE AND DENOMINATION**

#### (a) **Form:**

The Bonds are issued in dematerialised form in accordance with article 3, §2 of the Belgian law of 14 December 2005 on the suppression of bearer securities (*Wet houdende afschaffing van de effecten aan toonder/Loi portant suppression des titres au porteur*) and the articles of association of the Issuer and cannot be physically delivered. The Bonds are accepted for settlement through the securities settlement system operated by the NBB or any successor thereto (the "**NBB-SSS**") and are accordingly subject to the applicable settlement regulations, including the Belgian law of 6 August 1993 on transactions in certain securities (*Wet betreffende de transacties met bepaalde effecten/Loi relative aux opérations sur certaines valeurs mobilières*), its implementing Belgian Royal Decrees of 26 May 1994 and 14 June 1994 (each as amended and/or re-enacted as their application is modified by other provisions from time to time) and the terms and conditions governing the participation in the NBB-SSS and its annexes, as issued or modified by the NBB from time to time (the laws, decrees and rules mentioned in this Condition being referred to herein as the "**Securities Settlement System Regulations**"). The Bonds are tradable on a fungible basis in accordance with the Coordinated Belgian Royal Decree Number 62 of 10 November 1967 relating to the deposit of fungible financial instruments and the settlement of operations on these instruments (*Gecoördineerd koninklijk besluit 62 betreffende de bewaargeving van*

*vervangbare financiële instrumenten en de vereffening van transacties op deze instrumenten/Arrêté royal coordonné 62 relatif au dépôt d'instruments financiers fongibles et à la liquidation d'opérations sur ces instruments*). The Bondholders will not be entitled to exchange the Bonds into bonds in bearer or registered form.

The Bonds will be represented by book-entries in the records of the NBB-SSS itself or participants or sub-participants in such system approved by the Belgian Financial Services and Markets Authority. The NBB-SSS maintains securities accounts in the name of authorised participants only and accordingly the NBB is the entity in charge of keeping the records. Such participants include Euroclear and Clearstream, Luxembourg. Bondholders, unless they are participants, will not hold Bonds directly with the operator of the NBB-SSS but will hold them in a securities account through a financial institution which is a participant in the NBB-SSS or which holds them through another financial institution which is such a participant.

If, at any time, the Bonds are transferred to another settlement system, not operated or not exclusively operated by the NBB, these provisions shall apply *mutatis mutandis* to such successor settlement system and successor settlement system operator or any additional settlement system and additional settlement system operator (any such clearing system, an "**Alternative Settlement System**").

(b) **Title:**

Title to the Bonds is evidenced by book-entries in the Bondholder's securities account with the NBB or with an approved participant or sub-participant of the NBB-SSS as referred to under paragraph (a) above. The person who is for the time being shown in the records of the NBB-SSS or of an approved participant or sub-participant of the NBB-SSS as the holder of a particular nominal amount of Bonds shall for all purposes be treated by the Issuer and the Agent as the holder of such nominal amount of Bonds, and the expressions "**Bondholders**" and "**holders of Bonds**" and related expressions shall be construed accordingly.

(c) **Denomination:**

The Bonds are issued in principal amounts of EUR 500 (the "**Specified Denomination**") and can only be settled through the NBB-SSS in nominal amounts equal to the Specified Denomination or integral multiples thereof.

## 2. **STATUS OF THE BONDS AND THE GUARANTEES**

(a) **Status of the Bonds:**

The Bonds constitute direct, unconditional, unsubordinated and (subject to the provisions of Condition 3 (*Negative Pledge*)) unsecured obligations of the Issuer.

The Bonds rank and shall at all times rank *pari passu* and rateably, without any preference among themselves, and equally with all other existing and future unsecured and unsubordinated obligations of the Issuer, but, in the event of insolvency, save for such obligations that may be preferred by provisions of law that are mandatory and of general application.

(b) **Status of the Guarantees:**

Each of Gaselwest, IMEA, Imewo, Intergem, Iveka, Iverlek and Sibelgas (each a "**Guarantor**" and together the "**Guarantors**") has unconditionally and irrevocably guaranteed on a several but not joint basis the due and punctual payment and performance of all moneys, obligations and liabilities owed or incurred by the Issuer to the Bondholders in respect of the Bonds, whether actual, future or contingent and whether or not the Bondholder has acquired the Bond on the Issue Date or at a later stage (the "**Guaranteed Liabilities**") by the Issuer in accordance with, and subject to, the *pro rata* limitation of, its respective guarantee in each case dated on or about 6 June 2017 (each a "**Guarantee**" and together the "**Guarantees**").

The obligations of each Guarantor under the relevant Guarantee are direct, unconditional, unsubordinated and unsecured obligations of such Guarantor and (save for certain obligations required to be preferred by law) rank equally with all other unsecured obligations of the relevant Guarantor, from time to time outstanding. The obligations of each Guarantor under its respective Guarantee are limited to the proportional share such Guarantor holds in the share capital of the Issuer as of the Issue Date as set out below.

Gaselwest holds 16.5973% of the shares in the Issuer and consequently the Guarantee of Gaselwest is limited to the due and punctual payment of 16.5973% of the Guaranteed Liabilities.

IMEA holds 13.7600% of the shares in the Issuer and consequently the Guarantee of IMEA is limited to the due and punctual payment of 13.7600% of the Guaranteed Liabilities.

Imewo holds 22.4162% of the shares in the Issuer and consequently the Guarantee of Imewo is limited to the due and punctual payment of 22.4162% of the Guaranteed Liabilities.

Intergem holds 10.9459% of the shares in the Issuer and consequently the Guarantee of Intergem is limited to the due and punctual payment of 10.9459% of the Guaranteed Liabilities.

Iveka holds 14.3432% of the shares in the Issuer and consequently the Guarantee of Iveka is limited to the due and punctual payment of 14.3432% of the Guaranteed Liabilities.

Iverlek holds 19.4302% of the shares in the Issuer and consequently the Guarantee of Iverlek is limited to the due and punctual payment of 19.4302% of the Guaranteed Liabilities.

Sibelgas holds 2.5072% of the shares in the Issuer and consequently the Guarantee of Sibelgas is limited to the due and punctual payment of 2.5072% of the Guaranteed Liabilities.

The holding of the share capital of the Issuer may evolve over time.

### 3. **NEGATIVE PLEDGE**

(a) **Restriction:**

So long as any of the Bonds remains outstanding, neither the Issuer nor any of its Subsidiaries (as defined below) nor any Guarantor will create or have outstanding any Security Interest (as defined below) upon or with respect to the whole or any part of its present or future business, undertaking, assets or revenues (including any uncalled capital) to secure any Relevant Debt (as defined below), or to secure any guarantee or indemnity in respect of any Relevant Debt, without at the same time or prior thereto according to the Bonds the same security as is created or subsisting to secure any such Relevant Debt, guarantee or indemnity or such other security as shall be approved by an extraordinary resolution of the Bondholders (in accordance with Condition 10 (*Meetings of Bondholders and Modifications*)).

(b) **Definitions:**

For the purposes of this Condition 3:

- (i) **"Relevant Debt"** means any present or future indebtedness (whether being principal, premium, interest or other amounts), in the form of or evidenced by notes, bonds, debentures, loan stock, treasury notes, commercial paper, *Namenschuldverschreibungen* or other similar debt instruments, whether issued for cash or in whole or in part for a consideration other than cash, and which are,



or are capable of being, quoted, listed or ordinarily dealt in or traded on any stock exchange, or in any securities market (including, without limitation, any over the counter market). For the avoidance of any doubt, any bank loan, *Schuldschein* or intra-group loan that is granted on the basis of a loan agreement is not Relevant Debt;

- (ii) "**Security Interest**" means any mortgage, charge, lien, pledge or other security interest, including an irrevocable mandate to establish the same and any similar concept under applicable law or any other agreement or arrangement having a similar effect; and
- (iii) "**Subsidiary**" means, at any particular time, a company or other entity which is then directly or indirectly controlled, or more than 50 per cent of whose issued share capital (or equivalent) is then beneficially owned by the Issuer and/or one or more of its respective Subsidiaries. For this purpose, for a company to be "controlled" by another means that the other (whether directly or indirectly and whether by ownership of share capital, the possession of voting power, contract or otherwise) has the power to appoint and/or remove all or the majority of the members of the Board of Directors or other governing body of that company or otherwise controls or has the power to control the affairs and policies of that company.

#### 4. **INTEREST AND OTHER CALCULATIONS**

(a) **Definitions:**

In these Conditions, unless the context otherwise requires, the following defined terms shall have the meanings set out below:

"**Business Day**" means:

- (i) a day other than a Saturday or Sunday on which the NBB-SSS is operating;
- (ii) a day on which banks and foreign exchange markets are open for general business in Belgium; and
- (iii) if a payment is to be made on that day, a day which is a business day for the TARGET System.

"**Day Count Fraction**" means, in respect of the calculation of an amount of interest on any Bond for any period of time (from and including the first day of such period to but excluding the last), the actual number of days in the Interest Period (as defined below) divided by 365 (or, if any portion of that Interest Period falls in a leap year, the sum of (i) the actual number of days in that portion of the Interest Period falling in a leap year divided by 366 and (ii) the actual number of days in that portion of the Interest Period falling in a non-leap year divided by 365).

"**interest**" shall be deemed to include all Interest Amounts and all other amounts payable pursuant to this Condition 4.

"**principal**" shall be deemed to include any premium payable in respect of the Bonds (including any Change of Control Put Redemption Amount) and all other amounts in the nature of principal payable pursuant to Condition 5 (*Redemption and purchase*) to it and all other amounts payable pursuant to this Condition 4.

"**Relevant Date**" means, in respect of any Bond, whichever is the later of (i) the date on which payment in respect of it first becomes due or (ii) (if any amount of the money payable is improperly withheld or refused) the date on which payment in full of the amount outstanding is made or (if earlier) the date seven calendar days after that on which notice is duly given to the Bondholders in accordance with Condition 13 (*Notices*) that such payment will be made, **provided that** such payment is in fact made as provided in these Conditions.

"**TARGET System**" means the Trans-European Automated Real-Time Gross Settlement Express Transfer (TARGET2) System or any successor thereto.

(b) **Applicable Rate of Interest:**

Each Bond bears interest on its outstanding nominal amount from (and including) the date on which the Bonds have been issued (the "**Issue Date**") at the rate of 2.000 per cent per annum (the "**Rate of Interest**").

Interest is payable in arrear on 23 June in each year (each an "**Interest Payment Date**"), commencing with the first Interest Payment Date falling on 23 June 2018.

Interest shall be calculated for the first period beginning on (and including) the Issue Date and ending on (but excluding) the first Interest Payment Date and for each successive period beginning on (and including) an Interest Payment Date and ending on (but excluding) the next succeeding Interest Payment Date (each an "**Interest Period**").

The amount of interest payable for each Bond for any Interest Period shall be equal to the product of (1) the Rate of Interest, (2) the outstanding nominal amount of the Bond and (3) the Day Count Fraction (the "**Interest Amount**").

(c) **Accrual of Interest:**

Interest shall cease to accrue on each Bond on the due date for redemption unless payment is improperly withheld or refused, in which event interest shall continue to accrue (as well after as before judgement) at the Rate of Interest in the manner provided in this Condition 4 (*Interest and other Calculations*) to the Relevant Date.

(d) **Rounding:**

For the purposes of any calculations required pursuant to these Conditions (unless otherwise specified), (1) all percentages resulting from such calculations shall be rounded, if necessary, to the nearest one hundred-thousandth of a percentage point (with halves being rounded up), (2) all figures shall be rounded to seven significant figures (with halves being rounded up) and (3) all currency amounts that fall due and payable shall be rounded to the nearest unit of such currency (with halves being rounded up). For these purposes, "**unit**" means the lowest amount of such currency that is available as legal tender in the country(ies) of such currency.

(e) **Calculation Agent:**

The Issuer shall procure that there shall at all times be one or more Calculation Agents for so long as any Bond is outstanding (as defined in the Agency Agreement).

Where more than one Calculation Agent is appointed in respect of the Bonds, references in these Conditions to the Calculation Agent shall be construed as each Calculation Agent performing its respective duties under the Conditions.

If the Calculation Agent is unable or unwilling to act as such or if the Calculation Agent fails to calculate any Interest Amount or Change of Control Put Redemption Amount, as the case may be, or to comply with any other requirement, the Issuer shall appoint a leading bank or investment banking firm engaged in the interbank market that is most closely connected with the calculation or determination to be made by the Calculation Agent (acting through its principal office or any other office actively involved in such market) to act as such in its place.

The Calculation Agent may not resign its duties without a successor having been appointed as aforesaid.

5. **REDEMPTION AND PURCHASE**

(a) **Final Redemption:**

Unless previously redeemed, purchased and cancelled as provided below, each Bond will be redeemed at 100 per cent of the Specified Denomination on 23 June 2025 (the "**Maturity Date**"). The Bonds may only be redeemed at the option of the Bondholders prior to the Maturity Date in accordance with Condition 5 (b) (*Redemption at the option of the Bondholders following a Change of Control*).

(b) **Redemption at the option of the Bondholders following a Change of Control:**

(i) **Definitions:**

"**Change of Control**" means a situation where an entity, other than a Public Entity, acquires, directly or indirectly, more than 50% of the shares in the Issuer, or more than 50% of the shares in any Guarantor in each case, save to the extent approved in advance by a resolution of the meeting of the Bondholders.

"**Change of Control Put Date**" means the fourteenth (14) Business Day after the expiry of the Change of Control Put Exercise Period.

"**Change of Control Put Exercise Period**" means the period commencing on the date of a Change of Control and ending fifteen (15) calendar days following the Change of Control, or, if later, fifteen (15) calendar days following the date on which a Change of Control Notice is given to Bondholders as required by Condition 5 (b) (iii).

"**Change of Control Put Redemption Amount**" means in respect of each Bond, an amount per Bond calculated by the Calculation Agent, with a minimum equal to the principal amount of such Bond, by multiplying the Redemption Rate by the Specified Denomination of such Bond and rounding, if necessary, the resultant figure to the nearest minimum sub-unit of euro (half of such unit being rounded downwards), and by adding any accrued but unpaid interest of such Bond to (but excluding) the relevant redemption date, where:

"**Redemption Rate**" means  $\text{MIN} (101\%; 100\% \times \text{Exp} (T \times 0.74720148386\%))$ , rounded down to the 9th decimal.

"**T**" means the time, expressed in decimals of a year, elapsed from (and including) the Issue Date until (and including) the relevant redemption date.

For the avoidance of doubt, "**Exp**" means the exponential function meaning the function  $e^x$ , where  $e$  is the number (approximately 2.718) such that the function  $e^x$  equals its own derivative.

*The Change of Control Put Redemption Amount applicable in the case of, or following, a Change of Control referred to under Condition 5(b) (Redemption at the Option of Bondholders following a Change of Control), reflects a maximum yield of 0.75 points above the yield of each of the Bonds on the Issue Date up to the Maturity Date in accordance with the Royal decree of 26 May 1994 on the deduction of withholding tax (Koninklijk Besluit van 26 mei 1994 over de inhouding en de vergoeding van de roerende voorheffing / Arrêté royal de 26 mai 1994 relatif à la perception et à la bonification du précompte mobilier conformément). This Royal Decree requires that in relation to Bonds which can be traded on N-accounts, if investors exercise a right to have the Bonds redeemed early, the actuarial return cannot exceed the actuarial return of the Bonds upon the issue up to the final maturity, by more than 0.75 points.*

"**Public Entity**" means any public authority (including any *intergemeentelijk samenwerkingsverband/ association intercommunale*, but only to the extent

such *intergemeentelijk samenwerkingsverband/ association intercommunale* is controlled (within the meaning of article 5 of the Belgian Companies Code) by municipalities (*gemeenten/communes*)), or federal, regional or provincial government in Belgium, or any public agency of such public authority or federal, regional or provincial government.

(ii) ***Exercise of put option:***

Each Bondholder will, in the event that a Change of Control occurs, have the right to require the Issuer to redeem the Bonds it holds on the Change of Control Put Date at the Change of Control Put Redemption Amount.

To exercise such right, the relevant Bondholder must, at any time during the Change of Control Put Exercise Period, complete and deliver or deposit with the financial intermediary through which it holds the Bonds (the "**Financial Intermediary**") for further delivery to the Issuer (with a copy to the Specified Office of the Agent) a duly completed put option notice in the form for the time being obtainable from the Agent (a "**Change of Control Put Exercise Notice**"). By delivering a Change of Control Put Exercise Notice, the Bondholder shall undertake to hold its Bond up to the Change of Control Put Date. Upon receipt of such Change of Control Put Exercise Notice, the relevant Financial Intermediary shall deliver a duly completed receipt for such Change of Control Put Exercise Notice (a "**Put Exercise Receipt**") to the depositing Bondholder and provide a copy of the Change of Control Put Exercise Notice to the Issuer.

Bondholders should check when the relevant Financial Intermediary should receive the Change of Control Put Exercise Notice from the Bondholder in order to meet the deadline for such exercise to be effective.

The Issuer will not be liable for any action, inaction or late action of the Financial Intermediary or the Agent and any fees charged by the Financial Intermediary and/or the Agent in relation to the deposit of the Change of Control Put Exercise Notices or the transfer of the relevant Bonds will be borne by the relevant Bondholder.

Payment in respect of any such Bond shall be made by transfer to a euro account maintained with a bank in a city in which banks have access to the TARGET System as specified by the relevant Bondholder in the relevant Change of Control Put Exercise Notice.

A Change of Control Put Exercise Notice, once delivered, shall be irrevocable and the Issuer shall redeem all Bonds which are the subject of Change of Control Put Exercise Notices delivered as specified above on the Change of Control Put Date.

If, prior to the Change of Control Put Date, an Event of Default occurs in respect of such Bond or if the payment of the Change of Control Put Redemption Amount is improperly withheld or refused, to the extent that any Bonds have been transferred to the the Agent, the Agent shall, without prejudice to the right of the Bondholder to request redemption in accordance with the Conditions, retransfer such Bond to the relevant Bondholder on the securities account as specified in the relevant Change of Control Put Exercise Notice.

The Agent shall not be required to monitor or take any steps to ascertain whether a Change of Control or any event which could lead to a Change of Control has occurred or may occur and will not be responsible or liable to Bondholders or any other person for any loss arising from any failure by it to do so.

(iii) **Change of Control Notice:**

Within fifteen (15) calendar days following a Change of Control, the Issuer shall give notice thereof to the Bondholders in accordance with Condition 13 (*Notices*) (a "**Change of Control Notice**"). The Change of Control Notice shall be irrevocable. The Change of Control Notice shall contain a statement informing Bondholders of their entitlement to exercise their rights to require redemption of their Bonds at their nominal amount pursuant to Condition 5 (b) (ii).

The Change of Control Notice shall also specify:

- (A) the nature of the Change of Control;
- (B) the last day of the Change of Control Put Exercise Period;
- (C) the Change of Control Put Date; and
- (D) the Change of Control Put Redemption Amount.

(c) **Purchases:**

Subject to the requirements (if any) of any stock exchange on which the Bonds may be admitted to listing and trading at the relevant time and subject to compliance with applicable laws and regulations, the Issuer may at any time purchase Bonds in the open market or otherwise at any price. Voting rights attached to such repurchased Bonds shall be suspended in the event of a general meeting of Bondholders and such Bonds shall also be deemed not to remain outstanding for this purpose.

(d) **Cancellation:**

All Bonds so redeemed or purchased by or on behalf of the Issuer under this Condition 5 will forthwith be cancelled. Any Bonds so cancelled may not be reissued or resold and the obligations of the Issuer in respect of any such Bonds pursuant to these Conditions shall be discharged.

6. **PAYMENTS**

(a) **Payments:**

All payments of principal or interest owing under the Bonds shall be made through the Domiciliary Agent and the NBB-SSS in accordance with the Securities Settlement System Regulations and the Clearing Services Agreement. The payment obligations of the Issuer will be discharged to the extent of any payment made by it to the NBB.

(b) **Payment subject to fiscal laws:**

All payments in respect of the Bonds will be subject in all cases to any fiscal or other laws and regulations applicable thereto in the place of payment.

(c) **Appointment of Agents:**

The Domiciliary Agent, the Paying Agent and the Calculation Agent(s) act solely as agent of the Issuer and do not assume any obligations towards or relationship of agency with any of the Bondholders.

The Issuer reserves the right at any time to vary or terminate the appointment of the Domiciliary Agent, the Paying Agent and/or the Calculation Agent(s), **provided however that** the Issuer shall at all times maintain (i) a Domiciliary Agent in the NBB-SSS, (ii) one or more calculation Agents where the Conditions so require and (iii) a Paying Agent in Belgium so long as any Bonds are listed on Euronext Brussels.

Notice of any such change shall promptly be given to the Bondholders in accordance with Condition 13 (*Notices*).

(d) **Non-Business Days:**

If any date for payment in respect of any Bond is not a Business Day, the Bondholder shall not be entitled to payment until the next following Business Day nor to any interest or other sum in respect of such postponed payment. For the purpose of calculating the Interest Amount payable under the Bonds, the Interest Payment Date shall not be adjusted.

7. **TAXATION**

All payments of principal and interest by or on behalf of the Issuer in respect of the Bonds shall be made without withholding or deduction for, or on account of, any present or future taxes, duties, assessments or governmental charges of whatever nature ("**Taxes**") imposed, levied, collected, withheld or assessed by or on behalf of Belgium, or any political subdivision or any authority therein or thereof having power to tax, unless such withholding or deduction of the Taxes is required by law. The Issuer is not required to gross up the net payments received by a Bondholder in relation to the Bonds with the amounts withheld or deducted for tax purposes.

8. **PRESCRIPTION**

Claims against the Issuer for payment in respect of the Bonds shall be prescribed and become void unless made within ten years (in the case of principal (or any other amount (other than interest) payable in respect of the Bonds) or five years (in the case of interest) from the appropriate Relevant Date in respect of them.

9. **EVENTS OF DEFAULT**

If any of the following events ("**Events of Default**") occurs:

- (a) **Non-Payment:** the Issuer fails to pay the principal of or premium or interest on any of the Bonds when due and such failure continues for a period of seven calendar days in the case of principal or premium and fourteen calendar days in the case of interest; or
- (b) **Breach of Other Obligations:** the Issuer does not perform or comply with any one or more of its other covenants, agreements, undertakings or other obligations under or in respect of the Bonds which default is incapable of remedy or, if capable of remedy, is not remedied within 20 Business Days after notice of such default has been given to the Issuer by any Bondholder; or
- (c) **Cross-Default:** (i) any other present or future indebtedness of the Issuer or any Guarantor for or in respect of moneys borrowed or raised being declared due and payable prior to its stated maturity by reason of any event of default (however described), or (ii) any such indebtedness is not paid when due or, as the case may be, within any applicable grace period, or within five Business Days of becoming due if a longer grace period is not applicable or (iii) the Issuer or any Guarantor fails to pay when due or, as the case may be, within any applicable grace period or within five Business Days if a longer grace period is not applicable, any amount payable by it under any present or future guarantee for, or indemnity in respect of, any moneys borrowed or raised, **provided that** none of the events mentioned above in this paragraph (c) shall give rise to an Event of Default if the aggregate amount of the relevant indebtedness, guarantees and indemnities is less than EUR 25,000,000 or its equivalent in any other currency (on the basis of the middle spot rate for the relevant currency against the Euro as quoted by any leading bank on the day on which this paragraph operates); or
- (d) **Security Enforced:** any mortgage, charge, pledge, lien or other encumbrance, present or future, created or assumed by the Issuer in respect of any of its property or assets for an amount at the relevant time of at least EUR 25,000,000 or its equivalent in any other currency (on the basis of the middle spot rate for the relevant currency against the Euro as quoted by any leading bank on the day on which this paragraph operates) becomes

enforceable and any step is taken to enforce it (including the taking of possession or the appointment of a receiver, manager or other similar person); or

- (e) **Insolvency:** the Issuer is declared bankrupt or unable to pay its debts as they fall due, stops, suspends or announces its intention to stop or suspend payment of all or, a material part of (or of a particular type of) its debts or makes any agreement for the deferral, rescheduling or other readjustment of all of (or all of a particular type of) its debts (or any particular debt, in each case which it will or might otherwise be unable to pay when due), proposes or makes a general assignment or an arrangement or composition with or for the benefit of the relevant creditors in respect of any of such debts or a moratorium is declared or comes into effect in respect of all or any part of (or of a particular type of) the debts of the Issuer or any of its Subsidiaries; or
- (f) **Winding-up:** an order is made or an effective resolution passed for the winding-up or dissolution of the Issuer or any of the Guarantors or the Issuer or any of the Guarantors ceases or threatens to cease to carry on all or substantially all of its business or operations, except for the purpose of and followed by a reconstruction, amalgamation, reorganisation, merger, consolidation or solvent reorganisation that does not involve a reduction of the number of EAN-codes in respect of which the Issuer (or, provided that the successor of the Issuer is a Permitted Successor Entity, such Permitted Successor Entity) is the manager in excess of 10 per cent. of the amount of EAN-codes managed by the Issuer on the date of the Prospectus; or
- (g) **Electricity and gas distribution:** the Issuer ceases to be the operating company (werkmaatschappij) of the electricity and gas distribution system operators (DSOs) in the designated areas in Flanders or undergoes a reorganisation whereby its tasks in relation to the management of the electricity and gas grids are transferred to a third party or any of the Guarantors loses its licence of DSO in the designated areas in Flanders or undergoes a reorganisation whereby its tasks in relation to the electricity and gas grids are transferred to a third party, provided that no Event of Default shall arise under this paragraph (g) in case (i) the successor of the Issuer as the operating company of the Guarantors is a Permitted Successor Entity and proviso (ii) is satisfied, or (ii) the number of EAN-codes in the designated area in respect of which the Issuer or a Permitted Successor Entity ceases to be the operating company represents 10 per cent. or less of the aggregate number of EAN-codes in the whole of the designated area covered by the Issuer on the date of the Prospectus; or
- (h) **Guarantee:** any of the Guarantees ceases to be valid, enforceable or in full force and effect; or
- (i) **Authorisation and Consents:** any action, condition or thing (including the obtaining or effecting of any necessary consent, approval, authorisation, exemption, filing, licence, order, recording or registration) at any time required to be taken, fulfilled or done in order to (i) enable the Issuer lawfully to enter into, exercise its rights and perform and comply with its obligations under the Bonds, (ii) ensure that those obligations are legally binding and enforceable and (iii) make the Bonds admissible in evidence in the courts of Belgium is not taken, fulfilled or done; or
- (j) **Illegality:** it is or will become unlawful for the Issuer to perform or comply with any or more of its obligations under the Bonds; or
- (k) **Suspension of trading or listing:** the listing or admission to trading of the Bonds on the regulated market of Euronext Brussels is withdrawn or suspended for a period of at least 15 subsequent Business Days as a result of a failure of the Issuer, unless the Issuer obtains the listing of the Bonds on another regulated market of the European Economic Area at the latest on the last day of this period of 60 Business Days,

then any Bond may, by notice in writing given to the Issuer and to the Domiciliary Agent at its specified office by the Bondholder, be declared immediately due and payable at 100% of its Specified Denomination together with accrued interest (if any) until the date fixed for redemption

without further formality unless such Event of Default shall have been remedied prior to the receipt of such notice by the Domiciliary Agent.

For purposes of this Clause 9 (*Events of Default*), a "**Permitted Successor Entity**" means an entity succeeding the Issuer as the operating company (*werkmaatschappij*) for the Guarantors as electricity and gas distribution system operators, created pursuant to a merger or other corporate restructuring, which assumes all rights and obligations of the Issuer in respect of the Bonds, and in which the Guarantors hold upon the completion of such merger or other corporate restructuring directly or indirectly 60% or more of the share capital.

#### 10. **MEETING OF BONDHOLDERS AND MODIFICATIONS**

##### (a) **Meetings of Bondholders:**

The articles of association of the Issuer contain provisions for convening meetings of Bondholders to consider matters affecting their interests.

All meetings of Bondholders will be held in accordance with the provisions of the articles of association of the Issuer. The articles of association of the Issuer require, in order for the meeting to be able to validly deliberate, that Bondholders which represent at least 50 per cent. of the outstanding amount of the Bonds are present or validly represented. If this quorum is not met, a convening notice for a new meeting shall be issued within one month. The newly adjourned meeting shall deliberate and decide regardless of the amount of Bonds presented or represented. The meeting of Bondholders shall be entitled to exercise the powers set out in the articles of association of the Issuer and, where applicable upon a proposal of the board of directors of the Issuer, to modify or waive any provision of these Conditions, which includes the proposal to (i) change any date fixed for payment of principal or interest in respect of the Bonds, to reduce the amount of principal or interest payable on any date in respect of the Bonds or to alter the method of calculating the amount of any payment in respect of the Bonds on redemption or maturity or the date for any such payment, (ii) effect the exchange, conversion or substitution of the Bonds for, or the conversion of the Bonds into, shares, bonds or other obligations or securities of the Issuer or any other person or body corporate formed or to be formed and (iii) change the currency in which amounts due in respect of the Bonds are payable. The general meeting of bondholders decides with at least three quarters of the votes that were validly made. Each Bond has one vote.

The general meeting of Bondholders can be convened by the board of directors of the Issuer. The board of directors of the Issuer is required to convene a general meeting of Bondholders at the request of Bondholders representing at least 20% of the existing Bonds.

Convening notices for the general meeting of Bondholders will include an agenda setting out the matters to be considered during the meeting and the proposed decisions, and will be published in the Belgian State Gazette as well as in one Dutch speaking and one French speaking newspaper with wide circulation in Belgium, in each case at least fifteen business days prior to the meeting.

Resolutions duly passed in accordance with these provisions shall be binding on all Bondholders, whether or not they are present at the meeting and whether or not they vote in favour of such a resolution.

Bondholders do not have the right to attend the shareholders meeting of the Issuer.

##### (b) **Modification of Agency Agreement:**

The Issuer shall only permit any modification of, or any waiver or authorisation of any breach or proposed breach of or any failure to comply with, the Agency Agreement and/or the Clearing Services Agreement, if to do so could not reasonably be expected to be materially prejudicial to the interests of the Bondholders or which in the Agent's opinion is of a formal, minor or technical nature or is made to correct a manifest error to comply with mandatory provisions of law.



11. **FURTHER ISSUES**

The Issuer may from time to time without the consent of the Bondholders create and issue further notes having the same terms and conditions as the Bonds (so that, for the avoidance of doubt, references in the conditions of such bonds to "**Issue Date**" shall be to the first issue date of the Bonds) and so that the same shall be consolidated and form a single series with such Bonds, and references in these Conditions to "**Bonds**" shall be construed accordingly.

12. **NOTICES**

Notices to Bondholders shall be valid (i) if published on the website of the Issuer (currently www.eandis.be), (ii) published through the usual newswires agency (or any of the usual newswires agencies) used by the Issuer to discharge its ongoing information duties pursuant to the Royal Decree of 14 November 2007 and (iii) delivered to the National Bank of Belgium for communication to the Bondholders via participants to the NBB-SSS. The Issuer shall also ensure that all notices are duly published in a manner which complies with the rules and regulations of any stock exchange on which the Bonds are listed for the time being, and in the case of a convening notice for a meeting of Bondholders, in accordance with the articles of association of the Issuer. Any such notice shall be deemed to have been given on the date of such publication or, if published more than once or on different dates, on the first date on which publication is made, as provided above. The costs relating to the publication of the notices to Bondholders shall be borne by the Issuer.

Notices to be given by any Bondholder shall be in writing and given by lodging the same with the Domiciliary Agent or the Paying Agent.

13. **CURRENCY INDEMNITY**

Any amount received or recovered in a currency other than the currency in which payment under the relevant Bond is due (whether as a result of, or of the enforcement of, a judgement or order of a court of any jurisdiction, in the winding-up or dissolution of the Issuer or otherwise) by any Bondholder in respect of any sum expressed to be due to it from the Issuer shall only constitute a discharge to the Issuer, as the case may be, to the extent of the amount in the currency of payment under the relevant Bond that the recipient is able to purchase with the amount so received or recovered in that other currency on the date of that receipt or recovery (or, if it is not practicable to make that purchase on that date, on the first date on which it is practicable to do so). If the amount received or recovered is less than the amount expressed to be due to the recipient under any Bond, the Issuer shall indemnify it against any loss sustained by it as a result. In any event, the Issuer shall indemnify the recipient against the cost of making any such purchase. For the purposes of this Condition 14, it shall be sufficient for the Bondholder to demonstrate that it would have suffered a loss had an actual purchase been made. These indemnities constitute a separate and independent obligation from the Issuer's other obligations, shall give rise to a separate and independent cause of action, shall apply irrespective of any indulgence granted by any Bondholder and shall continue in full force and effect despite any other judgement, order, claim or proof for a liquidated amount in respect of any sum due under any Bond or any other judgement or order.

14. **GOVERNING LAW, JURISDICTION, WAIVER OF IMMUNITY, DIRECT RIGHTS**

(a) **Governing Law:**

The Bonds and any non-contractual obligations arising out of or in connection with the Bonds are governed by, and shall be construed in accordance with, Belgian law.

(b) **Jurisdiction:**

The Courts of Brussels, Belgium are to have exclusive jurisdiction to settle any disputes which may arise out of or in connection with the Bonds and, accordingly, any legal action or proceedings arising out of or in connection with the Bonds ("**Proceedings**") may be brought in such courts. The Issuer and the Guarantors irrevocably submit to the jurisdiction of such courts and waive any objection to Proceedings in such courts

whether on the ground of venue or on the ground that the Proceedings have been brought in an inconvenient forum.

(c) **Waiver of immunity:**

The Issuer and the Guarantors hereby irrevocably and unconditionally to the fullest extent possible waive with respect to the Bonds any right to claim sovereign or other immunity from jurisdiction or execution and any similar defence and irrevocably and unconditionally consent, to the fullest extent possible, to the giving of any relief or the issue of any process, including without limitation, the making, enforcement or execution against any property whatsoever (irrespective of its use or intended use) of any order or judgement made or given in connection with any suit, action or proceeding.

(d) **Direct Rights:**

To the extent necessary, the Issuer grants to each Bondholder the right to claim directly against the Issuer in the event of insolvency of the Issuer and to exercise their associative rights (including the exercise of any vote in the general meeting of Bondholders) directly with the Issuer, in accordance with articles 12 and 13 of the Coordinated Belgian Royal Decree Number 62 of 10 November 1967 relating to the deposit of fungible financial instruments and the settlement of transactions in these instruments (*Gecoördineerd koninklijk besluit 62 betreffende de bewaargeving van vervangbare financiële instrumenten en de vereffening van transacties op deze instrumenten/Arrêté royal coordonné 62 relatif au dépôt d'instruments financiers fongibles et à la liquidation d'opérations sur ces instruments*).

## PART V – SETTLEMENT

The Bonds will be accepted for clearance through the NBB-SSS under the ISIN number BE0002285543 and Common Code 162910965 with respect to the Bonds and will accordingly be subject to the Securities Settlement System Regulations.

The number of Bonds in circulation at any time will be registered in the register of registered securities of the Issuer in the name of the NBB (National Bank of Belgium, Boulevard de Berlaimont 14, 1000 Brussels, Belgium).

Access to the NBB-SSS is available through the NBB-SSS participants whose membership extends to securities such as the Bonds.

NBB-SSS participants include certain banks, stockbrokers (*beursvennootschappen/ sociétés de bourse*), Euroclear and Clearstream, Luxembourg. Accordingly, the Bonds will be eligible for clearance through Euroclear and Clearstream, Luxembourg, and investors can hold their Bonds within securities accounts in Euroclear, and Clearstream, Luxembourg.

Transfers of interests in the Bonds will be effected between NBB-SSS participants in accordance with the rules and operating procedures of the NBB-SSS. Transfers between investors will be effected in accordance with the respective rules and operating procedures of the NBB-SSS participants through which they hold their Bonds.

Belfius Bank NV/SA will perform the obligations of domiciliary agent included in the Agency Agreement and of paying agent included in the clearing services agreement dated on or about 6 June 2017 by the NBB, the Issuer and the Agent (the "**Clearing Services Agreement**"). The Issuer and the Agent will not have any responsibility for the proper performance of the NBB-SSS or the NBB-SSS participants of their obligations under their respective rules and operating procedures.

## PART VI – FORM OF THE GUARANTEE

### Abstract and Non-Accessory Guarantee of [•]

For the benefit of: Any investor holding directly or indirectly any of the 2.000 per cent fixed rate bonds due 23 June 2025 (the "**Bonds**") (each a "**Bondholder**")

Date: 6 June 2017

In consideration of:

- Eandis System Operator CVBA acting as issuer of the Bonds (the "**Issuer**"); and
- the Issuer, each of Gaselwest, IMEA, Imewo, Intergem, Iveka, Iverlek and Sibelgas as guarantors and Belfius Bank NV/SA and BNP Paribas Fortis NV/SA as joint lead managers entering into a placement agreement dated 6 June 2017 (the "**Placement Agreement**").

Terms defined in the terms and conditions of the Bonds (the "**Conditions**") shall, insofar as the context so admits, have the same meaning when used herein.

[•], a mission entrusted entity (*opdrachthoudende vereniging*) established under the laws of Belgium, having its registered office at [•] and registered with the Crossroads Bank for Enterprises (*Kruispuntbank van Ondernemingen/Banque-Carrefour des Entreprises*) under number [•] (the "**Guarantor**") unconditionally and irrevocably guarantees to each Bondholder the due and punctual payment and performance of the Proportional Share (as defined below) of all moneys, obligations and liabilities owed or incurred by the Issuer to the Bondholders in respect of the Bonds, whether actual, future or contingent and whether or not the Bondholder has acquired the Bond on the Issue Date or at a later stage, in accordance with the Conditions of the Bonds on the date specified for such payment (whether on the normal due date, on acceleration or otherwise) (the "**Guarantee**") upon the following terms:

- (i) in the event of any failure by the Issuer to pay duly and punctually any such principal, interest or other amount, the Guarantor agrees to cause each and every such payment to be made as if the Guarantor instead of the Issuer were expressed to be the primary obligor of the Bonds to the intent that the Bondholder shall receive the same amounts in respect of principal, interest or such other amount as would have been receivable had such payments been made by the Issuer;
- (ii) the Guarantor agrees that its obligations under this Guarantee shall be abstract, non-accessory, independent, unconditional and irrevocable and on a first demand basis without raising any objections of whatever nature arising out of the underlying obligation of the Issuer relating to the Bonds, irrespective of the absence of any action to enforce the same, the recovery of any judgment against the Issuer or of any action to enforce the same or any other circumstance relating to the underlying Bond which might otherwise constitute a discharge or defence of a guarantor, it being understood that no demand shall be accepted in the event that all principal, interest or other amount due under the Bonds has been punctually made by the Issuer;
- (iii) the Guarantor agrees that nothing in this Guarantee must be construed so that this Guarantee would constitute a surety (*borgtocht/cautionnement*) and that nothing in this Guarantee will affect its intention to grant an independent and abstract guarantee pursuant to this Guarantee and not a surety (*borgtocht/cautionnement*);
- (iv) the Guarantor confirms that its obligations under this Guarantee in respect of the Bonds shall, at all times, be limited to the proportional share it holds in the share capital of the Issuer, as of the date of the issue of the Bonds, as set out in the Conditions (the "**Proportional Share**");
- (v) the Guarantor confirms with respect to each Bond that it does not have, and will not assert as a defence to any claim hereunder, any right to require any proceedings first against the Issuer, nor will it assert as a defence to any claim hereunder any lack of diligence, presentment to the Issuer or the Agent and any demand for payment from the Issuer or the Agent, any filing of claims with any court in the event of merger, insolvency or bankruptcy of the Issuer, any protest, notice or any other demand whatsoever (other than a demand for payment of this Guarantee in compliance with the terms hereof) and the Guarantor confirms that this Guarantee will not be discharged except by complete performance of the obligations contained in each Bond and in this Guarantee;

- (vi) this Guarantee constitutes an abstract, non-accessory, independent, direct, unconditional, irrevocable, first demand, unsubordinated and unsecured obligation of the Guarantor and ranks *pari passu* (subject to mandatorily preferred debts under applicable laws), equally and rateably with all other present and future outstanding unsecured and unsubordinated obligations of the Guarantor;
- (vii) the Guarantor agrees that it shall comply with and be bound by those provisions contained in the Conditions of the Bonds, the Agency Agreement and the Placement Agreement which relate to it;
- (viii) the records of the settlement system operator shall, in the absence of manifest error, be conclusive evidence of the identity of the Bondholder, the number of entries credited to the securities account of such holder with such settlement system operator at the relevant time and the amounts represented by such entries, as set forth in the Conditions of the Bonds;
- (ix) the Guarantor represents and warrants (which representations and warranties shall be deemed to be repeated on each day that this Guarantee continues in force) that:
  - (a) the Guarantor is a mission entrusted entity (*opdrachthoudende vereniging*) (or in the case of a future change of the law, an equivalent or similar legal entity) with the power to enter into and to perform the obligations expressed to be assumed by it under the agreements to which it is expressed to be a party in connection with the issue of the Bonds. The Guarantor has the power to execute and deliver this Guarantee and to perform its obligations under this Guarantee and has taken all necessary action to authorise such execution and delivery and performance of such obligations;
  - (b) the Guarantor is aware of the representations made and warranties given by the Issuer under the Placement Agreement;
  - (c) this Guarantee constitutes the legal valid and binding obligations of the Guarantor duly enforceable in accordance with their terms; the Guarantor shall not in any circumstances challenge the legality, validity or enforceability of this Guarantee;
  - (d) the execution and performance of this Guarantee will not contravene any provision of any existing law, decree or regulation or of its constitutive documents or of any agreement to which it is a party;
  - (e) it is not engaged in or under threat of litigation nor is it in default in respect of any financial commitment which might in either case affect its ability to perform its obligations under this Guarantee; and
  - (f) all payments of principal and interest by or on behalf of the Guarantor in respect of any Bond while it is held by an eligible investor (as defined in article 4 of the Belgian Royal Decree of 26 May 1994 on the deduction of withholding tax, as in force on the date hereof) (an "**Eligible Investor**") shall be made free and clear of, and without withholding or deduction of, any taxes, duties, assessments or governmental charges of whatever nature imposed, levied, collected, withheld or assessed by or within Belgium or any authority therein or thereof having power to tax;
- (x) so long as any sum remains payable under the Bonds, if any moneys have been paid by the Guarantor under this Guarantee, the Guarantor shall suspend the execution of all its claims against the Issuer and shall not enforce any claim, security or other guarantee against the Issuer until all moneys due from the Issuer to the Bondholders have been paid in full. The Guarantor hereby irrevocably authorises and requires the Issuer and any liquidator of the Issuer to first pay the Bondholders any moneys due, before paying any moneys to the Guarantor;
- (xi) a demand or notice hereunder shall be in writing signed by a duly authorised officer, representative or agents of the Bondholder and specify name, address and bank account details of the relevant Bondholder and the number of Bonds such Bondholder owns. The demand or notice must be sent to the Guarantor by registered mail with a form for acknowledgement of receipt, at the following address:

[name Guarantor]  
p.a. Eandis System Operator CVBA  
Brusselsesteenweg 199  
9090 Melle  
Belgium  
Attention: Vennootschapssecretariaat

If a Bondholder fails to exercise or delays to exercise its rights under this Guarantee, this shall under no circumstances constitute a waiver of its rights. If a Bondholder partly exercises any rights regarding this Guarantee, this shall not prevent the future or further exercise of such rights or the exercise of any other rights by a Bondholder;

- (xii) in the case of any transfer or reorganisation permitted pursuant to paragraphs (f) and (g) of Condition 9 (*Events of Default*), the transferee shall assume the obligations of the transferor under this Guarantee;
- (xiii) references to the Bondholders, the Issuer and the Guarantor include their respective successors and assigns. References to persons include references to companies, corporations, firms, governments, states or state agencies, associations, and any other legal entities. Where the context so permits, the singular includes the plural and *vice versa*;
- (xiv) this Guarantee is governed by, and shall be construed in accordance with, the laws of Belgium. Claims against the Guarantor thereunder may be brought before the courts in Brussels, Belgium, which shall have exclusive competence; and
- (xv) the Guarantor hereby waives, to the fullest extent permitted by applicable law, with respect to itself and its revenues and assets (irrespective of their use or intended use), all immunity on the grounds of sovereignty or other similar grounds from (i) suit, (ii) jurisdiction of any court, (iii) relief by way of injunction, order for specific performance or for recovery of property, (iv) attachment of its assets (whether before or after judgment) and (v) execution or enforcement of any judgment to which it or its revenues or assets might otherwise be entitled in any proceedings in the courts of any jurisdiction and irrevocably agrees, to the extent permitted by applicable law, that it will not claim any such immunity in any proceedings.

This abstract and non-accessory Guarantee has been executed on [•] 2017.

.....  
Name:  
Title:

.....  
Name:  
Title:

PART VII – DESCRIPTION OF THE BELGIAN ELECTRICITY AND GAS MARKET

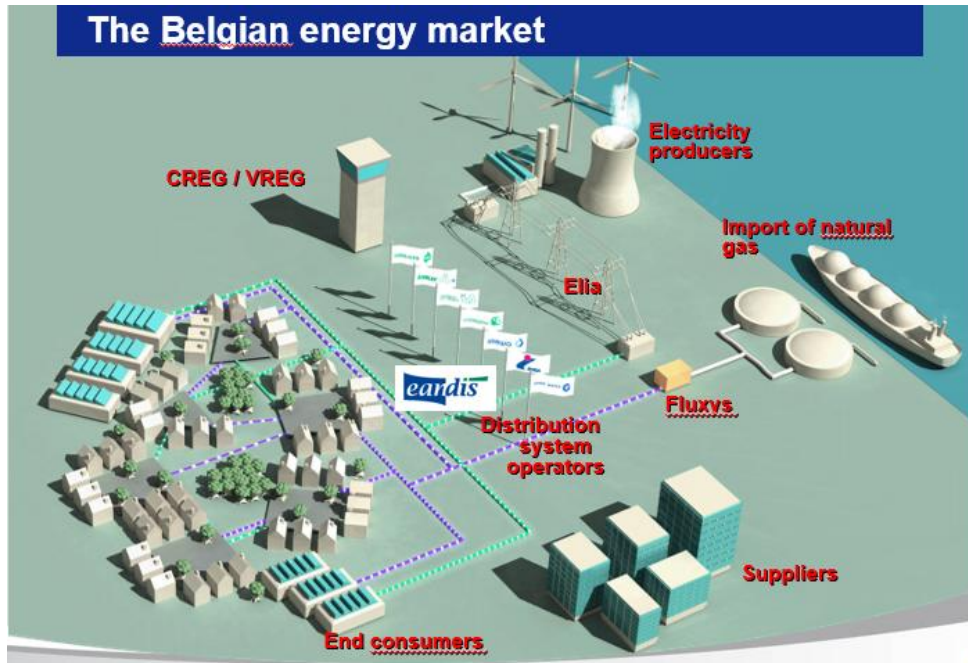

1. **Organisation of the Belgian Electricity Market**

The major players on the liberalised Flemish electricity market are the electricity producers, the transmission system operator ("TSO") and the distribution system operators ("DSOs"), the wholesale and retail suppliers, the end consumers and the regulators. Their functions are briefly outlined below. The Guarantors are DSOs in the Belgian electricity market.

The picture below sketches the Belgian electricity market.

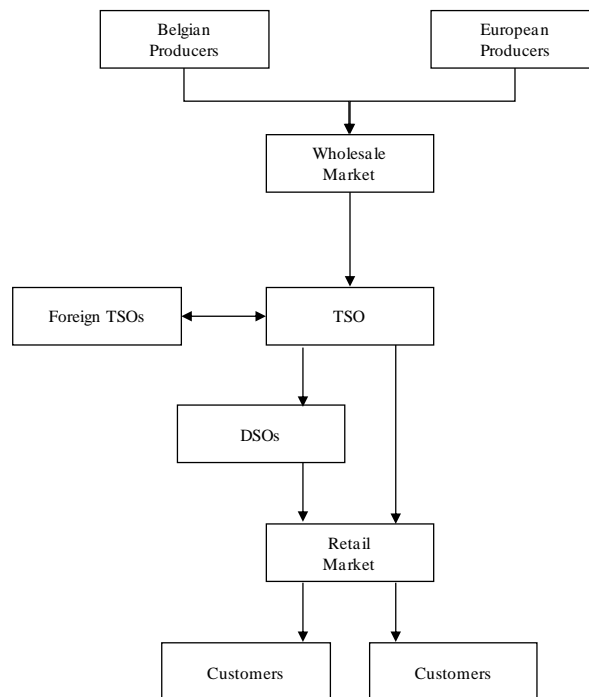

1.1 **Electricity Production**

Currently, the electricity generating market is divided in, on the one hand, a limited number of large-scale production units (nuclear and others) and, on the other hand, a large and growing

number of small-scale generation units. The latter typically include decentralised units of renewable energy production.

Building and operating new electricity generating facilities is open for each authorised electricity producer. Units with a generating capacity exceeding 25 MW need the approval of the federal Minister for Energy, who will decide after having received a prior advice by the federal energy regulator, the CREG ("*Commissie voor de Regulering van de Elektriciteit en het Gas*" / "*Commission de Régulation de l'Electricité et du Gaz*"). Smaller generating facilities (equal to or below 25 MW) are exempt from the prior individual licence, but some of them have to be notified to the CREG, the competent federal minister or his representative.

Over the years, the electricity producers have adapted their portfolio of primary energy sources for electricity generation. In the sixties coal and petroleum were the major primary combustibles. At the end of the seventies the use of petroleum declined after having reached a peak in 1973. Later the contribution of nuclear production started to form a substantial part of the production mix. The use of nuclear energy started in 1975. In the early eighties nuclear energy became more important (in 1986 already 67.2 per cent of electricity was generated through nuclear energy) together with gas and cogeneration units; this trend continued during the nineties (the average contribution of nuclear energy in the nineties amounted to 58 per cent - gas and combined production units accounted for 17 per cent). For a number of years now, the share of renewable energy sources has been increasing, mainly due to the use of wind turbines, solar installations and biomass. Eurostat figures published on 14 March 2017<sup>11</sup> show that the share of electricity generated from renewable sources in the gross electricity consumption in Belgium has increased to 7.9 per cent in 2015.

With a capacity of 5,920.8 MWh, nuclear plants produce around 50% of electricity in Belgium<sup>12</sup>. Whilst a law was passed in 2003 to limit the lifespan of the existing plants to 40 years, the federal government has taken steps in 2015 to prolong its dependency on nuclear energy and has granted ten-year extensions to the lifespan of its three oldest reactors, allowing the last one to continue functioning until 2025. In that year the use of nuclear power should be completely phased-out.

The EU's and the Belgian federal government's general energy policies aim at increasing the share of renewable energy generation and combined heat and power production (CHP). In order to stimulate these types of electricity production the federal government has taken legal initiatives enabling the construction of offshore wind farms on the basis of a renewable energy certificates scheme with the TSO Elia System Operator NV being required to purchase such certificates at minimum price upon request (in accordance with the Royal Decree of 16 July 2002 (as amended from time to time)). The regional governments have also worked out several measures to attain this goal equally on the basis of a renewable energy certificates scheme and a minimum price guarantee mechanism whereby the DSOs are responsible to buy certificates against a minimum price. The functioning of the renewable energy certificates systems in the Flemish region is further outlined in section 6.10 in "*Part IX – Description of the Issuer and the Guarantors*"; the working of the CHP-certificates system is almost identical. The Walloon and Brussels regions have taken very similar measures.

## 1.2 ***Key figures for electricity production in Belgium***

In general, technological evolutions result in an increasing number of smaller installations being put in place, continually increasing the share of decentralised and combined heat and power production.

Net electricity production in Belgium has been steadily decreasing from a peak in 2010 (91.5 TWh) to 65.5 TWh in 2015<sup>13</sup>. This corresponds to a 28.4% decrease in the period 2010-2015.

---

<sup>11</sup> Source: Eurostat newsrelease 43/2017, published 14 March 2017

<sup>12</sup> Source: [http://economie.fgov.be/nl/consument/Energie/Nucleaire/kerncentrales/Productiepark\\_kerncentrales/#](http://economie.fgov.be/nl/consument/Energie/Nucleaire/kerncentrales/Productiepark_kerncentrales/#). WRQevOmwfiU (consulted on 11 May 2017).

<sup>13</sup> source: [https://www.febeg.be/sites/default/files/febeg\\_annual\\_report\\_2015\\_nl.pdf](https://www.febeg.be/sites/default/files/febeg_annual_report_2015_nl.pdf) (consulted 11 May 2017)



The production of electricity from renewable sources has shown a remarkably increasing trend in the last decade. Partly as a consequence of new off-shore wind farms, wind and solar have become the most important source of renewable electricity production in Belgium. In 2015, wind generated 5.57 TWh and solar production amounts to 3.07 TWh<sup>14</sup>. The share of electricity generated in Belgium from renewable sources in the total electricity production increased from 1.7% in 2004 to 15.4% in 2015<sup>15</sup>.

*The figures below summarise the key figures for Belgium's electricity market.*

Net electricity production in Belgium (2015)<sup>16</sup>: total of 65.5 TWh, of which

• nuclear:	37.5%
• fossil fuels:	38.4%
• hydro (+ pumped hydro):	2.0%
• wind:	8.2%
• solar:	4.6%
• biomass/biogas/waste:	9.1%

Electricity exchanges with Belgium's neighbouring countries were as follows (2016)<sup>17</sup>:

• import:	14.6 TWh	(-38.2% compared to 2015)
• export:	8.5 TWh	(+211.5% compared to 2015)
• net import:	6.2 TWh	(-70.5% compared to 2015)

### 1.3 **Wholesale Market for Electricity**

Suppliers on the wholesale market (e.g. traders and intermediaries) buy, in Belgium and abroad, energy from electricity producers or other wholesale suppliers and/or sell energy to either other wholesale suppliers or retail suppliers. Since retail supply is an activity for which a licence is required (as opposed to trading), traders do not often sell electricity directly to end customers.

### 1.4 **Transmission System Operation**

Transmission refers to the transport of electricity over the high and very high voltage grids with a voltage of 30 kV or higher in Brussels and Wallonia and 36 kV or higher in Flanders. The major users of these grids are the electricity producers, electricity traders, DSOs (such as the Guarantors) and industrial consumers with a direct connection to the high voltage electricity transmission network.

A transmission system operator or TSO operates and manages its grids independently from electricity and gas producers, importers and suppliers. TSOs have to organize an objective, non-discriminatory and transparent access to their electricity network. Transmission system operation is a regulated activity that is usually granted a legal monopoly. To fulfil this objective efficiently,

<sup>14</sup> source: Energy Observatory 2015 ([http://economie.fgov.be/nl/binaries/kerncijfers\\_2015\\_energie\\_tcm325-282790.pdf](http://economie.fgov.be/nl/binaries/kerncijfers_2015_energie_tcm325-282790.pdf)) (consulted 11 May 2017)

<sup>15</sup> source: <http://ec.europa.eu/eurostat/tgm/table.do?tab=table&init=1&language=en&pcode=tsdcc330&plugin=1> (accessed May 2017)

<sup>16</sup> source: <https://www.febeg.be/statistiek-elektriciteit> (consulted on 11 May 2017)

<sup>17</sup> source: [http://www.elia.be/~media/files/Elia/PressReleases/2017/20170224\\_pressrelease\\_EN-FY-Results-Elia-Group-2016.pdf](http://www.elia.be/~media/files/Elia/PressReleases/2017/20170224_pressrelease_EN-FY-Results-Elia-Group-2016.pdf), page 6 (accessed May 2017)

TSOs are in charge of the operation, maintenance and development of their grid. They also provide the required ancillary services.

The very high voltage electricity networks are also used for the import and export of electricity between interconnected national grids and for purposes of mutual assistance between TSOs according to international standards set by ENTSO-E<sup>18</sup> operation rules. Belgium's very high voltage electricity network is connected to France, the Grand-Duchy of Luxembourg and the Netherlands. The construction work for an interconnector between Belgium and the UK is currently underway (the Nemo Link project). Also, in addition, the contracts have been signed for the construction of an interconnector between Belgium and Germany (the ALEGrO project).

Whereas the intermunicipal entities such as the Guarantors usually hold the legal monopoly to manage the electricity distribution network with a voltage level below 30/36 kV, Elia System Operator NV<sup>19</sup> operates the local/regional electricity grid with a voltage level between 30/36 kV and 70 kV that is normally not considered as a distribution network from a technical and tariff point of view<sup>20</sup>, but which is considered part of the electricity distribution network by Flemish regulation (although the local transmission system is distinguished from the low and medium voltage distribution system to allow for different operators). Elia System Operator NV has been granted a legal monopoly to operate the grid in the Flemish, the Walloon and the Brussels-Capital Regions.

By a Ministerial Resolution dated 13 September 2002, Elia System Operator NV was appointed as Belgium's sole electricity TSO for a renewable period of twenty years. In addition, on 6 December 2012, the CREG, the federal energy regulator, certified Elia System Operator NV as the electricity TSO in accordance with the 'fully ownership unbundled model. These TSO unbundling rules apply across sectors, so the electricity TSO must also be independent from gas suppliers and importers, and the gas TSO must be independent from electricity suppliers and producers.

#### 1.5 ***Distribution System Operation***

Distribution refers to the transmission of electricity over medium and low voltage electricity networks, generally below 30 kV (Brussels/Wallonia) or 36 kV (Flanders), to retail consumers (small and medium-sized enterprises and household customers) using electricity for their own use. An operator of such a network is called a distribution system operator or DSO. The Guarantors are DSOs. Following a decision by the Flemish energy regulator VREG of 5 July 2013, the licence of the DSOs Gaselwest, Imewo, Intergem, Iveka, Iverlek and Sibelgas has been expanded to the operation of electricity distribution grids up to 36 kV (formerly 30 kV). Due to historic reasons, the DSO IMEA already possessed a licence up to 70 kV.

A DSO operates, maintains and develops its network and is required by law to organize access to its network in an objective, non-discriminatory and transparent manner. Distribution system operation is a regulated activity that is usually granted a legal monopoly within the boundaries of the operating territory attributed to each DSO.

The main customers of the DSOs (and thus of the Guarantors) are wholesale suppliers and retail suppliers<sup>21</sup>.

---

<sup>18</sup> ENTSO-E is the 'European Network of Transmission System Operators for Electricity', an association of 42 TSOs from 35 European countries. It is the successor of a number of former associations, including UCTE (Union for the Coordination of the Transmission of Electricity) that operated in continental Europe.

<sup>19</sup> Elia System Operator NV has been appointed as local- regional transmission system operator for that purpose.

<sup>20</sup> The federal regulator CREG is competent for the approval of the tariffs which apply to this grid voltage level.

<sup>21</sup> A third type of customers are the retail users that, because of payment problems, have been dropped by commercial suppliers of electricity. Flemish regulation provides that the DSOs have in such instance an obligation to supply these customers with electricity.

At the moment there are 11 DSOs in Flanders engaged in the distribution of electricity<sup>22</sup>, 7 of which are the Guarantors. The Guarantors cover around 80 per cent of the Flemish Region, both in terms of the number of end customers as well as in geographical area.

DSOs in Flanders are allowed to use an operating company ("*werkmaatschappij*") to operate the grid in their name and for their account. As described in more detail below in section 2.3 of "*Part VIII – Regulatory Framework applicable to the Flemish DSOs*", the Guarantors have mandated Eandis System Operator as their operating company.

#### 1.6 **Retail Supply**

Retail supply of electricity refers to the sale of electricity to end customers. Several commercial suppliers are active in the Flemish supply market.

A licence is required to engage in retail supply. In the Flemish Region, such licence may only be granted by the VREG to individuals or companies that operate independently from the TSO and the DSOs and that comply with the criteria laid down by law, such as sufficient technical and financial capacity. A supply licence is also required to supply electricity to customers located in the Brussels Region and the Walloon Region. In Brussels and Wallonia, such licence is respectively granted by the Brussels Government and the CWaPE.

The suppliers with the largest market share in Flanders (as per 31 December 2016)<sup>23</sup> are: (1) Engie Electrabel (40.98%), (2) EDF Luminus (20.26%), (3) Eni (11.83%), (4) Essent (7.08%) and (5) Lampiris (4.84%).

#### 1.7 **Customers**

Pursuant to the Second Electricity Directive<sup>24</sup>, all customers are eligible to choose their electricity supplier. The chosen supplier must, in turn, be provided with a "**right of access**" to the relevant electricity network (being very high, high, medium or low voltage) to ensure that electricity is supplied from the producer to the relevant end customer.

#### 1.8 **Regulators in Belgium**

Due to the Belgian federal structure, there are currently four regulators for the electricity market:

The federal energy regulator, the CREG, is competent amongst other things for supervising the electricity market at a voltage higher than 70 kV and for advising on the licensing of energy generation facilities with a capacity higher than 25 MW. Tariff setting for the TSO (transmission tariffs) is also within the scope of the CREG's authority, irrespective of the voltage level of the electricity network.

Regional regulators are competent, amongst other things, for supervising the electricity market operations at a voltage equal to or below 70 kV and for renewable sources of energy, to establish the distribution tariff methodology and to approve the distribution tariff proposals submitted by the Flemish DSOs. As described in more detail below in section 3.1 of "*Part VIII – Regulatory Framework applicable to the Flemish DSOs*", the Guarantors as Flemish DSOs need to submit their tariff proposals to the Flemish regulator.

---

<sup>22</sup> Source: VREG website. The stated number of 11 DSOs does not take into account the situation in the municipality Voeren.

<sup>23</sup> Source: <http://www.creg.be/nl/consumenten/energiemarkt/marktaandelen-energieleveranciers> (consulted on 11 May 2017).

<sup>24</sup> Directive 2003/54/EC of the European Parliament and of the Council of 26 June 2003 concerning common rules for the internal market in electricity and repealing Directive 96/92/EC. This directive has been implemented in Belgium on 17 July 2008 (*Décret du 17 juillet 2008 modifiant le décret du 12 avril 2001 relatif à l'organisation du marché régional de l'électricité*), see <http://eur-lex.europa.eu/legal-content/EN/NIM/?uri=celex:32003L0054>.

The regional regulators in the Flemish, Walloon and Brussels-Capital Regions are respectively the VREG, CWaPE<sup>25</sup> and Brugel<sup>26</sup>.

## 2. Organisation of the Belgian Gas Market

### 2.1 *Import*

Belgium does not possess gas fields on its own territory. Therefore, all natural gas for consumption in Belgium has to be imported from abroad. Finding an optimal sourcing and diversification of gas supplying countries is an essential element in Belgium's energy policy.

Currently, natural gas for the Belgian market is being imported from several sources (figures for 2015<sup>27</sup>), the most important of which are:

1. The Netherlands (38.2 per cent): the Dutch gas fields are connected to Belgium via pipelines;
2. Norway (30.0 per cent): Norway is an important gas producer thanks to its oil and gas fields in the North Sea; Norwegian gas is delivered in the Zeebrugge hub, operated by Huberator NV, a subsidiary of Fluxys NV ("**Fluxys**") via pipelines;
3. Qatar (14.0 per cent): natural gas is shipped to Belgium in liquefied form (LNG or Liquefied Natural Gas) by high capacity LNG tanker ships, delivering the gas in the Zeebrugge harbour LNG terminal owned by Fluxys LNG NV, a subsidiary of Fluxys;
4. The United Kingdom (16.5 per cent);
5. Other (1.3 per cent)

### 2.2 *Wholesale*

Suppliers on the wholesale market (e.g. traders and intermediaries) buy natural gas abroad or on the international spot market. They then sell on these volumes to industrial customers, intermediaries, distribution companies and electricity producers. Since gas retail supply, very much like electricity retail supply, is an activity for which a licence is required (as opposed to trading), traders most often do not directly sell natural gas to end consumers.

### 2.3 *Transport System Operation*

Transport system operation refers to the regulated activity related to the high-pressure gas networks and the energy flows on these networks. The main users of these networks are the electricity producers, wholesale gas suppliers, gas traders, the DSOs and the large industrial users of gas.

Transport system operators or TSOs, such as Fluxys Belgium NV ("**Fluxys Belgium** ") in Belgium, operate their networks in complete independence from electricity and gas producers, importers and suppliers and are bound to organise an objective, non-discriminatory and transparent access to their gas network. Transport operations are regulated activities that are usually granted a legal monopoly. To fulfil this objective efficiently, TSOs are in charge of the operation, maintenance and development of their network and also provide required ancillary services such as pressure reduction, odourisation, balancing and storage facilities.

TSOs are not only responsible for the off take and redelivery of natural gas within Belgium for Belgian consumption, they also fulfil a crucial role in the transit of gas to and from border states

<sup>25</sup> Commission Wallonne pour l'Energie.

<sup>26</sup> *Reguleringscommissie voor Energie in het Brussels Hoofdstedelijk Gewest / Commission de Régulation pour l'Energie en Région de Bruxelles-Capitale.*

<sup>27</sup> source: Energy Observatory - Federal Public Service Economic Affairs ([http://economie.fgov.be/nl/binaries/kerncijfers\\_2015\\_energie\\_tcm325-282790.pdf](http://economie.fgov.be/nl/binaries/kerncijfers_2015_energie_tcm325-282790.pdf) (consulted 11 May 2017))

since redelivery points will often be connection points with the gas transportation networks of other national networks. This is especially true for Belgium, given its good connection to natural gas and LNG supplies and given its central position and multiple entry points linking the Belgian gas transportation grid to the grids of France, Germany, Southern Europe and the Netherlands.

It must be noted that the Belgian grid caters for two different types of natural gas: (1) high calorific natural gas and (2) low calorific natural gas (with this last type of gas being imported from the Netherlands). It is expected that the supplies of low calorific natural gas from the Netherlands might end within a few years' time. This necessitates investments, partly to be financed by the DSOs.

In Belgium, Fluxys Belgium was appointed on 23 February 2010 as the sole federal transport system operator for the gas transmission grid. The gas transport system operator is frequently referred to as the "**transport company**". In addition, on 27 September 2012, the CREG certified Fluxys Belgium as the gas TSO in accordance with the 'fully ownership unbundled' model. These TSO unbundling rules apply across sectors, so the gas TSO must also be independent from electricity suppliers and producers and the electricity TSO must be independent from gas suppliers and importers.

#### 2.4 ***Distribution System Operation***

Distribution system operation refers to the transport of natural gas on mid pressure and low pressure networks towards the end consumers (industry, small and mid-scale companies, households), that use the supplied gas for their own consumption. The operator of such networks is usually called a distribution system operator or DSO.

A DSO operates, maintains and develops its own mid- and low- pressure network. As is the case for TSOs, DSOs are obliged to give objective, non-discriminatory and transparent access to their networks to distribution network users. The operation of a distribution network is a regulated activity that is granted a legal monopoly within the boundaries of the operating territory attributed to each DSO. The Guarantors are DSOs. As is the case for DSOs in the electricity sector, DSOs in the gas sector in Flanders are allowed to use an operating company ("*werkmaatschappij*") to operate the grid in their name and for their account. As described in more detail below in section 2.3 of "*Part VIII – Regulatory Framework applicable to the Flemish DSOs*", the Guarantors have also mandated Eandis System Operator as their operating company in this regard.

Wholesale and Retail Suppliers are a DSO's customers<sup>28</sup>.

Currently, the Flemish Region counts a total number of 11 gas DSOs, 7 of which are the Guarantors which cover just over 80 per cent of the Flemish Region in terms of the number of end customers as well as in geographical area.

#### 2.5 ***Retail Supply***

The retail supply of gas refers to the sale of gas to end consumers. The retail supply to household consumers in the Flemish Region is being coordinated and managed by several commercial suppliers competing in a liberalised market. In all three regions (*i.e.* Flanders, Wallonia and Brussels) a licence is required to engage in retail supply of gas. The relevant authority (*i.e.* the VREG, CWaPE and the Brussels Government) will only grant such licence to individuals or companies that comply with certain criteria, e.g. relating to technical and financial capabilities.

In the Flemish gas market, the largest suppliers are (1) Engie Electrabel with a market share of 37.78%, (2) EDF Luminus (18.09%), (3) Eni (14.05%), (4) Essent (7.91%) and (5) Lampiris (6.80%). Market share data as per 31 September 2016<sup>29</sup>.

---

<sup>28</sup> A third type of customers constitutes of retail users that, because of payment problems, have been dropped by commercial gas suppliers. Flemish regulation provides that the DSOs have in such instance an obligation to supply these customers with gas.

## 2.6 *Customers*

Pursuant to the Second EU Gas Directive<sup>30</sup>, and very much in line with the liberalisation process for the electricity market, all customers are eligible to choose their gas supplier<sup>31</sup>. The chosen supplier must, in turn, be provided with a "right of access" to the relevant gas transportation network to ensure that gas is supplied to the end customer<sup>32</sup>.

## 2.7 *Belgian Regulators*

Very much in line with the competencies of the respective regulators for electricity distribution, the federal regulator CREG, together with the three regional regulators (VREG, CWaPE and Brugel), are responsible for monitoring and surveying the Belgian gas market, each within the competencies attributed to it by law. The VREG was vested with the powers to establish the distribution tariff methodology and the approval of the proposals for the distribution tariffs submitted by the DSOs. As described in more detail below in section 3.1 of "*Part VIII – Regulatory Framework applicable to the Flemish DSOs*", the Guarantors as Flemish DSOs need to submit their tariff proposals to the Flemish regulator VREG.

## 2.8 *Basic Figures for the Gas Market*

According to the most recent available statistics, there were approximately 2,626,000 access point for gas in Belgium (2014<sup>33</sup>), based on the number of gas meters. Total net length (pipelines for gas) on Belgian territory amounts to 74,795 km (2014)<sup>34</sup>. According to preliminary Eurostat figures for 2015<sup>35</sup>, total natural gas consumption in Belgium amounted to 178.1 TWh (2014: 162.7 TWh).

---

<sup>29</sup> Source: <http://www.creg.be/nl/consumenten/energiemarkt/marktaandelen-energieleveranciers> (consulted on 11 May 2017)

<sup>30</sup> This directive should have been implemented at the latest on 1 July 2004 but the final act of Belgium's implementation process was adopted on 17 July 2008 (Décret du 17 juillet 2008 modifiant le décret du 12 avril 2001 relatif à l'organisation du marché régional de l'électricité), see <http://eur-lex.europa.eu/legal-content/EN/NIM/?uri=celex:32003L0055>.

<sup>31</sup> Article 23 of Directive 2003/55/EC of the European Parliament and of the Council of 26 June 2003 concerning common rules for the internal market in gas and repealing Directive 98/30/EC.

<sup>32</sup> See article 18 of the above mentioned Directive.

<sup>33</sup> Source: Febeg on [https://www.febeg.be/sites/default/files/febeg\\_annual\\_report\\_2015\\_nl.pdf](https://www.febeg.be/sites/default/files/febeg_annual_report_2015_nl.pdf) (consulted on 11 May 2017)

<sup>34</sup> Source: Eurogas, Statistical Report 2015 (<http://www.eurogas.org/uploads/2016/flipbook/statistical-report-2015/index.html#p=2>), consulted on 11 May 2017

<sup>35</sup> Source: Eurogas, press release "*Gas demand in EU rises for the first time in four years, according to new Eurogas data*" (30 March 2016)

## PART VIII – REGULATORY FRAMEWORK APPLICABLE TO THE FLEMISH DSOs

### 1. Natural monopoly and regulation necessity

A DSO's activity of energy distribution is considered to be a "**natural monopoly**" activity, meaning that on this specific market segment one company can produce a desired output at a lower social cost than two or more companies placed in competition because of both high fixed costs and economies of scale. This monopolistic position (together with their several public service obligations) explains why DSOs (such as the Guarantors) and their operating company (such as the Issuer) are regulated. Regulators *inter alia* define or approve the level of tariffs and/or profits that DSOs are allowed to make and permanently verify the professional and managerial reliability of a DSO.

This specific market position is acknowledged in the Flemish Region as well where the operation of a distribution network is a regulated activity that is granted a legal monopoly within the boundaries of the operating territory attributed to each DSO. The paragraphs below describe three important aspects of this regulatory framework: the unbundling regime applicable to Flemish DSOs (2.1 and 2.2), the licence requirements (2.3) and the tariff framework (3).

### 2. The unbundling regime and licence requirements

#### 2.1 General

European legislation contains unbundling rules for DSOs and TSOs designed to ensure that there is no conflict of interest for these system operators in the delivery of their functions and no incentive to carry out their activities in a manner which might favour certain parties over other parties in the energy markets. These rules ensure that DSOs and TSOs are not allowed to operate or have an interest in the businesses of energy generation and energy supply. There are different levels of unbundling: accounting, functional, legal and ownership unbundling.

The Third Energy Package<sup>36</sup> in principle only requires TSOs to be fully "ownership" unbundled<sup>37</sup>. European legislation does not oblige DSOs to be "ownership" unbundled but imposes legal and functional unbundling. This is the case in Belgium as well where only TSOs are subject to the most stringent rules on ownership unbundling.

The Flemish Region has introduced specific unbundling rules applicable to DSOs (and thus the Guarantors) and their operating companies.

#### 2.2 Unbundling of the Flemish DSOs

Already since the beginning of the liberalisation of the energy market the Flemish Region opted for a model of legal and functional DSO unbundling. Unbundling rules for DSOs and their operating companies are specified in both (i) the Flemish Decree on Intermunicipal Cooperation of 6 July 2001 (the "**DIS**") and (ii) the Energy Order of the Flemish Government of 19 November 2010 (the "**Energy Order**"). These rules affect both the Guarantors as DSO and the Issuer as operating company.

The DIS stipulates that all private persons active as energy producer or energy suppliers are excluded from participating in an intermunicipal association. In addition, the Energy Order contains *inter alia* the following unbundling restrictions:

- *Maximum capital participation of 30% in a DSO.* Companies active in electricity generation or import of natural gas, intermediaries or companies holding a supply licence ("**Production or Supply Entities**") or affiliates or associated companies of those

<sup>36</sup> With regard to the electricity market it concerns the Third Electricity Directive, for the gas market, it concerns the Third Gas Directive.

<sup>37</sup> Whilst the Third Energy Package considers the "ownership model" to be the strongest model for the independence of a TSO, the European Directives provide for two alternative models for Member States which were unable to implement the ownership unbundling immediately: (i) the independent system operator ('ISO') and the independent transmission operator ('ITO').

companies are prohibited from owning individually or jointly more than 30% of the capital of a DSO or its operating company (*werkmaatschappij*). This prohibition extends to affiliates of suppliers and producers and is not limited to the actual operating companies active in supply or generation.

- *No participation in Production or Supply Entities.* DSOs and their operating companies cannot directly or indirectly participate in Production or Supply Entities (or their affiliates or associated companies of those companies).
- *Corporate governance restrictions.* The other unbundling restrictions mainly relate to corporate governance and provide amongst others that:
  - (i) a DSO or its operating company may not call upon Production or Supply Entities or their affiliates or associated companies of those companies to perform strategic and confidential tasks;
  - (ii) the board of directors of a DSO or its operating company should consist of at least 70% directors designated by the public shareholders, the board of the DSO should have at least 50% independent directors and the board of directors of the operating company should consist of at least 70% independent directors; and
  - (iii) members of the management of the DSO or its operating company are prohibited from acting as board members of Production or Supply Entities.

The VREG may revoke a Guarantor's license or the Issuer's approval as operating company (see section 2.3 below) in accordance with article 4.1.4, §4 of the Energy Decree in case the unbundling rules described above would no longer be complied with. However, the Guarantors and the Issuer deem this risk to be very remote since they meticulously comply with the unbundling rules, which is in addition monitored on an ongoing basis by its regulators. Furthermore, the VREG may never proceed to such a drastic decision before a prior notification to the relevant Guarantor (or the Issuer) allowing it to rectify the situation or to object to the proposed withdrawal.

## 2.3 *Licence requirements*

### *General*

The Guarantors need a license granted by the VREG and the latter's approval to use the Issuer as their operating company.

Any DSO for electricity and/or gas in the Flemish Region needs to be appointed or "licensed" by the VREG as stipulated in the Energy Decree. The conditions and procedure for such appointment are laid down in the Energy Order. An appointment is valid for a renewable period of 12 years.

The key characteristics to be demonstrated by a candidate-operator relate to:

- legal ownership or sufficient exploitation rights over a distribution grid;
- financial and technical capabilities;
- professional reliability; and
- managerial and legal independence of the candidate.

The VREG extensively controls the DSOs' compliance with the appointment requirements and conditions on a permanent basis.

The Guarantors were appointed, in respect of their activities relating to the distribution of electricity, by decisions of the VREG on 5 September 2002 for a twelve year period, and, in respect of their activities relating to the distribution of gas, by decisions of the VREG on 14 October 2003, equally for a twelve year period.



After the initial appointment of the Guarantors, a number of corrective measures were taken for IMEA, Iveka and Intergem (gas activity), due to the split-up of the former gas DSO IGAO into these three entities. The initial appointment of Gaselwest has also been amended in the past, following a number of territory exchanges between Gaselwest and a pure intermunicipal company in relation to the municipalities Hooglede and Horebeke.

#### *Renewal of licences in 2015*

##### *Distribution of electricity*

On 5 May 2014 each of the 7 Guarantors formally requested the VREG to renew their DSO appointment for the distribution of electricity for a new 12-year period starting on 6 September 2014. On 3 February 2015 the VREG decided in favour of a renewal of the DSOs' electricity distribution licences. The renewed licences are in principle valid for a twelve year period expiring on 5 September 2026.

Furthermore, on 24 February 2015 the VREG also renewed its approval for the Guarantors to use Eandis System Operator as their operating company, for the same twelve year period until 2026.

##### *Distribution of gas*

With the exception of Imea, whose license for gas distribution terminates on 1 January 2021, in 2015 the Guarantors equally filed their application for a renewal of their gas licence with the VREG. On 29 September 2015 the VREG decided in favour of a renewal of these DSOs' gas distribution licences. The renewed licences are valid for a twelve year period expiring on 14 October 2027.

The VREG decision of 24 February 2015 allowing the Guarantors to use Eandis System Operator as their operating company, also applies to the Guarantors' gas distribution activities. This was confirmed in a letter by the VREG dated 1 October 2015.

### 3. **Tariff Framework**

#### 3.1 ***General: the nature of distribution grid fees***

For their distribution services, DSOs such as the Guarantors charge a fee to the energy suppliers. The suppliers add this fee to the end consumers' energy bill. The bill of suppliers that goes out to customers thus includes not only the energy that was used (and a profit margin), but also the fees that were invoiced by DSOs for distribution of the energy. Contrary to the fees for the use of the grid, costs for the connection to the distribution grid are directly billed to the end customer.

The fee charged by the DSOs is called a distribution grid fee. The tariffs of this distribution grid fee, are based on a tariff methodology common to all DSOs, and are fixed for each individual DSO and for each of electricity and gas distribution separately. In practice this means that there may be differences between the tariffs charged by each Guarantor, dependent on the level of their operational costs.

The grid tariff structure is based on the cascade principle: end-users pay for the costs of the grid level to which they are connected and the costs of all higher grid levels proportionally to the use of these grid levels. In the electricity market this cascade principle is fully implemented as the DSOs pay the TSO for the use of the transmission grid. The transmission tariffs of Elia System Operator NV, the Belgian electricity TSO, are hence included in the electricity distribution tariffs of the DSOs which the latter charge to the suppliers. This is conversely not the case on the gas market where the gas TSO Fluxys Belgium invoices the suppliers directly.

As mentioned above these tariffs are regulated, which entails that the distribution grid fees are (i) based on a tariff methodology established by the regulator in principle for the entire regulatory period (currently 4 years) and (ii) have to be submitted for prior approval (i.e. before being actually charged) to the regulator. The regulator will exercise a control on the proposed distribution grid fees. This takes the form of a check in advance ("*ex ante*") when the DSOs' tariff proposals are submitted for approval. At this moment the regulator can reject elements of the budgeted costs and the regulator will establish the allowable income for a DSO. Afterwards ("*ex*

post"), i.e. after the year for which an allowable income was established, the DSO merely has a reporting obligation and is obliged to submit a detailed report to the regulator regarding the actual costs incurred (both for the so-called exogenous and endogenous costs<sup>38</sup>) during the previous year. The regulatory framework consists of multi-annual tariffs during which tariffs in principle can only change in limited circumstances or according to pre-determined mechanisms such as an indexation mechanism. It aims at sufficiently remunerating the DSOs enabling them to carry out the duties imposed on them and realising a fair remuneration as a return on the capital invested.

Tariffs are public, apply for the whole of the territory of each DSO and are not subject to negotiation with customers. The currently applicable tariffs can be retrieved on the VREG website and on the Issuer's website.

Only the Guarantors (and not the Issuer) obtain their income directly from these grid fees. Where certain costs are not taken into account in the regulated tariffs, the economic cost hereof is to be borne by the shareholders of the Guarantors (through a decrease in profit).

As mentioned below under *Summary of the principal activities of the Issuer and its role within the Eandis Economic Group* in section 1.1 of "Part IX – Description of the Issuer and the Guarantors", the Issuer operates the distribution network and exercises public service obligations for electricity and gas in the name and for the account of the Guarantors. The Issuer performs these operational activities at cost without charging any commercial margin to the Guarantors. The below paragraphs on tariff regulation therefore mainly focus on the Guarantors as they are subject to tariff regulation.

The cash cycle within the Eandis Economic Group can be summarized as follows:

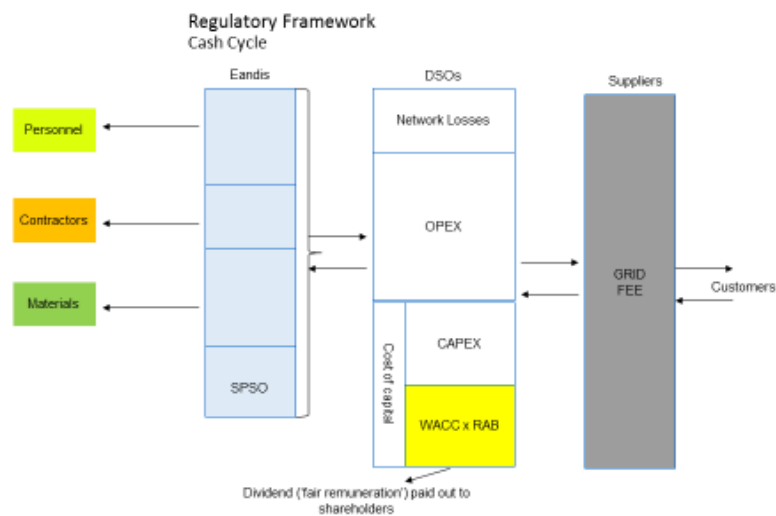

Legend:

- SPSO: social public service obligations
- Opex: operational expenditures
- Capex: capital expenditures
- WACC: weighted average cost of capital

<sup>38</sup> See below in Section 3.5 Exogenous Costs and Endogenous Costs.

- RAB: regulatory asset base

### 3.2 *Overview of tariffs applicable to the Guarantors*

The Guarantors are subject to extensive tariff regulation at different levels. The tariff framework has been modified and extended on several occasions and might further evolve in the future. The competence to set distribution grid tariffs is now with the Flemish Region.

The said tariff framework was first put into place in the mid-nineties in view of the implementation of the First European Energy Directives. In the following years, the framework went through an evolutionary process that focused on strengthening the liberalised energy market with the Second European Energy Directives. The Second European Energy Directives required as of 1 July 2007 the legal and functional separation of the distribution activities from other activities not relating to distribution. The "Third Energy Package" published in 2009 continued and reinforced this trend, and granted greater autonomy to the regulator to fix or approve the tariffs.

Until July 2014, the federal state and each of the Belgian regions had their own regulatory body for the electricity and gas market with complementary competencies. The federal regulator CREG was principally responsible for tariff setting in respect of the DSOs, whilst the regional regulators (such as the Flemish regulator, the "VREG") were responsible for licensing and operational issues at the distribution level.

Pursuant to the Belgian Sixth State Reform the tariff-setting competences for distribution grid tariffs have been transferred to the Regions from 1 July 2014. In the Flemish Region, the VREG has become responsible for the distribution grid tariffs. On 14 March 2014 the Flemish Parliament approved a Decree altering the Flemish Energy Decree to formally appoint the VREG as the regulator for distribution grid tariffs and to anticipate the implementation of these new tariff competences in the Flemish Region as from July 2014.

Until the end of 2015 no specific substantial legislation for the Flemish distribution grid tariffs was in place. To cater for such a comprehensive legal framework the Flemish Decree of 27 November 2015 has amended the Energy Decree, introducing a legal framework for the distribution tariffs.

### 3.3 *Chronological overview of tariff methodology and tariffs*

To allow for the orderly transfer of tariff setting responsibilities, the CREG agreed in April 2012 with all DSOs (including the Guarantors), that the tariffs of the regulatory period 2009-2012 (essentially a "cost-plus" model combined with a rate of return scheme) would be prolonged for 2013 and 2014, with the option of further prolongation into 2015, should the tariff setting process be delayed.

A prolongation into 2015 was however not required because on 30 September 2014 the VREG published the tariff methodology for the transitory tariff period 2015-2016 and approved the tariffs for the Guarantors on 18 December 2014. For the transitory period 2015-2016 the VREG decided to evolve to an income-based regulation method (*inkomstenregulering*), thereby following the approach maintained by the Dutch and UK regulators. From 2017 onwards a new regulatory period entered into force also based an income-based regulation method (*inkomstenregulering*).

The table below gives an overview of the tariffs and the tariff methodologies approved and applied since 2009.

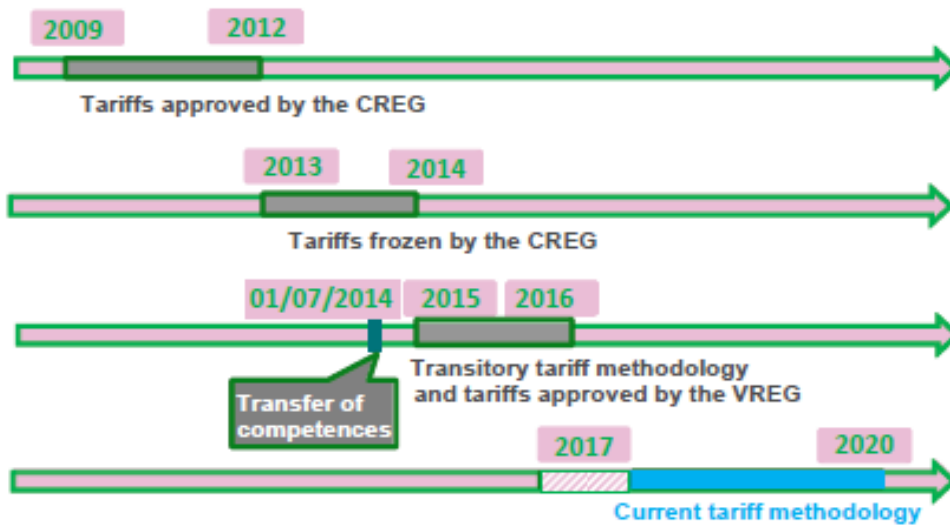

### 3.4 *Legislation and tariff methodology applicable in the regulatory period 2009-2012 (and 2013-2014)*

In the regulatory period 2009-2012 (and for the prolonged years 2013-2014), the framework for the tariffs was set out in the federal Law of 12 April 1965 on the transport of gaseous substances and others through pipes ("**Gas Law**") and the federal Law of 29 April 1999 on the organisation of the electricity market ("**Electricity Law**") and its respective implementing royal decrees, i.e. the Royal Decrees of 2 September 2008 (the "**Tariff Decrees**"), ratified by a Law of 15 December 2009 (the "**Confirmation Law**"). Following the implementation of the Third Energy Package by the federal law of 8 January 2012, these Tariff Decrees were abolished even though the main principles contained therein were still applied in substance. On the basis of this legal framework the CREG (the federal regulator) basically used a "cost-plus" model combined with a rate of return model whereby each DSO's estimated costs (operational and financial, as well as capital costs) were in principle passed through in the tariffs. The CREG could nevertheless reject or challenge certain costs *ex ante* and *ex post* if it deemed these costs unreasonable or inappropriate.

Several litigations have cast doubts on the validity and legality of the said federal tariff framework. These proceedings are no longer relevant for the current regulatory period 2017-2020 and the current tariffs.

### 3.5 *Current tariff methodology applied by the VREG; regulatory period 2017-2020*

#### *The Energy Decree: General*

To completely implement the tariff-setting competences of the Flemish Region and to cater for a comprehensive legal framework, a Flemish Decree of 27 November 2015 amended the Energy Decree<sup>39</sup> to introduce a new legal framework for the distribution tariffs in the Flemish Region. The Energy Decree specifies that the tariff framework should ensure tariff stability and legal security and should allow the DSOs (and thus the Guarantors) to make the necessary investments in their grid. According to the Flemish Government the former does not prohibit that the tariff methodology and the ensuing tariffs are adjusted over the course of a regulatory period in certain circumstances (mainly to comply with the principles of proportionality and non-discrimination). A DSO can request an adjustment of the tariffs as well to the extent this is "strictly necessary" and provided such adjustment takes into account the existing tariff methodology and the integrity of the existing tariff structure.

<sup>39</sup> Ratified and proclaimed on 27 November 2015 and published in the Belgian State Gazette on 10 December 2015.

The Energy Decree further provides for a procedure of preliminary "structured, documented and transparent" consultation between on the one hand the VREG and on the other hand the DSOs to establish the tariff methodology. The VREG is obliged to communicate the finally adopted tariff methodology to the DSOs before the latter have to submit their tariff proposals. The DSOs and the regulator can mutually agree on a submission and approval procedure. In case no agreement is reached, a standard procedure applies.

#### *Tariff guidelines*

In accordance with the rules laid down in the Third Energy Package the core duties of the regulator for tariff setting do not deprive the legislator to issue general policy guidelines which will have to be reflected into the tariff structure and methodology. Article 4.1.32 of the Energy Decree provides for 21 guidelines, amongst others the more general principles of exhaustiveness and transparency, non-discrimination and proportionality. In addition, this Article in the Energy Decree specifies *inter alia* that:

- the criteria to reject costs should be non-discriminatory and transparent;
- the tariffs should reflect the actual costs, to the extent these correspond to the costs made by efficient and structurally comparable DSOs;
- the remuneration for the regulated assets should allow a DSO to make the necessary investments for the execution of its tasks and its "access to capital";
- the charges related to public service obligations are included in the tariffs yet the VREG still has the power to assess the costs generated by the DSOs for those tasks and to benchmark those costs with the other DSOs;
- the tariff methodology should stipulate the determination of the regulatory balances;
- costs which are not under the control of a DSO constitute "**non-manageable costs**"<sup>40</sup>, costs relating to the execution of public service obligations and additionally imposed during a regulatory period qualify as non-manageable costs as well; and
- the DSOs should perform their task in an efficient way.

On the basis of these tariff guidelines the VREG establishes the tariff methodology for a certain regulatory period. Below we describe the tariff methodology for the current regulatory period 2017-2020.

#### *Ex ante revenue cap*

The current tariff methodology for the regulatory period 2017-2020 (the "**TM 2017-2020**") and the transitional tariff methodology which was applied for the period 2015-2016 departs from the hybrid model embodied in the Tariff Decrees (i.e. a cost+ mechanism combined with a rate of return model) to evolve to an "*ex ante* revenue cap model" (*inkomstenregulering*) in which a cap determines the maximum revenue a DSO can collect from the grid users, with the exclusion of so-called "**exogenous**" costs that are beyond the DSO's control. In addition, the TM 2017-2020 caters for an adequate compensation for a DSO's volume risk (i.e. the risk that the actual income derived from the grid fees deviates from the expected income due to a difference between actual and expected off take from the grid users). The latter volume risk compensation is foreseen both on the level of exogenous and endogenous costs.

The cap formula allows for the allowed revenues to be updated annually based on the consumer price index as published by the federal public service for the economy (*Federale Overheidsdienst Economie*) based on the forecasts of the federal planning agency (*Federaal Planbureau*). The

---

<sup>40</sup> As described below in Section 3.5 (*Exogenous costs*) and (*Endogenous costs*), the VREG uses a different terminology: it reverts to endogenous costs (*endogene kosten*) and exogenous costs (*exogene kosten*), which are comparable to manageable and non-manageable costs, although different costs must be included in each cost category.

VREG defends the revenue cap model on the grounds that it incentivises cost efficiencies of the DSOs and that it best remedies the regulator's information handicap. From an investor's point of view, the most important criterion of the tariff methodology is the amount and the stability of the "allowable income".

The table below gives an overview of the classification of the different costs of a Flemish DSO in accordance with the TM 2017-2020.

<b>Costs of the DSO in the context of its regulated activities</b>		
<b>Exogenous costs</b>	<b>Endogenous costs</b>	<b>Other costs</b>
e.g. costs for RECs <sup>41</sup> , RUE <sup>42</sup> Subsidies, transmission tariffs	i.e. depreciations, operational net expenditures and capital remuneration	e.g. penalties, accounting costs and revenue <sup>43</sup>
<i>Included in the tariffs and for the account of grid users</i>	<i>Included in the tariffs but subject to revenue cap regulation</i>	<i>Not included in the tariffs and for the account of the DSO</i>

#### *Exogenous costs*

So-called 'exogenous costs' are left out of the revenue cap. Exogenous costs in general constitute the costs "beyond the control" of the DSO (as such similar to the non-manageable costs concept applied in the regulatory period 2009-2012) and are therefore not subject to incentive regulation.

An important category of exogenous costs are some of the public service obligations of the DSOs. These public service obligations, which are fully integrated in the tariffs, include *inter alia*:

- the net costs for the RUE Subsidies paid out;
- the costs for green and heat power certificates;
- taxes but excluding corporate taxes (if any);
- the transmission tariffs (yet not including the federal contribution added to the electricity grid tariffs);
- the costs for making available gratuitous electricity); and
- certain costs made for technical and administrative support for the execution of the public service obligations.

Other exogenous costs worth mentioning are the charges for non-capitalised supplementary pension schemes or the charges for public sector pensions, paid to employees of a DSO in accordance with statutes, collective bargaining agreements or other sufficiently formalised agreements approved prior to 30 April 1999. In addition, the VREG in principle considers the historically accumulated regulated assets and liabilities to be exogenous as well.

The amount of exogenous costs to be incorporated in the grid fees for a certain year may be modified annually by the VREG depending on the exogenous costs actually incurred in (the) previous year(s). In addition, the future balances as a consequence of the actually incurred exogenous costs and the actual revenues which should cover these costs are subtracted from or added to the grid fees. The annual update of the exogenous costs should, however, prevent the

<sup>41</sup> For a detailed description of RECs in the Flemish Region, see Section *Renewable Energy Certificates in the Flemish Region*; on page 106.

<sup>42</sup> "Rational Use of Energy".

<sup>43</sup> According to the VREG the latter category refers to the "*accounting costs and revenues relating to profit processing*". Such costs mainly consist of civil, administrative and criminal penalties.

over-accumulation of regulatory balances which characterised the federal regulatory scheme 2008-2012 (as extended to 2013 and 2014).

#### *Endogenous costs*

In the revenue cap model the "**non-exogenous**" costs or "**endogenous**" costs will be subject to incentive regulation to stimulate a DSO to work as cost-efficiently as possible and to ensure a sustainable management of the grid. Hence, to cover the endogenous costs, the tariff methodology should allow each DSO a certain amount of fixed revenues ("**allowable income**") which should correspond with the revenues of an efficient DSO.

The VREG has indicated that the initial cost budget in 2017 for a DSO should reflect the recent historical evolution of the endogenous sector costs and the actual share of each individual DSO therein. The endogenous costs will in principle consist of (i) depreciations, (ii) operational net expenditures and (iii) a remuneration for the cost of capital (i.e. equity and debt as described below).

#### *Depreciations and amortisations*

The value of all infrastructure elements that make up a distribution grid of a Flemish DSO is depreciated in accordance with the rules established by the VREG. This depreciation cost is integrally included into the distribution grid fee. The amortisation of surplus values based on the historical indexation and the initial regulated asset base is also taken into account. The VREG believes that goodwill and formation expenses do not qualify as "assets used for distribution grid management purposes". As a consequence, the TM 2017-2020 does not allow that a DSO includes amortisations on goodwill and formation expenses as a endogenous cost in its tariff envelope. These costs cannot be recovered via the tariffs.

#### *Operational net expenditures*

The operating net expenditures incurred by a DSO in the context of its regulated activity, i.e. the incurred operational costs minus the operational revenues, qualify as endogenous costs on which incentive regulation applies.

#### *Capital remuneration*

The DSO is also entitled to receive remuneration for the resources that its capital providers have invested in the distribution grid. The TM 2017-2020 specifies how this weighted average cost of capital ("**WACC**"), i.e. the cost for both equity and debt, is calculated. Compared to the regulatory period 2009-2012 (as prolonged for 2013-2014) costs of debt financing are no longer automatically passed-through in the tariffs.

The TM 2017-2020 specifies that the WACC should incentivise the DSOs to work as cost-efficiently as possible. The WACC is determined ex-ante and should be efficient and realistic. The capital remuneration is calculated with reference to the relevant assets on the balance sheet of the DSO used for the execution of its regulated activities. A different WACC is as such calculated for the (i) regulated asset base (RAB), (ii) a DSO's net working capital, (iii) the green power certificates and heat power certificates and (iv) the positive regulatory balances of the previous regulatory period on asset side of the balance sheet of the DSO.

When applying the WACC<sup>44</sup> to the RAB for the calculation of the capital remuneration the VREG traditionally distinguishes between the cost of equity and debt and proportionally weighs each category of capital by using a gearing factor. Following this calibration an additional adjustment is then made for corporate tax as well.

---

<sup>44</sup> Prior to corporate tax.

### *Cost of equity*

The cost of equity is expressed as a percentage that results from the CAPM pricing formula. The calculation method is based on:

- the assumption by the VREG of a theoretical financing structure composed of 40% equity and 60% borrowed funds (the "**gearing**");
- a risk-free interest rate of 1.43%:
  - based on the two-year weighted average of the historical interest on both German Bund (taking into account for 25%)<sup>45</sup> and Belgian OLO (taking into account for 75%)<sup>46</sup> with a ten year term over the last two years (i.e. 0.80%), and
  - adjusted upwards with 0.63% to take into account the effect of the bond purchases by the European Central Bank;
- an additional premium for the market risk of 5.1 per cent; and
- a parameter reflecting the risk profile of the DSO (the so-called "**beta factor**") established at 0.76 for both electricity and gas.

After using the elements described above the VREG uses a cost of capital of 5.24% in the TM 2017-2020.

### *Cost of debt*

For the calculation of the debt expenditures, embedded debt approach applied in the regulatory period 2009-2012 (and extended in 2013-2014), in which the cost of debt allowance was set to cover the actual cost paid by a company on its borrowings (contrary to the determination of the debt allowance on the basis of market rates) is no longer applied. Yet a favourable regime still applies to a DSO's historical financing and debt commitments entered into prior to the regulatory period are given a different weighting (see last bullet below).

The cost of debt of a DSO consists of the sum of the risk-free interest rate, a risk premium and a fixed add-on for transaction costs. Note that the VREG proposes to use the same gearing parameter as described above (equity/debt ratio of 40/60). The most important elements are the following:

- the VREG uses the same risk-free interest rate parameters as described above albeit with a risk-free interest rate for historical debt of 3.04% compared to 0.80%. for new debt;
- a risk premium of for historical debt of 0.61% compared to 0.64%. for new debt;
- 0.15% is added to the cost of debt to cater for transaction costs (such as the fees paid to advisers); and
- an assumed ratio based on a calibrated weighting of 35% new funding and 65% historical funding.

Using the elements above the VREG proposes to use a cost of debt of 3.04%.

In sum, the VREG uses a WACC before corporate tax of 5.00% in the TM 2017-2020 to calculate the remuneration for the DSOs' cost of capital for the investments in its RAB.

<b>Element</b>	<b>Value</b>
Cost of equity	5.24%

<sup>45</sup> 0.54%.

<sup>46</sup> 0.88%.



<b>Element</b>	<b>Value</b>
Cost of debt	3.04%
<b>WACC</b>	<b>5.00%</b>

#### *Determination of the allowable income of a DSO*

##### *General*

As mentioned above the total allowable income which a DSO can obtain from the periodical distribution grid fees is based upon (i) the allowable income for exogenous costs and (ii) on the other hand the income for endogenous costs.

##### *Allowable income for exogenous costs*

Each year a DSO has to submit a budget to the VREG on the basis of which the VREG determines the allowable income for exogenous costs for the next year. The exogenous costs are not subject to incentive regulation.

##### *Allowable income for endogenous costs*

Endogenous costs are subject to incentive regulation. The VREG has emphasised the importance to identify the amount of the allowable income for endogenous costs in a transparent, non-discriminatory and predictable manner. To this end, the VREG has decided to determine the amount of the allowable income for endogenous costs on the basis of the evolution of the endogenous "sector" costs during a certain "observation period". This observation period equals the four year period starting from the year before the start of the regulatory period. This method of post-calculation allows the VREG to determine a DSO's future income on the basis of the evolution and amount of the sector's most recent (historical) costs.

Furthermore, by referring to the "sector" costs the VREG can induce all DSOs to work as efficiently as possible. For example, in case a DSO's endogenous costs have increased more rapidly than the sector average, the former's future allowable income in the next regulatory period will to a lesser extent correspond to that DSO's latest cost level. Conversely, if a DSO's endogenous costs have decreased more rapidly compared to the costs of its peers, its new allowable income in the next regulatory period will be higher than its most recent cost level.

##### *Adaptations of the allowable income*

The TM 2017-2020 still allows for certain additional adaptations. The endogenous costs of a DSO are adapted taking into account (i) inflation, (ii) an X-factor reflecting positive/negative results of the relevant DSO and (iii) a Q-factor to stimulate the persistent high quality of service to be delivered by the DSO.

**Inflation:** The TM 2017-2020 caters for inflation rate evolutions. In practice this is implemented by a dual-step approach. On the one hand the historical values of endogenous sector costs are updated at the beginning of every regulatory period, and on the other hand a DSO's allowed income is adapted "annually". The inflation rate is measured on the basis of the retail price index.

**X-factor:** The adaptation of a DSO's allowed income on the basis of inflation is corrected by a so-called "X-factor". This X-factor indicates to what extent a DSO's tariffs can increase annually assuming that the DSO performs its tasks efficiently. The use of the X-factor constitutes a form of incentive-based regulation as it indicates to what extent a DSO has to deliver extra efforts to increase its efficiency and productivity. Through the X-factor, consumers directly participate in the expected cost reductions in the form of lower tariffs in the next regulatory period. On the other hand, a DSO can also benefit as long as it manages to reduce costs in excess of the X-factor. The residual cost savings can then be retained in the form of higher profits in the next regulatory period.

Q-factor: A DSO could exaggerate its cost savings benchmarked against the X-factor, possibly at the expense of the quality of its services. To mitigate this problem, the TM 2017-2020 also contains a Q-factor. The Q-factor or "quality factor" measures the level of quality of a DSO's services (or the lack thereof) and is translated into a financial remuneration (or a financial punishment).

### 3.6 *Prosumer tariff*

Traditionally the distribution grid tariffs are measured in function of the injected and purchased kilowatt hours ("**kWh-tariffs**"). To calculate these tariffs separate meters for off take and injection should be installed at the end-user premises to measure the real injection and the real off take. Yet for decentralised production installations with a capacity of  $\leq 10$  kW, no separate meters are legally required.

In the regulatory period 2009-2012 Prosumers<sup>47</sup> only had to contribute to the costs of the network at the rate of the net balance measured on their meter between the quantities consumed and injected on the network ("**Compensation**"). As a consequence of this Compensation the distribution tariffs of the DSOs did not reflect the actual electricity volumes which were transiting over the grid (i.e. both off take and injection). For instance, a Prosumer injecting 3,000 kWh and off taking 3,000 kWh in a given year, was charged based on the net meter reading of zero off take and zero injection. Hence, Compensation resulted in a decrease of revenues and afterwards in an upward pressure on the tariffs to be paid by other grid users.

To tackle this grid fee deficit the transitory tariff methodology 2015-2016 and the tariff methodology 2017-2020 introduced a Prosumer tariff. This Prosumer tariff in the form of an additional capacity tariff only applies to Prosumers with a traditional reverse meter ("**Ferrarimeter**") and not to Prosumers which use a bidirectional meter, as the latter meter is able to accurately measure both off take and injection separately. The level of the Prosumer tariff differs depending on the relevant DSO and, more importantly, on the installed capacity of the transformer of the Prosumer measured in kVA. The tariff varies between EUR 67–106 per kW installed capacity. Prosumers are not subject to an injection tariff as they are not connected to the distribution grid through a separate access point for injection. A grid user not benefitting from reverse net metering but who has installed separate "bi-directional" meters for respectively load and injection, is not subject to the capacity tariff but to a separate injection tariff for the electricity injected into the distribution grid.

### 3.7 *Historical regulatory assets and liabilities*

#### *Background*

The regulatory scheme pursuant to the Tariff Decrees as applied in the regulatory period 2009-2012 (and extended for 2013 and 2014) provided for a stimulus for DSOs to operate more productively and efficiently. A distinction was made between "manageable costs" (*beheersbare kosten*) and "non-manageable costs" (*niet-beheersbare kosten*). The former are costs over which the DSO has direct control; the latter are the costs over which the DSO does not have such direct control (e.g. TSO tariffs and public service obligations). The CREG compared both manageable and non-manageable costs actually incurred on a yearly basis with the respective costs foreseen in the budget upon which the original tariff proposals were based. Differences relating to manageable costs were to the benefit of the shareholders of a DSO (bonus) or were borne by them (malus). Deviations relating to non-manageable costs (e.g. depreciations, public service obligations, network losses) and to volumes of transported energy were considered as a global liability or receivable towards the grid users ("**Regulatory Assets or Liabilities** or **RALs**")<sup>48</sup>.

<sup>47</sup> The term "**Prosumers**" (a combination of the terms 'producers' and 'consumers') refers to grid users which both use the grid to withdraw electricity and to inject electricity and additionally benefit from reverse net metering (the reverse meter (*terugdraaiende teller*)). Their injected electricity is produced by their own small decentralised generation installation (equal to or less than 10kW such as solar panels or others).

<sup>48</sup> Regulatory assets represent future revenues associated with costs incurred in an ongoing regulatory period but which are expected to be recovered from grid users in a next regulatory period. Regulatory

These deviations were registered by the Guarantors on an accrual account prior to an approval of the level of these deviations by the regulator following the end of each year of a regulatory period either as a receivable (in case the non-manageable costs actually incurred are higher than the budgeted costs) or as a liability (in case the non-manageable costs actually incurred are lower than the budgeted costs). According to the rules of the Tariff Decrees, at the end of the regulatory period, the allocation of the RALs (as an account receivable or payable) had to be decided by an order deliberated by the Council of Ministers after submission of a proposal by the CREG. Following the adoption of the federal law of 8 January 2012, it was no longer the Council of Ministers but the regulator who needed to decide on the RALs.

#### *Recovery of the RALs and litigation before the Court of Appeal of Brussels*

Some of these costs relating to the years 2008-2009 were recovered during the tariff period 2015-2016 following a decision by the federal regulator the CREG for those two years. However, the CREG did not take a decision on the RALs relating to the years 2010 and 2011 due to the uncertainty of the tariff framework. The CREG argued that such a decision required the preliminary establishment of a tariff methodology and that given the prolongation of the 2009-2012 tariffs for the years 2013-2014 and the then ongoing transfer of tariff setting competences, there was no time, nor the legal basis to establish such a methodology. Yet a procedure was initiated before the Court of Appeal of Brussels by the pure Flemish DSOs (regrouped under the name Infrac) to oblige the CREG to make a decision on these outstanding RALs.

On 30 June 2015, the Court of Appeal of Brussels finally confirmed that a decision on the determination of the RALs does not necessitate the preliminary establishment of a new tariff methodology. In that respect the CREG could not legally argue that the delay caused by the time to set up such tariff methodology was a valid reason to refuse to decide on the determination of the RALs. Nevertheless, the Court ruled that in order to ensure regulatory continuity it would be appropriate that the regulator responsible for the "determination" of the RALs is the same regulator competent for the "allocation" of those RALs. Hence, the Court decided that the VREG should take both the determination and the allocation decision for the relevant RALs. When making those decisions, the VREG should take into account the tariff methodology used by the CREG to "determine" the original tariffs to the extent this methodology complies with the regulatory guidelines contained in the federal Electricity Law. As described below in paragraph "*Actions undertaken by the VREG: 2015-2016 transitory tariff methodology*" and "*TM 2017-2020*", the RALs relating to the years 2010 and 2011 were integrated progressively into the tariffs from 2016 onwards.

#### *Actions undertaken by the VREG: 2015-2016 transitory tariff methodology and TM 2017-2020*

The VREG had already explicitly acknowledged the existence of the historical RALs of the Flemish DSOs before the above ruling of the Court of Appeal of Brussels. In the 2015-2016 transitory tariff methodology the VREG qualified these RALs as exogenous costs. Since the CREG only confirmed the determination of the RALs for the years 2008 and 2009 and given the procedure initiated by the pure Flemish DSOs at the time of the Tariff Decisions, the VREG decided to only include the RALs of 2008 and 2009 in the 2015 and 2016 tariffs (50% of their total amount in 2015 and 50% of their total amount in 2016).

When the VREG established the 2015-2016 transitory tariff methodology in the last quarter of 2014 it was not prone to take a similar decision for the RALs relating to the period 2010-2014. The VREG decided, on 5 October 2015, to amend the 2015-2016 transitory tariff methodology to allow for the integration of a provision for the RALs relating to the period 2010-2014. As such, these RALs were integrated progressively into the tariffs from 2016 onwards. In practice the VREG proposed to integrate in the tariffs of 2016 a provision of 20% of the Regulatory Assets/Liabilities relating to the years 2010-2014 as reported and estimated by the DSOs (on top of the 50% relating to 2008 and 2009 as decided in the 2015-2015 transitory tariff methodology). The regulator confirmed in the tariff methodology 2017-2020 that it intends to steadily and

---

liabilities represent future reductions in revenues associated with amounts obtained in an ongoing regulatory period that are to be credited or refunded to grid users in a next regulatory period.

evenly integrate the remaining 80% in the tariffs of 2017, 2018, 2019 and 2020 (i.e. 20% in each year).

The VREG has indicated that the integration of the RALs relating to the years 2010-2014 constitutes a provisional integration of an "estimate" based on the figures of the DSOs reported to the regulators. The RALs must still be audited and confirmed by the VREG. Once they will have been finally confirmed by the VREG an adjustment will be made between the amounts already integrated in the distribution tariffs for the current regulatory period, and the actual amounts. It is the expectation of the Issuer that a decision is taken by the VREG in the course of this year.

## PART IX – DESCRIPTION OF THE ISSUER AND THE GUARANTORS

### 1. General information on the Issuer, the Guarantors and the Eandis Economic Group

#### 1.1 General information on the Issuer

##### *Legal name, form and place of registration*

The Issuer's name is Eandis System Operator CVBA ("**Eandis System Operator**" or the "**Issuer**"). The company is registered with the register of legal entities ("*rechtspersonenregister*" / "*registre des personnes morales*") of Ghent (section Ghent) under enterprise number ("*ondernemingsnummer*" / "*numéro d'entreprise*") 0477,445,084. The legal entity identifier of Eandis System Operator is 549300WSQWO0M3PK2J78.

The Issuer is incorporated under Belgian law as a limited liability partnership ("*coöperatieve vennootschap met beperkte aansprakelijkheid*" / "*société coopérative à responsabilité limitée*") for an unlimited duration. The company's registered office is at Brusselsesteenweg 199, B-9090 Melle, Belgium. The general telephone number is +32 78 353534. The current Articles of Association of Eandis System Operator have been approved by the Extraordinary General Meeting of Shareholders on 30 December 2015 (notarial deed drawn up by Mr Xavier Desmet, notary public in Antwerp, Belgium – published in the Annexes to the Belgian State Gazette of 4 April 2016).

The Issuer's website can be accessed via [www.eandis.be](http://www.eandis.be).

The Issuer currently has participations in five entities, being De Stroomlijn CVBA ("**De Stroomlijn**"), Atrias CVBA ("**Atrias**"), Synductis CVBA ("**Synductis**"), Warmte@Vlaanderen CVBA ("**Warmte@Vlaanderen**") and Fluvius CVBA ("**Fluvius**") (the "**Subsidiaries**"). De Stroomlijn is fully consolidated with Eandis System Operator. Atrias and Synductis are consolidated according to the equity method. Warmte@Vlaanderen and Fluvius have not been consolidated in the accounts for the financial period ending on 31 December 2016. Please refer to section 2.2 below for more information hereon.

The Issuer, the Guarantors and the Subsidiaries of the Issuer together form the Eandis Economic Group.

##### *Summary of the principal activities of the Issuer and its role within the Eandis Economic Group*

The Issuer develops, manages and maintains low voltage and mid voltage distribution networks for electricity as well as low pressure and mid pressure distribution networks for gas, owned by the Guarantors. Eandis System Operator has been mandated as operating company ("*werkmaatschappij*") of the seven Flemish DSOs that are the Guarantors, and its role is limited to the operation and maintenance of the networks. In their name and for their account, Eandis System Operator operates the distribution network and exercises public service obligations for electricity and gas. Eandis System Operator carries out its operational activities at cost without charging any commercial margin to the Guarantors. This means that all costs incurred by Eandis System Operator (materials and services, personnel costs...) are passed through to the Guarantors according to fixed allocation rules. Each month, Eandis System Operator invoices each of the Guarantors for the operational services rendered.

As further outlined in article 2 of the Issuer's consolidated articles of association, Eandis System Operator's mission is:

- to carry out all activities related to the development, the operations, the use and the maintenance of distribution grids for electricity and gas, including their connections, meters and services to distribution grid users and other market parties,
- to operate all grid-related activities,
- to collect metering data and to manage consumption data,

- to carry out all activities related to the generation and distribution of renewable energy and energy from combined heat-power installations for its shareholders, as far as they are compliant with legislation,
- to carry out all activities related to energy services to distribution grid users,
- in general, to render services and to offer knowhow to distribution grid users,
- the preparation and implementation of the decisions taken by the governing bodies of its shareholders,
- organising the consultation between its shareholders on matters of energy distribution and promoting the collaboration between them.

#### *Relevant markets*

Eandis System Operator operates in 229 cities and municipalities in the Flemish Region and 4 Walloon municipalities which are shareholder of the DSO Gaselwest<sup>49</sup>.

Eandis System Operator has no activities outside Belgium.

### 1.2 ***A brief history of the Issuer***

The Issuer was incorporated under Belgian law as a limited liability company ("*naamloze vennootschap*" / "*société anonyme*") named "*Electrabel Netmanagement Flanders*", abbreviated to "ENF", by notarial deed of 29 April 2002, drawn up by Mr Thierry Van Halteren, associated notary public in Brussels, and published in the Annexes to the Belgian State Gazette on 11 May 2002 under number 20020511-609. The name "*Electrabel Netmanagement Flanders - ENF*" was changed into "*Electrabel Netten Vlaanderen - ENV*" by decision of the Extraordinary General Meeting of Shareholders on 22 September 2003.

On 30 March 2006 the company's Articles of Association were changed: the Issuer's name "*Electrabel Netten Vlaanderen*" (ENV) was changed into "Eandis", the company took the form of a limited liability partnership and a merger was realised with GeDIS and Indexis' Flemish platform (notarial deed of the same date, drawn up by Mr Xavier Desmet, notary public in Antwerp, and published in the Annexes to the Belgian State Gazette on 27 April 2006 under number 06074304). All of the Issuer's capital shares have since then been held by the Guarantors. Until this merger on 30 March 2006, Electrabel Netten Vlaanderen was Electrabel NV's ("**Electrabel**") subsidiary for the management of distribution networks for gas and electricity in the Flemish Region, operating under the name "Netmanagement". GeDIS, a limited liability partnership ("*coöperatieve vennootschap met beperkte aansprakelijkheid*" / "*société coopérative à responsabilité limitée*") with full name "*Gemeentelijk Samenwerkingsverband voor Distributienetbeheer*", incorporated to conform to the legal provisions as to independence, was also responsible for the public service obligations and the implementation of the DSOs' policy on the Rational Use of Energy (RUE). Indexis, a limited liability partnership ("*coöperatieve vennootschap met beperkte aansprakelijkheid*" / "*société coopérative à responsabilité limitée*"), was the metering company that collected energy consumption data and managed this data for billing purposes.

The merger of these three operating companies into a single operating company, Eandis, has contributed to a higher degree of transparency and clarity in the Flemish energy market benefiting consumers and suppliers alike.

The Issuer's current name "Eandis System Operator" was approved by the Extraordinary General Assembly of 30 December 2015, published in the Annexes to the Belgian State Gazette of 4 April 2016, and entered into force on 1 January 2016.

---

<sup>49</sup> Eandis System Operator also carries out a number of operational activities in the Walloon municipality Frasnes-lez-Anvaing on behalf of the latter's operating company Ores Assets.

### 1.3 **General information on the Guarantors**

#### *Legal name and place of registration*

Eandis is the operating company for the Guarantors, which are all DSOs distributing both electricity and gas. The Guarantors are:

1. *GASELWEST* (registered office at 12 President Kennedypark, 8500 Kortrijk, Belgium; general telephone number: +32 78 353534; with enterprise number 215,266,160 (RLE Ghent, section Kortrijk)): services a territory of 60 cities and municipalities in the provinces East- and West-Flanders that includes the cities of Kortrijk, Ypres and Oudenaarde. Gaselwest's operating territory also includes four Walloon municipalities.
2. *IMEA* (registered office at 233 Merksemsesteenweg, 2100 Deurne-Antwerp, Belgium; general telephone number: +32 78 353534; with enterprise number 204,647,234 (RLE Antwerp, section Antwerp)): services a territory of 6 cities and municipalities in the Antwerp region, including the city of Antwerp.
3. *IVERLEK* (registered office at 58 Aarschotsesteenweg, 3012 Wilsele-Leuven, Belgium; general telephone number: +32 78 353534; with enterprise number 222,343,301 (RLE Leuven)): services a territory of 52 cities and municipalities in the provinces Flemish-Brabant and Antwerp, including the cities of Mechelen and Louvain.
4. *IMEWO* (registered office at 199 Brusselsesteenweg, 9090 Melle, Belgium; general telephone number: +32 78 353534; with enterprise number 215,362,368 (RLE Ghent, section Ghent)): services a territory of 42 cities and municipalities in the Provinces East- and West-Flanders, including the cities of Ghent, Bruges, Lokeren and Ostend.
5. *SIBELGAS* (registered office at 12 Sterrenkundelaan, 1210 Sint-Joost-ten-Node (Brussels), Belgium; general telephone number: +32 78 353534; with enterprise number 229,921,078 (RLE Brussels)): services a territory of 5 cities and municipalities to the north of Brussels.
6. *IVEKA* (registered office at Koningin Elisabethlei 38, 2300 Turnhout, Belgium; general telephone number: +32 78 353534; with enterprise number 222,030,426 (RLE Antwerp, section Turnhout)): services a territory of 46 cities and municipalities in the Province Antwerp, including the city of Turnhout.
7. *INTERGEM* (registered office at 11 Franz Courtensstraat, 9200 Dendermonde, Belgium; general telephone number: +32 78 353534; with enterprise number 220,764,971 (RLE Ghent, section Dendermonde)): services a territory of 23 cities and municipalities in the Provinces Flemish-Brabant and East-Flanders, including the cities of Aalst, Sint-Niklaas and Dendermonde.

#### *Legal form*

The Guarantors are regulated public law entities. Please refer to section 3.2 below for information on the administrative regime applicable to the Guarantors and its consequences.

## Markets

The Guarantors have no activities outside Belgium. The map below indicates the operating territories of each of the seven Guarantors for their activities relating to the distribution of electricity.

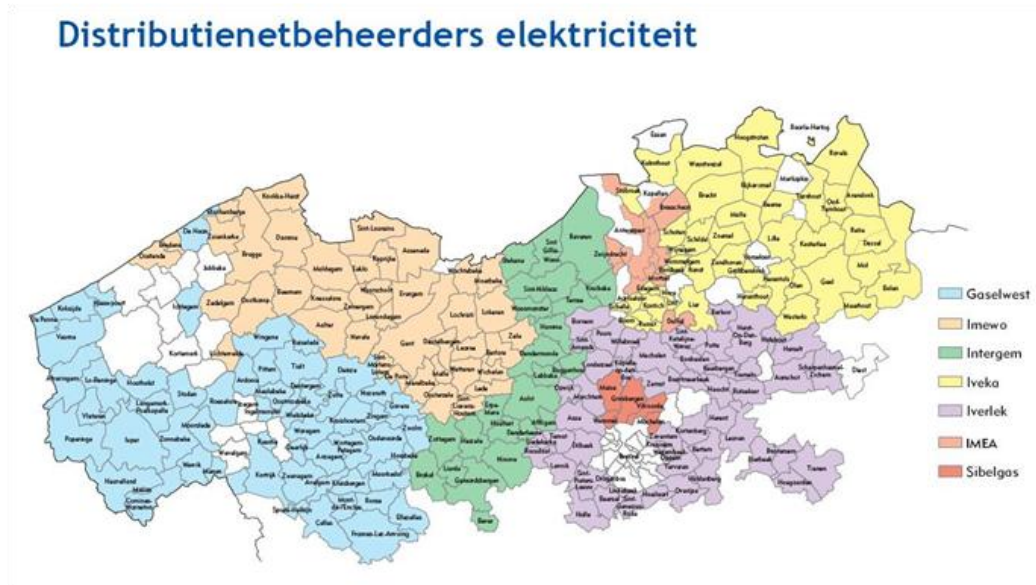

The map below indicates the operating territories of each of the seven Guarantors for their activities relating to the distribution of for gas.



## Summary of principal activities of the Guarantors and role within the Eandis Economic Group

The object and purpose of the Guarantors is comprised in article 3 of their respective articles of association and comprises of the management and operation of gas and electricity distribution systems. This comprises responsibility for the development of these systems, as well as for their viability and security. The Guarantors also organise public lighting and are responsible for certain social and other public service obligations.

The Guarantors own the low voltage and mid voltage distribution networks for electricity as well as low pressure and mid pressure distribution networks for gas operated by Eandis System



Operator, and are also the holders of the DSO licence granted by the VREG. Finally, the Guarantors also invoice customers (i.e. the suppliers) themselves.

The table below presents some aggregated basic figures on the network infrastructure for electricity and gas distribution under the management of Eandis System Operator. Although managed by Eandis System Operator, the grid assets remain fully owned by the seven Guarantors.

<b>All figures as per 31 December 2016</b>	<b>Electricity</b>	<b>Gas</b>
Total net length.....	97,667 km	42,837 km
of which .....	low voltage 62,873 km	low pressure 34,865 km
	mid voltage 34,794 km	mid pressure 7,972 km
Number of connections.....	2,664,391	1,773,585
Number of public lighting points.....	849,092	not applicable
Number of social clients .....	62,717	48,461
Budget meters installed .....	98,986	53,480
Active budget meters.....	32,819	23,930

The Guarantors have appointed Eandis System Operator as their operating company in application of the Flemish Energy Decree of 8 May 2009, and the Resolution of the Flemish Government of 19 November 2010. All seven Guarantors were allowed to use the services of Eandis System Operator as their operating company by decision of the VREG dated 24 February 2015.

For a further description of the Guarantors principal activities and their position in the energy market, we refer to "*Description of the Belgian electricity and gas market*". In "*Regulatory Framework Applicable to the Flemish DSOs*", the regulations applicable to the tariffs used by the Guarantors are set out.

#### 1.4 *A brief history of the Guarantors*

Before the liberalisation of the energy market in Flanders, the so-called intermunicipal companies were integrated entities: being owners of the grids, they transported electricity and gas over these grids, operated, maintained and developed them. They also collected the energy consumption data and supplied electricity and gas to end consumers (being households, small and medium sized companies and public authorities).

Due to the liberalisation process, the energy landscape changed drastically: commercial activities and infrastructure operations could no longer be conducted by a single entity. As a result, the intermunicipal companies had to dispose of their electricity and gas supply activities and became DSOs active in the business of operating distribution grids only.

The major players on the liberalised Flemish electricity market are the electricity producers, the transmission system operator ("**TSO**") and the distribution system operators ("**DSOs**"), the wholesale and retail suppliers, the end consumers and the regulators. Please refer to "*Part VII – Description of the Belgian Electricity and Gas Market*" for more information on the roles of the relevant market participants.

2. **The Issuer**

2.1 **Corporate organisation of the Issuer**

As per the end of December 2016, Eandis System Operator employed 3,967 people, corresponding to 3,793.23 full-time equivalents (FTE). Its corporate structure, its corporate bodies and key personnel are briefly described below.

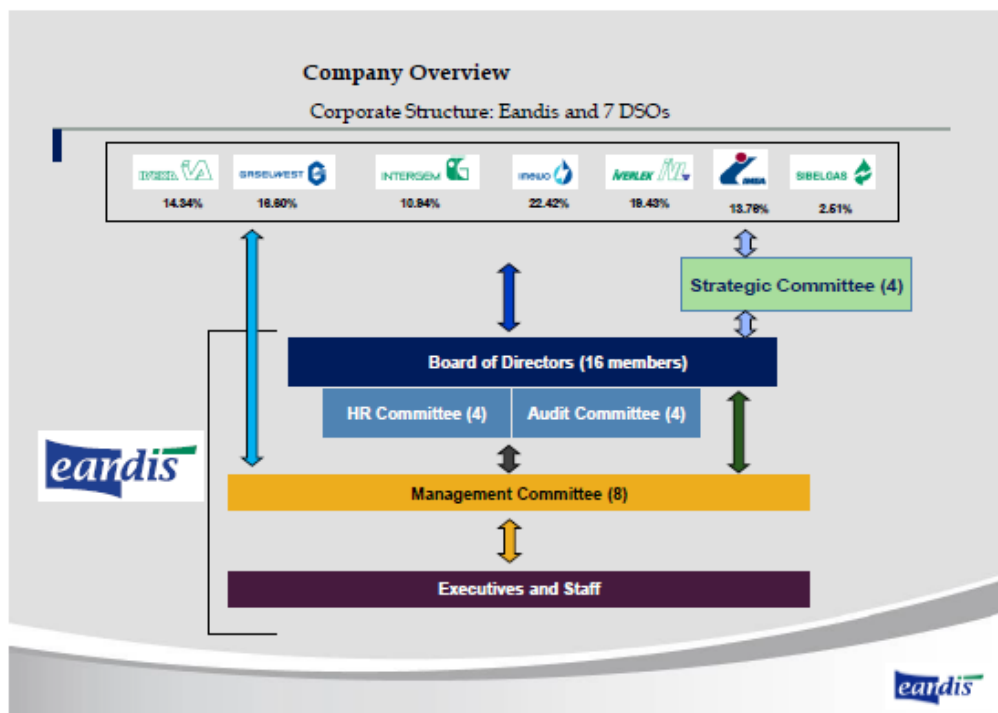

*Board of Directors*

The Board of Directors of Eandis, which according to the Issuer's Articles of Association consists of a maximum of twenty members, is responsible for Eandis's general policy decisions. Currently the shareholders of the Issuer have appointed sixteen<sup>50</sup> Board members.

<b>Name and function</b>	<b>Major other functions at the date of the Prospectus.</b>
Piet BUYSE, <i>Chairman</i>	Mayor of the City of Dendermonde; Chairman of the Board of Directors of Intergem
Koen KENNIS, <i>1<sup>st</sup> Vice-Chairman</i>	Alderman of the City of Antwerp; Chairman of the Board of Directors of IMEA
Geert VERSNICK, <i>2<sup>nd</sup> Vice-Chairman</i>	City councillor in Ghent; Provincial alderman of East-Flanders
Louis TOBBACK, <i>3<sup>rd</sup> Vice-Chairman</i>	Mayor of the City of Louvain; Minister of State; member of the Board of Directors of Iverlek
David COPPENS, <i>Director</i>	Member of the Municipal Council in Aalst; member of the Board of Directors of Intergem
Jean-Pierre DE GROEF, <i>Director</i>	Mayor of Machelen; Chairman of the Board of

<sup>50</sup> These Board seats are distributed among representatives of the DSO's as follows: IMEA: two seats; GASLWEST: three seats; IVERLEK: three seats; IVEKA: two seats; IMEWO: three seats; SIBELGAS: one seat; and INTERGEM: two seats.

<b>Name and function</b>	<b>Major other functions at the date of the Prospectus.</b>
	Directors of Sibelgas
Christof DEJAEGHER, <i>Director</i>	Mayor of Poperinge; member of the Board of Directors of Gaselwest
Paul DIELS, <i>Director</i>	Mayor of Lille; Chairman of the Board of Directors of Iveka
Greet GEYPEN, <i>Director</i>	Alderman in the City of Mechelen; Chairman of the Board of Directors of Iverlek
Luc JANSSENS, <i>Director</i>	Alderman in Kapellen; member of the Board of Directors of IMEA
Piet LOMBAERTS, <i>Director</i>	Chairman of the Municipal Council of the City of Kortrijk; member of the Board of Directors of Gaselwest
Luc MARTENS, <i>Director</i>	Mayor of the City of Roeselare; Chairman of the Association of Flemish Cities and Municipalities; Chairman of the Board of Directors of Gaselwest
Katrien PARTYKA, <i>Director</i>	Mayor of the City of Tienen; member of the Flemish Parliament
Ilse STOCKBROEKX, <i>Director</i>	Member of the Municipal Council in Schoten; Vice-chairman of the Board of Directors of Iveka
Filip THIENPONT, <i>Director</i>	Mayor of Merelbeke; member of the Board of Directors of Imewo
Paul Teerlinck, <i>Director</i>	Chairman of the Board of Directors of Imewo

All mandates terminate on the general meeting of shareholders to be held in respect of the financial year ending 31 December 2018.

Nick Vandeveldel was appointed Secretary to the Board of Directors of the Issuer. He is Secretary General of Eandis System Operator, and in that function responsible for corporate administration, investor relations, legal affairs and the complaints commission Eandis. The above Directors, as well as the Secretary of the Board of Directors have their business address at Brusselsesteenweg 199, B-9090 Melle, Belgium.

#### *Management Committee*

The Board of Directors has entrusted the Management Committee with the day-to-day management of the company from an operational and organizational perspective. The day-to-day execution of the decisions taken by the Guarantors and certain daily management tasks of these DSOs have also been entrusted to the Management Committee. The members of the Management Committee take part in the Eandis Board of Directors meetings, solely with an advisory role and without exercising any voting rights.

The current members of the Management Committee are:

*Walter Van den Bossche*, CEO and Chairman of the Management Committee, was born in 1956. He holds an Economics Degree. He has built his career in the energy sector at Intercom, Electrabel and Electrabel Netten Vlaanderen in several executive and management positions, mostly within financial and administration departments. Prior to his current function at Eandis System Operator, Mr Van den Bossche was Head of the Finance & Administration Department at both Electrabel Netten Vlaanderen and Eandis, and Vice-Chairman of Eandis's Management Committee.

*Guy Cosyns*, born in 1962, is an electrotechnical engineer. He has built a long career in the energy sector (at Intercom, Electrabel, ENV, Electrabel Customer Solutions and Eandis) in commercial, technical and regulatory affairs management positions. In 2005, he became responsible for Eandis's operating area Leie-Schelde. He joined Eandis's Management Committee in 2013 as Director Customer Operations.

*Wim Den Roover* is currently responsible for the Department Network Operations at Eandis. Born in 1961, he obtained an engineering degree. Prior to his current function at Eandis, he was responsible for the different Smart Programmes at Eandis. He has developed his career in several infrastructure areas and was also responsible for a number of internal projects.

*Jean Pierre Hollevoet*, responsible for Network Management, was born in 1962. He holds a technical engineering degree. Previous to his current position, Mr Hollevoet was a.o. responsible for supply chain and facility management, procurement and asset management at Eandis. He has gained experience in several operational functions in the utility business during a 30 year career.

*David Termont*, CFO, is currently responsible for Financial & ICT Management at Eandis System Operator. He was born in 1970 and holds an Economics Degree. He started his professional career as advisor to an Alderman of the City of Ghent. Prior to joining Eandis, he was in charge of GeDIS's Customer Care Department. Until 2013, Mr Termont was responsible for the Customer Care Department.

*Donald Vanbeveren* is bearing responsibility for Eandis System Operator's Regulation & Strategy Department. Mr. Vanbeveren was born in 1958 and he is a civil engineer. He started his professional career at Vynckier (now GE). In the energy sector, he took up several functions starting with technical functions, but also financial functions, unbundling of the energy market and asset management.

*Werner Verlinden* is responsible for the Department HR & Organisational Management. He has built his 35 year career in several HR-related functions throughout the energy sector, a.o. with functions at Ebes, Electrabel and Eandis. He became a member of the Management Committee on 1 January 2015.

#### *Audit Committee*

Eandis System Operator has installed an Audit Committee. Currently, its members are Paul Diels (Chairman), Luc Janssens, Koen Kennis and Paul Teerlinck.

The Audit Committee has an advisory competence and reports its findings to the Board of Directors. The responsibilities of the Audit Committee relate to control over the company's accountancy, its control systems, the proper application of accounting rules, financial reporting and budgeting.

#### *HR Committee*

Eandis System Operator has also installed an HR Committee. It is chaired by Mr Piet Buyse and its other members currently are Greet Geypen, Koen Kennis, and Paul Teerlinck.

The HR Committee has an advisory competence and reports its findings and guidelines to the Board of Directors. The HR Committee's tasks include advising on Eandis System Operator's general salaries policy. The Committee is also consulted on nominations of managers within the company.

Eandis System Operator's current Articles of Association stipulate that both the HR Committee and the Audit Committee are composed of a maximum of five members. However, only four members in each of these committees have been appointed at the moment. There is currently no intention to appoint a fifth member.

#### *Strategic Committee*

The Strategic Committee is functioning as a consultation platform between the Issuer and its shareholders. It is composed of four members. According to the Issuer's Articles of Association,

this committee is being chaired by the Chairman of the Board of Directors, currently Mr Piet Buysse. The three vice-chairmen of the Board are the other members of the Strategic Committee.

#### *Conflicts of interest*

There are no conflicts of interest between the duties of the persons listed above in this section 2.1 to the Issuer and their private interests or other duties. It should be noted that possible conflicts of interest between the duties of the directors of the Guarantors and their private investments or other duties are permanently being scrutinised by the Flemish authorities and by the regional energy regulator VREG.

#### *Corporate governance*

Since the Belgian Corporate Governance Code for Listed Companies (known as the Code Daems, the "**Code**") is primarily aimed at companies with listed shares and given the extensive and specific legal and regulatory requirements applicable on Eandis System Operator, the Issuer has published its own Corporate Governance Charter, which was inspired both by the Code and the Corporate Governance Code for Non-listed Companies (known as the Code Buysse). This Corporate Governance Charter is updated on a regular basis when required by internal or external elements. Eandis System Operator's Corporate Governance Charter can be accessed via the Issuer's website "[http://www.eandis.be/eandis/pub\\_over\\_eandis.htm](http://www.eandis.be/eandis/pub_over_eandis.htm)".

## 2.2 *Eandis System Operator's Subsidiaries*

### *De Stroomlijn*

De Stroomlijn CVBA was established as a limited liability partnership ("*coöperatieve vennootschap met beperkte aansprakelijkheid*" / "*société coopérative à responsabilité limitée*") on 28 December 2006 by notarial deed of the same date, published in the Annexes to the Belgian State Gazette of 22 January 2007 under number 07012863. Its registered office is at 9090 Melle, Brusselsesteenweg 199. The company, hereafter called "**De Stroomlijn**", is registered with the legal enterprise registry of Ghent under number 0886,337,894.

Eandis possesses 1,650 shares out of the 2,577 shares in De Stroomlijn, or 64.03 per cent of the share capital. The other 927 shares are owned by Farys, an intermunicipal company for the distribution and treatment of water (850 shares), and Synductis (77 shares).

De Stroomlijn's Articles of Association attribute to Eandis System Operator the right to nominate four out of seven members of the Board of Directors. David Termont, member of Eandis System Operator's Management Committee, is chairman of the Board of Directors of De Stroomlijn. Nick Vandeveld, secretary to the Board of Directors of Eandis, holds the same position in De Stroomlijn's Board of Directors.

De Stroomlijn's financial statements are fully consolidated with Eandis, according to the integral method.

De Stroomlijn operates as the independent customer contact centre for distribution related matters. On 31 December 2016 the company employed 253 people (or 238,7 full-time equivalents). In 2016 De Stroomlijn processed almost 1,8 million calls, 78.8 per cent of these calls were related to Eandis System Operator's activities.

### *Atrias*

Atrias CVBA was established as a limited liability partnership ("*coöperatieve vennootschap met beperkte aansprakelijkheid*" / "*société cooperative à responsabilité limitée*") on 9 May 2011 by a notarial deed of the same date, published in the Annexes to the Belgian State Gazette of 25 May 2011. Its registered office is at 1000 Brussels, Ravensteingalerij 4, box 2. The company, hereafter called "**Atrias**", is registered with the legal enterprise register of Brussels under number 0836.258.873.

Eandis System Operator owns 93 shares of Atrias's 372 shares, or 25 per cent of the share capital. The other Atrias shares are owned by other entities in the energy distribution sector, being Ores, Infrac CVBA ("**Infrac**"), RESA, Sibelga, AIEG, AIESH and Réseau d'Energies de Wavre.

Eandis System Operator has the statutory right to nominate three Board members and has thus appointed Guy Cosyns, David Termont and Walter Van den Bossche. Eandis also has the statutory right to nominate the Chairman of the Board of Directors. Walter Van den Bossche was appointed in this function. Mr Van den Bossche also chairs Atrias's HR Committee. Mr Termont is a member of the Audit Committee at Atrias.

Atrias's financial statements are consolidated with Eandis System Operator according to the equity method.

Atrias's mission was defined as assuming the function of a central clearing house for the benefit of the DSOs and as such it is charged with the project for the development of the Message Implementation Guide (MIG) version 6, the development of a Clearing House application and the management and maintenance of this application. MIG is a data transmission protocol being used for the structured data exchange between market parties on the liberalised energy market in Belgium.

On 31 December 2016, Atrias had 20 employees (corresponding to 20.00 full-time equivalents). It has to be noted, however, that Atrias's organisation and organigram are still in evolution.

#### *Synductis*

This Eandis System Operator subsidiary was established on 21 December 2012 as a limited liability partnership ("*coöperatieve vennootschap met beperkte aansprakelijkheid*" / "*société cooperative à responsabilité limitée*") by a notarial deed of the same date, published in the Annexes to the Belgian State Gazette of 25 January 2013. Its registered office is at 9090 Melle, Brusselsesteenweg 199. The company, hereafter called "**Synductis**", is registered with the legal enterprise register of Ghent under number 0502.445.845.

The founding partners of Synductis were Eandis (930 shares – 50.0 per cent), the water company Farys (883 shares – 47.5 per cent) and the water company I.W.V.A. (47 shares – 2.5 per cent). Since the establishment date a number of other utilities have joined Synductis: the water companies I.W.V.B., Pidpa and De Watergroep; the telecom operator Proximus and the multi-utility group Infrac.

<b>Shareholder</b>	<b>Activities</b>
De Watergroep	PC
Eandis System Operator	E / G
Infrac	PC
IWVA	W / R
IWVB	W
Farys	W / R / S
Pidpa	PC
Proximus	T

#### **Legend:**

- PC: coordination of planning
- E: electricity
- G: gas
- W: water
- T: telecom
- S: sewage
- R: roads

The accounts of Synductis are being consolidated with the Issuer's accounts using the equity method.

Synductis has the vocation to better coordinate infrastructure works with an impact on the public domain. Coordination of planning and execution of infrastructure works by Synductis should lead to more synergy between utilities, minimal costs for grid operators and local authorities, and less hindrance for the population.

#### *Warmte@Vlaanderen*

This Eandis System Operator subsidiary has taken the legal form of a limited liability partnership ("*coöperatieve vennootschap met beperkte aansprakelijkheid*" / "*société cooperative à responsabilité limitée*"). It was established by a notarial deed of 18 May 2016 (notary public Mr. Anton Van Bael in Antwerp), published in the Annexes to the Belgian State Gazette of 23 May 2016. Its registered office is at 2660 Hoboken (Antwerp), Boombekelaan 14. The company, hereafter called "Warmte@Vlaanderen", is registered with the legal enterprise register of Antwerp under number 0654.826.115. It is a 50/50 joint venture with fixed capital of EUR 18,600 between Eandis System Operator (929 shares – 50.0 per cent) and Infrac (929 shares – 50.0 per cent). Walter Van den Bossche (CEO of Eandis System Operator) and Frank Vanbrabant (CEO of Infrac CVBA) have each subscribed to one share of Warmte@Vlaanderen, bringing the total number of shares to 1,860. these shares representing the fixed share capital of EUR 18,600.00.

This subsidiary was established to realize projects of district heating in the Flemish Region, with a focus on the construction, operation and maintenance of the grid infrastructure, and it not yet operational.

The first accounting year of Warmte@Vlaanderen will end on 31 December 2017.

#### *Fluvius*

This subsidiary has also taken the legal form of a limited liability partnership ("*coöperatieve vennootschap met beperkte aansprakelijkheid*" / "*société cooperative à responsabilité limitée*"). It was established by a notarial deed of notary public Kim Lagae in Brussels on 27 December 2016, published in the Annexes to the Belgian State Gazette of 3 January 2017. Its registered office is at 1030 Schaarbeek (Brussels), Koning Albert II-laan 37. The company, hereafter called "Fluvius", is registered with the legal enterprise register of Brussels under number 0668.589.227.

Fluvius is a 50/50 joint venture between Eandis System Operator (929 shares – 50.0 per cent) and Infrac (929 shares – 50,0 per cent). Piet Buyse (Chairman of the Board of Directors of Eandis System Operator) and Wim Dries (Chairman of the Board of Directors of Infrac) have each subscribed to one share of Fluvius. Fluvius's total share capital amounts to EUR 18,600.00.

The corporate objective of Fluvius is to support its shareholders, being operating companies, in developing and operating activities and developments in the organisation of grid operations, in the first place for the distribution of electricity and gas, but additionally for cable-TV and sewage systems as well. These latter activities are being operated by Infrac only, not by Eandis System Operator. Also district heating, an activity for which both operating companies have established a joint subsidiary, Warmte@Vlaanderen, is in the focus of Fluvius.

The implementation of the smart meter roll-out in the Flemish Region will be jointly organised by Eandis System Operator and Infrac in Fluvius (the so-called '*smart meter chain*'). In joining their forces, both operating companies can realise substantive synergies and cost savings, compared to a situation in which each of them would operate separately for this project.

The first accounting year of Fluvius will end on 31 December 2017.

### 2.3 *Shareholders of the Issuer*

The Guarantors are Eandis System Operator's sole shareholders. No shareholder exercises control over the Issuer. The table below reflects their exact shareholding in Eandis System Operator as at the date of this Prospectus:

	<u>shares</u>	<u>%</u>
GASELWEST .....	2,852,920	16.60%

	shares	%
IMEA .....	2,365,216	13.76%
IMEWO .....	3,853,144	22.42%
INTERGEM .....	1,881,507	10.95%
IVEKA .....	2,465,460	14.34%
IVERLEK.....	3,339,885	19.43%
SIBELGAS.....	430,972	2.51%
<b>TOTAL .....</b>	<b>17,189,104</b>	<b>100.00%</b>

All of Eandis System Operator's capital shares are ordinary nominative shares, each representing an equal share in the company's capital totalling EUR 915,124.84 (as per 31 December 2016). All shares have been fully paid up and are registered in Eandis System Operator's company share register. Each shareholder is entitled to one vote per share in the General Assembly.

Eandis System Operator has not issued profit sharing certificates.

The shareholding of the respective Guarantors in Eandis System Operator is based on the number of EAN-codes in the geographical area covered by each of the Guarantors as of the date of Eandis's constitution on 30 March 2006<sup>51</sup>. Each EAN-code represents a single physical connection to the distribution grid. As such, the number of EAN-codes is considered as a proxy to the operational activities within a certain geographical area and each of the seven Guarantors holds a participation in Eandis System Operator that is in line with its activities in the territories of its respective shareholders.

### 3. Guarantors

#### 3.1 Corporate structure

The typical corporate structure of the DSOs is outlined below. Although the Guarantors are very similar as far as their governance structure is concerned, there are some differences between them in order to meet specific local circumstances or differences in scale.

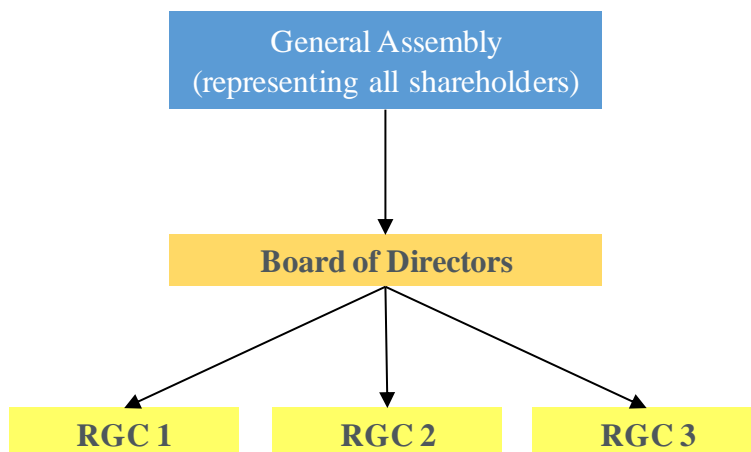

The exact number of Regional Governing Committees (named RGC in the graph above) in each DSO (2 or 3) depends on the size of the DSO.

The corporate structure above does not apply to Sibelgas. Sibelgas has, due to it being active in both the Flemish Region and the Brussels Capital Region, no Regional Governing Committees, but instead has sector committees grouping the municipalities per Region.

<sup>51</sup> The shares held by ex-IGAO were redistributed over IMEA, Intergem and IVEKA as of January 2009.



### 3.2 *Administrative regime applicable to the Guarantors*

#### *General overview and administrative review*

All Guarantors qualify as a "mission entrusted entity" ("*opdrachthoudende vereniging*" in Dutch), governed by the Flemish Decree of 6 July 2001 on the intermunicipal cooperation (the "**DIS**"), as amended by the Flemish Decree of 13 May 2016 amending several provisions of the Decree of 6 July 2001 on the intermunicipal cooperation and the Province Decree of 9 December 2005, published in the Belgian State Gazette on 17 June 2016.

Pursuant to the DIS the mission entrusted entities are subject to administrative supervision by the Flemish Government. As such the Guarantors must provide the Flemish Government with a copy or abstract summary of all its shareholders and board decisions. Decisions that breach the law, its articles of association, or the public interest may be suspended or, by decision of the Flemish government, annulled. Furthermore, the Guarantors are subject to the general principles of public law such as the principle of transparency and continuity of public service and are obliged to comply with public procurement rules. Meetings of the corporate bodies of the Guarantors are not public (with the exception of meetings of the general meeting of shareholders), but minutes must be made available at the respective municipalities to elected communal council members. Finally, the commitments entered into by the Guarantors are not commercial but of a public nature.

Mission entrusted entities have adopted the form of and follow in general rules outlined in the Belgian Companies Code for limited liability partnerships ("*coöperatieve vennootschap met beperkte aansprakelijkheid*" in Dutch / "*société coopérative à responsabilité limitée*" in French). However, on certain key points they differ from these rules; for example:

- they are established for a limited duration. In the current state of legislation the maximum duration is 18 years; a prolongation of this limited duration is possible if approved by their participants after having completed a strict approval procedure. The current termination date for all Guarantors was set at 9 November 2019 by the Flemish Decree of 25 April 2014 and their respective Articles of Association; please refer to the risk factor named "*Limited statutory duration of DSOs until 2019*" in "*Part II – Risk Factors*";
- having regard to its limited duration, the Guarantors can only enter into commitments beyond their 18 year duration to the extent (i) all measures are taken to honour these engagements and (ii) **provided that** the right for shareholders to vote against the renewal is not made more difficult or costly. The latter provision does for instance not prevent the Guarantors to contract financing or provide the Guarantees in relation to the Bonds beyond its duration (i) as these funds are used to invest in the Guarantors' assets and (ii) as upon exit these assets are partially taken back by or reimbursed to the departing shareholder(s);
- shareholders of an intermunicipal mission entrusted entity can only voluntarily exit at the end of the 18 year period if a decision is made on a possible renewal of the duration of the association. Throughout the fixed lifetime however, shareholders are prohibited to leave a DIS governed entity voluntarily;
- local authorities that are venturing into an intermunicipal company, have by rule of law transferred, for the statutory duration of the company, their relevant municipal competencies to the intermunicipal company;
- the intermunicipal companies are considered to be administrative authorities, whose decisions may be challenged before the Council of State (*i.e.* Belgium's highest administrative court, or "*Raad van State*" in Dutch and "*Conseil d'Etat*" in French).
- the intermunicipal companies are submitted to the general principles of the public service;

- the intermunicipal companies have to comply with public procurement rules and regulations that are applicable to them; and
- private entities may only hold shares in intermunicipal companies if the size of their participation does not exceed 49%.

#### *Adaptation of the articles of association of Sibelgas to comply with the DIS*

Sibelgas as a cross-regional intermunicipal entity became subject to the Flemish supervisory authority (*Toeziçthoudende Overheid*) as of 1 July 2015 and was required to adapt its articles of association by 30 June 2015 to the DIS. Sibelgas adapted its articles on 30 June 2015 but on 12 October 2015 the competent Minister decided that some of the amendments were still non-compliant with the provisions of the DIS. On 28 March 2017 Sibelgas adapted its articles to accommodate the comments of the Minister who has a period of 90 calendar days as of the change of the articles of association to accept or reject such amendments and failing such a decision the new articles will be deemed to be approved. Theoretically as Sibelgas has not adapted its articles of association in a manner that is confirmed to be compliant with the DIS, any shareholder, interested party or the competent Minister could request the Court of First Instance to dissolve this intermunicipal entity. The risk is rather remote as Sibelgas has taken the steps to adopt new articles of association and is waiting for a formal confirmation as to the compliance of these new provisions with the DIS.

#### *Non-commercial nature of the Guarantors*

It flows from the Flemish decree on Intermunicipal Cooperation that none of the Guarantors can be considered as a merchant ("*koopman*" / "*commerçant*"). As a consequence, the Guarantors are not subject to bankruptcy laws and the Bondholders will not enjoy protection of the bankruptcy laws (*ie* investors will not be able to trigger the bankruptcy of a Guarantor and thereby initiating a liquidation procedure).

#### *Immunity of execution*

The Guarantors are public law entities. Under Belgian law, such entities have the duty to perform at all times their tasks of public service (concept of the continuity of the public service). Pursuant to Article 1412bis of the Belgian Judicial Code, assets owned by a public law entity (such as the Guarantors) benefit from an immunity of execution as a result of which they cannot be seized. This immunity of execution does not apply to assets that are manifestly not useful for the performance or the continuity of the public service. This means that e.g. the distribution networks (cables and pipelines) owned by a Guarantor cannot be seized by Bondholders in case of default. Although this limits the enforceability of the obligations of the Guarantors, it also means that each of the Guarantors will be in a position to continue to perform its duties of public service and hence to generate revenues. This immunity of execution is not to be considered as an immunity of jurisdiction, i.e. the Guarantors can be brought before a court and be condemned notwithstanding this immunity. As at 31 December 2016, property, plant and equipment (which includes the value of the distribution grid infrastructure) amounted to 7,804.1 million EUR on a total asset base of 9,617.8 million EUR (IFRS figures for the Eandis Economic Group).

### 3.3 ***Board of Directors of the Guarantors***

The Board of Directors is responsible for each Guarantor's general policy decisions. Below is an overview of the directors of each Guarantor as at the date of the Prospectus – all mandates terminate on the general meeting of shareholders to be held in respect of the financial year ending 31 December 2018:

:

*Gaselwest* (business address of the directors: President Kennedypark 12, B-8500 Kortrijk)

<b>Name</b>	<b>Function</b>	<b>Other Activities (<i>inter alia</i>)</b>
Martens Luc	Chairman	Councillor of Roeselare

<b>Name</b>	<b>Function</b>	<b>Other Activities (<i>inter alia</i>)</b>
Lombaerts Piet	Vice-Chairman	Chairman of the city council of Kortrijk
Callens Karlos	Director	Mayor of Ardoois
Casier Youro	Director	Mayor of Wervik
Croes Claude	Director	Mayor of Deerlijk
Dejaegher Christof	Director	Mayor of Poperinge
Soens Rik	Director	First Alderman of Waregem
Vermeulen Jan	Director	Mayor of Deinze
Vereecke Carl	Director	Provincial Alderman of West-Flanders
Vandeputte Anne	Member with advisory vote	Councillor of Lo-Reninge

*IMEA* (business address of the directors: Merksemsesteenweg 233, B-2100 Deurne-Antwerp)

<b>Name</b>	<b>Function</b>	<b>Other Activities (<i>inter alia</i>)</b>
Kennis Koen	Chairman	Alderman of Antwerp
Geeraerts Carl	Vice-Chairman	Chairman of District Council of Antwerp
Janssens Luc	Director	Alderman of Kapellen
Dehaen Koen	Director	Alderman of Mortsel
De Meyer Sonja	Director	Councillor of the district of Merksem
Vereecken Kevin	Director	Councillor of Antwerp
Wuyts Luc	Member with advisory vote	Councillor of Duffel

*IMEWO* (business address of the directors: Brusselsesteenweg 199, B-9090 Melle)

<b>Name</b>	<b>Function</b>	<b>Other Activities (<i>inter alia</i>)</b>
Teerlinck Paul	Chairman	President "Kunstencentrum Vooruit" arts center
De Witte Peter	Vice-Chairman	Alderman of Lokeren
Annys Pablo	Director	City Councillor of Bruges
De Waele Christophe	Director	Alderman of Eeklo
Gobeyn Anneke	Director	Councillor of Maldegem
Heyse Tine	Director	Alderman of Gent
Poppe Patrick	Director	Mayor of Zele
Thienpont Filip	Director	Mayor of Merelbeke
Vandecasteele Jean	Director	Alderman of Oostende
Cornelis Franky	Member with advisory vote	Councillor of Sint-Laureins

*Intergem* (business address of the directors: Franz Courtensstraat 11, B-9200 Dendermonde)

<b>Name</b>	<b>Function</b>	<b>Other Activities (<i>inter alia</i>)</b>
Buyse Piet	Chairman	Mayor of Dendermonde
Coppens David	Vice-Chairman	Councillor of Aalst
Braems Cyntia	Director	City Councillor of Zottegem
Franceus Erwin	Director	Alderman of Geraardsbergen
Smet Ernest	Director	Councillor of Beveren
Van Duyse Kris	Director	Alderman of Stekene
Verhofstadt Henk	Member with advisory vote	Councillor of Bever

*Iveka* (business address of the directors: Koningin Elisabethlei 38, B-2300 Turnhout)

<b>Name</b>	<b>Function</b>	<b>Other Activities (<i>inter alia</i>)</b>
Diels Paul	Chairman	Mayor of Lille
Stockbroekx Ilse	Vice-Chairman	Councillor of Schoten
Jacobs Lukas	Director	Mayor of Kalmthout
Van Hove Luc	Director	Mayor of Zandhoven
Vanschoubroek Patrick	Director	Councillor of Westerlo
Verwaest Rik	Director	Alderman of Lier
Smets Dirk	Member with advisory vote	Councillor of Retie

*Iverlek* (business address of the directors: Aarschotsesteenweg 58, B-3012 Wilsele-Leuven)

<b>Name</b>	<b>Function</b>	<b>Other Activities (<i>inter alia</i>)</b>
Geypen Greet	Chairman	Alderman of Mechelen
Tobback Louis	Vice-Chairman	Mayor of Leuven
Asselman Hugo	Director	Councillor of Liedekerke
Debroeck Jan	Director	Councillor of Tienen
Desmeth Jan	Director	Alderman of Sint-Pieters-Leeuw
Hermans Dirk	Director	Councillor of Kapelle-op-den-Bos
Peeters André	Director	Mayor of Aarschot
Vermijlen Vital	Director	Chairman of the council of Bornem
Dehertog Gilbert	Director	Councillor of Overijse
Van Den Bosch Gustaaf	Member with advisory vote	Councillor of Roosdaal

*Sibelgas* (business address of the directors: Sterrenkundelaan 12, B-1210 Sint-Joost-ten-Node)

<b>Name</b>	<b>Function</b>	<b>Other Activities (<i>inter alia</i>)</b>
Andries Christian	Director	Councillor of Wemmel
Claus Johan	Director	Councillor of Vilvoorde
De Boeck Emiel	Director	Alderman of Meise
De Boeck Willam	Director	Councillor of Grimbergen
De Groef Jean-Pierre	Chairman	Mayor of Machelen
De Ridder Stefaan	Director	Councillor of Meise
Serkeyn Johan	Director	Alderman of Vilvoorde
Smets Jos	Director	Councillor of Grimbergen
Trullemans Johnny	Director	Councillor of Machelen
Van Langenhove Marcel	Director	Alderman of Wemmel

There are no conflicts of interest between the duties of directors of the Guarantors and their private interests or other duties.

#### *Regional Governing Committees*

Each DSO – with the exception of Sibelgas – has either two or three Regional Governing Committees (RGC) that have an advisory role on matters pertaining to local circumstances

The Guarantors' articles of association contain stringent provisions on corporate governance. These provisions are based on several legal and regulatory provisions as to the Guarantors' independent functioning in a liberalised energy market and the rules for a non-discriminatory access to the distribution grids for all distribution network users. In this regard, reference is made to the Flemish Energy Decree of 8 May 2009 that is strictly complied with by each of the Guarantors. Since none of the Guarantors are listed companies, the Corporate Governance Code

for Listed Companies (defined above as the "**Code**") does not apply to the Guarantors. The recommendations of the Corporate Governance Code for Non-listed Companies (also known as the Code Buisse) do apply to the Guarantors, that aim at complying with these recommendations. However, given the nature of the seven Guarantors and the fact that an extensive set of binding corporate governance rules has been imposed upon them, the Guarantors do not apply the Code Buisse in full where full compliance seems impossible, redundant or overly burdensome.

For the sake of clarity, it is to be noted that none of the Guarantors has a management committee.

### 3.4 *Shareholding of the Guarantors*

#### *General*

All capital shares of the Guarantors are currently held by local authorities (municipalities and provinces). No shareholder exercises control over any Guarantor.

The table below gives an overview of the capital of each of the Guarantors (situation on 31 December 2016).

	<b>Gaselwest</b>	<b>IMEA</b>	<b>Imewo</b>	<b>Intergem</b>	<b>Iveka</b>	<b>Iverlek</b>	<b>Sibelgas</b>
	<i>in EUR</i>						
Fixed capital .....	6,094,387.94	500,000.00	250,000.00	228,068.00	250,000.00	451,000.00	247,893.53
Variable capital .....	264,939,547.09	125,570,700.07	256,920,000.11	97,299,080.81	185,888,498.91	253,632,895.51	70,676,147.94
Total capital .....	271,033,935.03	126,070,700.07	257,170,000.11	97,527,148.81	186,138,498.91	254,083,895.51	70,924,041.47
Capital fully paid-up.	Yes	Yes	Yes	Yes	Yes	Yes	Yes

In respect of indirect shareholders, it should be noted that the local authorities - shareholders of the Guarantors - are public entities without shareholders.

The Guarantors have also issued profit certificates. For more details see the relevant tables below.

It should be noted that, in accordance with the DIS, the percentage of the shares in a Guarantor that can be held by a non-public law legal entity is capped at 49%, and without the possibility for such non-public law entity to have a decisive influence on the entity or to exercise control or a blocking power. Therefore, a change of the DIS would be required if ever the intention was to allow for such entry.

#### *Shareholding per Guarantor*

The tables below set out, for each of the Guarantors, the number of shares with voting rights attached ("**A shares**"), and the number of profit certificates ("**C certificates**") for each shareholder and for electricity and gas combined as per 31 December 2016. In Sibelgas, there are only shares with voting rights (shares "C" and "D"). There are no profit certificates in Sibelgas.

#### *Gaselwest*

<b>Shareholders</b>	<b>A shares</b>	<b>C profit certificates</b>
Alveringem.....	93,297	2
Anzegem .....	279,734	2
Ardoois .....	408,258	2
Avelgem.....	100,603	2
Celles .....	41,424	2
Comines-Warneton .....	496,962	2
Deerlijk .....	407,535	2
De Haan .....	434,454	2
Deinze .....	770,491	2
Dentergem .....	161,479	2
De Panne .....	488,130	2
Ellezelles .....	40,061	1
Gavere.....	293,347	2
Heuvelland .....	236,641	2
Horebeke .....	44,600	2
Houthulst.....	130,690	2

<b>Shareholders</b>	<b>A shares</b>	<b>C profit certificates</b>
Ichtegem.....	282,088	2
Ieper.....	1,212,509	2
Ingelmunster.....	304,347	2
Izegem.....	347,906	1
Kluisbergen.....	167,650	2
Koksijde.....	901,340	2
Kortemark.....	61,633	1
Kortrijk.....	2,644,835	2
Kruishoutem.....	257,081	2
Kuurne.....	469,257	2
Langemark-Poelkapelle.....	149,496	2
Lo-Reninge.....	64,714	2
Maarkedal.....	149,926	2
Menen.....	871,526	2
Mesen.....	27,291	2
Meulebeke.....	277,755	2
Mont de l'Enclus.....	38,644	2
Moorslede.....	227,731	2
Nazareth.....	240,727	2
Nieuwpoort.....	415,635	2
Oostrozebeke.....	199,402	2
Oudenaarde.....	852,714	2
Pittem.....	227,417	2
Poperinge.....	463,115	2
Roeselare.....	1,854,835	2
Ronse.....	843,018	2
Ruiselede.....	112,374	2
Spiere-Helkijn.....	41,297	2
Staden.....	370,316	2
Tielt.....	662,031	2
Veurne.....	406,556	2
Vleteren.....	51,849	2
Waregem.....	1,243,087	2
Wervik.....	365,768	2
Wevelgem.....	143,639	1
Wielsbeke.....	154,068	2
Wingene.....	373,651	2
Wortegem-Petegem.....	134,166	2
Zingem.....	145,008	2
Zonnebeke.....	276,158	2
Zulte.....	349,539	2
Zwalm.....	146,414	2
Zwevegem.....	423,786	2
<b>Total municipalities.....</b>	<b>23,380,005</b>	<b>114</b>
Province West-Flanders.....	8	2
<b>Total.....</b>	<b>23,380,013</b>	<b>116</b>

*Imea*

<b>Shareholders</b>	<b>A shares</b>	<b>C profit certificates</b>
Antwerpen.....	9,758,086	2
Brasschaat.....	1,271,997	2
Duffel.....	674,692	2
Kapellen.....	460,399	2
Mortsel.....	665,952	2
Zwijndrecht.....	566,773	2
<b>Total.....</b>	<b>13,397,899</b>	<b>12</b>

*Imewo*

<b>Shareholders</b>	<b>A Shares</b>	<b>C Profit Certificates</b>
Aalter.....	312,017	2
Assenede.....	214,025	2

<b>Shareholders</b>	<b>A Shares</b>	<b>C Profit Certificates</b>
Beerlem	213,111	2
Berlare	183,877	2
Blankenberge	390,645	2
Bredene	221,236	2
Brugge	2,342,080	2
Damme	149,534	2
De Pinte	128,133	2
Destelbergen	293,082	2
Eeklo	520,139	2
Evergem	653,639	2
Gent	7,331,085	2
Jabbeke	83,641	1
Kaprijke	103,562	2
Knesselare	120,290	2
Knokke-Heist	996,128	2
Laarne	194,544	2
Lede	245,791	2
Lichtervelde	132,010	2
Lochristi	396,492	2
Lokeren	710,437	2
Lovendegem	170,701	2
Maldegem	406,322	2
Melle	215,491	2
Merelbeke	349,141	2
Moerbeke-Waas	111,599	2
Nevele	185,026	2
Oostende	1,596,480	2
Oosterzele	169,872	2
Oostkamp	300,577	2
Sint-Laureins	111,111	2
Sint-Lievens-Houtem	127,732	2
Sint-Martens-Latem	121,806	2
Waarschoot	136,769	2
Wachtebeke	76,236	2
Wetteren	506,127	2
Wichelen	161,211	2
Zedelgem	289,055	2
Zeile	464,509	2
Zomergem	107,306	2
Zuienkerke	43,341	2
<b>Total municipalities</b>	<b>21,585,910</b>	<b>83</b>
Province West-Flanders	2	2
<b>Total</b>	<b>21,585,912</b>	<b>85</b>

*Intergem*

<b>Shareholders</b>	<b>A Shares</b>	<b>C Profit Certificates</b>
Aalst	1,804,044	2
Affligem	140,406	2
Bever	15,149	2
Beveren	1,045,681	2
Brakel	148,307	2
Buggenhout	259,186	2
Denderleeuw	276,315	2
Dendermonde	1,031,199	2
Erpe-Mere	263,809	2
Geraardsbergen	523,809	2
Haaltert	234,323	2
Hamme	452,502	2
Herzele	185,368	2
Kruikebeke	284,509	2
Lebbeke	305,691	2
Lierde	59,326	2
Ninove	623,721	2
St.-Gillis-Waas	317,541	2
St.-Niklaas	1,730,602	2
Stekene	297,607	2

<b>Shareholders</b>	<b>A Shares</b>	<b>C Profit Certificates</b>
Temse.....	581,820	2
Waasmunster .....	152,683	2
Zottegem .....	386,664	2
<b>Total</b> .....	<b>11,120,262</b>	<b>46</b>

*Iveka*

<b>Shareholders</b>	<b>A Shares</b>	<b>C Profit Certificates</b>
Aartselaar .....	186,538	1
Arendonk.....	312,667	2
Baarle-Hertog .....	58,284	2
Balen.....	401,227	2
Beerse .....	429,516	2
Boom .....	295,218	2
Borsbeek .....	142,744	2
Brecht.....	606,850	2
Dessel.....	220,297	2
Edegem.....	323,482	2
Essen.....	90,698	1
Geel .....	888,272	2
Grobbendonk .....	172,285	1
Herentals .....	712,801	2
Herenthout.....	222,919	2
Hoogstraten .....	547,601	2
Hove .....	147,465	2
Kalmthout.....	413,108	2
Kasterlee .....	414,917	2
Kontich .....	455,052	2
Lier .....	790,244	2
Lille .....	428,311	2
Lint .....	124,797	2
Malle.....	387,134	2
Meerhout .....	226,453	2
Merksplas .....	70,961	1
Mol .....	812,543	2
Olen .....	286,895	2
Oud-Turnhout .....	332,066	2
Ranst.....	429,477	2
Ravels .....	382,929	2
Retie.....	261,558	2
Rijkevorsel .....	304,186	2
Rumst.....	355,175	2
Schelle.....	169,887	2
Schilde .....	472,167	2
Schoten .....	656,964	2
Stabroek .....	158,677	1
Turnhout.....	933,460	2
Vorselaar .....	55,870	1
Westerlo .....	582,113	2
Wijnegem.....	213,084	2
Wommelgem .....	296,193	2
Wuustwezel .....	464,794	2
Zandhoven.....	309,681	2
Zoersel .....	455,997	2
<b>Total</b> .....	<b>17,003,557</b>	<b>86</b>

*Iverlek*

<b>Shareholders</b>	<b>A Shares</b>	<b>C Profit Certificates</b>
Aarschot.....	807,670	2
Asse .....	799,309	2
Beersel .....	749,435	2
Berlaar.....	318,921	2
Bertem.....	222,760	2



Shareholders	A Shares	C Profit Certificates
Bierbeek .....	230,142	2
Bonheiden .....	389,769	2
Boortmeerbeek .....	257,329	2
Bornem .....	579,744	2
Boutersem .....	171,570	2
Diest .....	213,666	1
Dilbeek .....	1,093,434	2
Drogenbos .....	202,120	2
Haacht .....	309,336	2
Halle .....	1,040,978	2
Heist-Op-Den-Berg .....	1,031,259	2
Herent .....	517,086	2
Herselt .....	336,516	2
Hoegaarden .....	187,292	2
Hoeilaart .....	295,786	2
Huldenberg .....	209,400	2
Hulshout .....	242,023	2
Kapelle-Op-Den-Bos .....	213,514	2
Keerbergen .....	234,871	2
Kortenberg .....	549,744	2
Kraainem .....	391,004	2
Lennik .....	220,212	2
Leuven .....	3,023,846	2
Liedekerke .....	293,814	2
Linkebeek .....	160,190	2
Londerzeel .....	392,568	2
Mechelen .....	2,810,303	2
Merchtem .....	361,786	2
Opwijk .....	279,236	2
Overijse .....	716,641	2
Putte .....	402,940	2
Puurs .....	481,630	2
Roosdaal .....	258,444	2
Rotselaar .....	369,352	2
Scherpenheuvel-Zichem .....	508,869	2
Sint-Amands .....	204,394	2
Sint-Genesius-Rode .....	535,487	2
Sint-Katelijne-Waver .....	600,152	2
Sint-Pieters-Leeuw .....	969,266	2
Ternat .....	386,158	2
Tervuren .....	617,655	2
Tienen .....	1,087,554	2
Tremelo .....	184,414	2
Wezembeek-Oppem .....	392,435	2
Willebroek .....	811,615	2
Zaventem .....	1,242,561	2
Zemst .....	538,504	2
<b>Total .....</b>	<b>29,444,704</b>	<b>103</b>

### *Sibelgas*

Shareholders	C Shares	D Shares
Anderlecht .....	1	0
Brussel .....	2	0
Evere .....	2	0
Ganshoren .....	2	0
Grimbergen .....	2	2,826
Jette .....	2	0
Machelen .....	2	1,692
Meise .....	2	1,238
Sint-Joost-Ten-Node .....	2	0
Schaarbeek .....	2	0
Vilvoorde .....	2	3,116
Wemmel .....	2	1,128
T.G.E.K. .....	3	0
R.D.E. ....	4	0
I.B.E. ....	1,790,033	0

Shareholders	C Shares	D Shares
I.B.G. ....	1,474,319	0
<b>Total public authorities</b> .....	<b>3,264,382</b>	<b>10,000</b>

### *General Meeting*

Twice a year the General Meeting is convened: in the course of the first semester for discussing and approving the annual financial statements of the previous financial year, and in the course of the second semester for a discussion on the budgets and the strategy for the following year.

### 3.5 *The exit of Electrabel from the share capital of the Eandis Economic Group*

The DIS required private company Electrabel NV (part of the French utility group Engie) to exit from the Guarantors at either (i) the occasion of a DSO's renewal of its statutory duration or (ii) on 31 December 2018 at the latest. In order to adequately anticipate this legal obligation, negotiations were started in the course of 2013 with the aim to realise an accelerated and general 'exit' of Electrabel from all the Guarantors, as well as the parallel exit of the public sector from Electrabel Customer Solutions, an affiliate of Electrabel active in electricity supply.

Hence, on 27 August 2014 Electrabel and the Guarantors reached a principle agreement on Electrabel's exit as a shareholder of the Guarantors by the end of 2014. The parties agreed that in parallel the exit of the public sector from Electrabel Customer Solutions (ECS) would be organised. Both transactions were to be realised through a sale of shares. Only the exit of Electrabel from the share capital of the Guarantors affects the Eandis Economic Group (as, at that moment, Electrabel owned 21 per cent non-voting shares in the Guarantors and had not appointed any board members). The parallel transaction involving Electrabel Customer Solutions did not affect the Eandis Economic Group.

The preferred simultaneous exit, instead of a gradual departure between 2014 and 2018 as required by law, clearly simplified the operation and enhanced the transparency in the energy market. The principle agreement between Electrabel and the Guarantors was approved by the Guarantors' and ECS's shareholders during the period September-December 2014. Closing and payment of this sale of shares by Electrabel and the purchase of these shares by the Guarantors' public shareholders took place on 29 December 2014.

Electrabel's exit did not have any impact on the day-to-day operational activities of the Guarantors.

### 3.6 *Aborted merger and entry of private investor*

At the end of 2015 the Guarantors envisaged to merge into one entity with the largest Guarantor, Gaselwest (to be renamed as "Eandis Assets" and to become the absorbing entity). The merger was approved by a series of resolutions of the general meeting of shareholders of the Guarantors between 9 December 2015 and 30 December 2015, with each of these resolutions subject to a series of conditions precedent such as *inter alia* (i) the amendment of the DIS to allow a private partner to enter into the capital of Eandis Assets, (ii) the repositioning of the 5 Walloon municipalities of Gaselwest in a separate operational and legal entity Gaselwest-Zuid and (iii) the written confirmation by the VREG that the differentiated tariffs in the geographical zones of the Guarantors could be maintained following the merger.

Simultaneously, as from July 2015 onwards, Eandis started an auction process to search for a new private partner which would become a 14% minority shareholder in the capital of the new merged entity Eandis Assets. On 29 June 2016, Eandis announced that it had signed a shareholders' and subscription agreement with State Grid International Development Ltd ("**State Grid**"), a wholly-owned subsidiary of State Grid Corporation of China to become a shareholder in Eandis Asset for a new equity stake of 14%. Its entry was subject to a number of conditions precedent, in particular the approval and completion of the merger by the Guarantors.

However, at an extraordinary shareholder meeting on 3 October 2016, the Issuer and the Guarantors announced that the merger could not be concluded due to two conditions precedent

not being fulfilled. Firstly, four Walloon municipalities had not been successful in setting up their own operational entity and remain members of Gaselwest. Secondly, Imea concluded that, based on a statement by the VREG, its requirement for maintaining differentiated tariffs in the geographical zones following the merger for a sufficiently long period, i.e. at least until 2020, could not be fulfilled. This in turn prevented the planned entry of State Grid as a new shareholder for a 14% stake in Gaselwest (to be renamed as "Eandis Assets"). In addition, a EUR 100 million capital increase, received from the intermunicipal financing associations in July 2016 as part of the merger and recapitalisation of the business, had to be reversed and was repaid in December 2016.

For the sake of clarity: the aforementioned transaction would only have impacted the Guarantors and their shareholders, without impacting the Issuer's financial position.

#### 4. **Legal and arbitration procedures**

##### 4.1 ***Legal and arbitration proceedings of the Issuer***

###### *Legal Proceedings*

The Issuer is currently involved in litigation about an industrial accident involving one of its employees. On 7 July 2015, the said employee was severely injured during an intervention on the electricity grid. After an investigation carried out by the supervisory inspector for well-being on the workplace, the labour auditor decided to bring the employee's employer Eandis System Operator before the Criminal Court for a number of shortcomings in relation to the Law on well-being (4 August 1996) and the Royal Decree of 4 December 2012 on the minimal safeguards with electric installations in the workplace<sup>52</sup>. The Criminal Court ruled on 5 April 2017 that all allegations were proven and condemned the Issuer to a financial penalty of EUR 18,000, half of which with a suspension of 3 years. The parents of the victim each received EUR 10,000 (plus interests, and litigation costs of EUR 1,320). The victim's sister was awarded EUR 5,000 (plus interests, and litigation costs of EUR 1,080).

Due to the fundamental nature of the arguments brought forward in this case for its operational activities, the Issuer is currently contemplating to lodge appeal in this case before the Court of Appeal. A ruling of this Court, if an appeal is lodged, is not expected before the end of the year 2017.

###### *Insurance Proceedings*

Eandis System Operator is currently not involved in insurance proceedings that could have a material impact on it.

###### *Provisions*

There are no provisions relating to the outcome of any such proceedings in the consolidated financial statements of the Issuer for the financial year ended on 31 December 2016.

##### 4.2 ***Legal and arbitration proceedings of the Guarantors***

###### *Legal Proceedings*

The summary below gives an overview of the proceedings that may have a material impact on one or more of the Guarantors.

- *Distribution grid user/prosumer vs DSOs Iverlek and Electrabel*: a natural person who qualifies as a Prosumer connected to the distribution grid of DSO Iverlek (which is one of the Guarantors), brought both DSO Iverlek and his electricity supplier Electrabel (since 1 April 2016 Electrabel Customer Solutions) before the Court of Commerce in Brussels. Claimant claims the repayment of all sums already paid by him as prosumer

---

<sup>52</sup> Although it is clear that this accident was caused by human errors, no natural persons were brought before the Court, but only the legal entity Eandis System Operator.

tariff. (budgeted at EUR 1,096.24). This specific access tariff due by prosumers which own solar panels with a capacity equal to or below 10 kW, was introduced by decision of the energy regulator VREG (BESL-2014-35) and billed by Iverlek since 1 July 2015. On 9 March 2017, the said Court ruled that the claim was unfounded and the Court ruled itself incompetent to assess the validity of the prosumer tariff. At the date of this Prospectus, it is not yet clear whether the claimant will file appeal against the ruling by the Court of Commerce of Brussels.

- *Litigation on prosumer's tariff*: the prosumer's tariff (as part of the tariff decisions taken by the Flemish energy regulator VREG at the end of the year 2014) was also brought before the Brussels Court of Appeal and the Council of State by Zon, straal vzw. In, an interlocutory judgment, the Court of Appeal has ruled on its competency, but at the same time indicated that the Council of State should also rule on the competency in this specific matter. Up to the date of this Prospectus, the Council of State has only ruled on the appeal for suspension. A ruling by the Council of State on the substantive issues is still being awaited. Whatever the outcome of this litigation, the DSOs will be able to process the possible financial impact through their tariffs.
- *DSOs – fraud with green certificates*: the federal crime unit has investigated a case of large-scale fraud with green power certificates by a number of companies. Both the Guarantors and the Issuer, who have asked for the status of aggrieved party in this case, have been heard as a witness in the course of the investigations. It should be pointed out that the Issuer had already paid approx. EUR 8 million to the companies under investigation, which might turn out to be based on false allegations by the companies. If the amount paid can be fully or partially recovered, this will not negatively impact the financial accounts of either the Guarantors or the Issuer, since the amounts recovered will be passed through to the distribution grid tariffs.
- *DSOs – case brought by Essent Belgium NV*: the Guarantors are involved in a proceedings regarding the promotion of environmental-friendly electricity through the free distribution of green energy as described in more detail below *Compatibility of the Flemish green certificates Scheme with EU law* in section 6.10 below. The proceedings were initiated by the supplier Essent Belgium NV against the Flemish Region; the Guarantors and the DSOs of the Infrax-group, as well as the Flemish energy regulator VREG, have voluntarily intervened in these proceedings. Essentially, Essent disputes the decisions of the Flemish Government which only accept the certificates from electricity producers in Flanders, as the current scheme provides that only green energy produced within the Flemish Region's territory is ineligible for green energy certificates. The Guarantors intervened as defendant, because the grid operators in the Flemish Region had billed the claimant (February and April 2005) for a total amount of EUR 3.5 million for costs related to the distribution of green power generated by Essent<sup>53</sup>, based on the Flemish Decree of 24 December 2004. It should be noted that the European Court of Justice (ECJ) delivered a judgment on 1 July 2014<sup>54</sup>, which can be interpreted as supporting the defendants' arguments. In line with this decision in the aforementioned case, the Court of Justice subsequently rendered a judgment in the Essent case on 11 September 2014<sup>55</sup>. The Flemish support scheme is compatible with the principle of free movement enshrined in the EU Treaty. After the ECJ's judgment the debates in the Essent proceedings before the Belgian Court of First Instance were reopened. In an interlocutory judgment the Court of First instance submitted a prejudicial question to the ECJ. The latter held a pleading session on 21 September 2016. The parties involved are now awaiting the advice by the Advocate-General and the ECJ's judgment, after which

---

<sup>53</sup> For the sake of clarity: this amount is the total amount for all Flemish DSOs, i.e. the aggregate amount billed by the Guarantors and the Infrax-DSOs.

<sup>54</sup> Judgment of the Court (Grand Chamber) of 1 July 2014 in the case "Ålands vindkraft v Energimyndigheten" [case C-573/12] as described in more detail in section *Compatibility of the Flemish Green Certificates Scheme with EU law*, on page 110.

<sup>55</sup> Judgment of the Court (4th Chamber) of 11 September 2014 in the joined cases C-204/12 to C-208/12 "Essent Belgium NV v VREG".

the Court in Brussels will have to reassess the case. The DSOs have consistently taken a passive stance in these proceedings, since the Flemish Region is the more relevant party.

### *Insurance Proceedings*

In the course of their normal activities the Guarantors are confronted with a large number of insurance proceedings that are separately not material, but taken all together could have a material impact. In the following table an aggregated overview (situation as per end December 2016) of the disputed files in which at least one of the Guarantors is involved is presented (note: not all of the disputes listed below have led or will lead to a legal proceedings, many of them being settled amicably by agreement between the DSO and the end user):

<b>Type of claim</b>	<b>Number of claims</b>	<b>Potential financial impact (EUR)</b>
Works carried out for the account of the customer <sup>56</sup> * .....	2,913	2,886,601
Professional drops <sup>57</sup> * .....	1,056	1,041,800
Residential drops <sup>58</sup> * .....	552	1,240,759
Final invoice "Move Outs" <sup>59</sup> * .....	4,997	5,817,748
Final invoices "Social Public Service Obligations" <sup>60</sup> * .....	280	875,780
Fraud * .....	910	1,679,731
Damages to DSO network infrastructure * .....	737	1,530,108

As to the specific topic of grid infrastructure displacements, the Issuer (on behalf of the DSOs) is currently (i.e. as per 31 December 2016) involved in a number of cases with Infrabel NV, the Belgian railroad infrastructure manager, both as a claimant and as a defendant. The Issuer is claiming an amount of EUR 1,063,649 (including interests, costs of proceedings and legal costs, this amounts to EUR 1,274,700). On the other hand, Infrabel NV is claiming from Eandis System Operator an amount of EUR 868,847 (including interests, costs of proceedings and legal costs, the claim amounts to EUR 1,263,129).

The Flemish Region is claiming EUR 92,714 from the Issuer for displacements.

Taking into account all claims by and on the Issuer for displacements as per 31 December 2016, the Issuer is claiming on balance EUR 7,218. These costs can be included in the tariffs.

It is to be noted that for all proceedings marked by an asterisk (\*) in the above table, financial payments made by the Guarantors can be entirely passed through into the tariffs and should thus not have a negative financial impact on the Guarantors.

On an aggregate basis, the Guarantors were involved in 180 civil liability files with total claims of EUR 9,736,572.38 on 31 December 2016. However, the Guarantors have taken insurance cover for civil liability. The cover provides for a limitation of the Guarantors risk of EUR 7,500 per case, limiting the current total maximum civil liability for the seven Guarantors to EUR 1,350,000.

<sup>56</sup> Invoices sent for collection to collecting agency or lawyer.

<sup>57</sup> Professional drop: termination by a supplier of a supply contract with a non-residential customer – if no new supplier has been contracted within 30 days the DSO has to suspend energy delivery. The number of cases reported reflects the cases in which the DSO has to legally close down the access.

<sup>58</sup> Residential drop: termination by a supplier of a supply contract with a residential customer – if no new supplier has been contracted within 60 days the DSO has to take over the energy delivery. The number of cases reported reflects the cases in which the DSO has to legally close down the access.

<sup>59</sup> Energy bills for supplies delivered to access points for which the last known end user has correctly terminated the supply contract and for which no new end user has been identified; these energy bills are presented to the owner of the premises or to the new tenant. The number of cases reported reflects the cases in which the DSO has to legally close down the access.

<sup>60</sup> Energy bills for access points for which the last known end user was supplied by the DSO according to the social public service obligations. The number of cases reported reflects the cases in which the DSO has to legally close down the access.

On the other hand, the DSOs themselves are claiming an aggregate amount of EUR 2,499,429.33 from third parties relating to damages caused by these third parties to the distribution infrastructure owned by the DSOs. This concerns a total number of 867 proceedings.

#### *Provisions*

There are no provisions relating to the outcome of any such proceedings in the consolidated financial statements of the Eandis Economic Group for the financial year ended on 31 December 2016.

### **5. Significant changes in the financial or trading position of the Issuer and the Guarantors**

#### **5.1 Significant changes in the financial or trading position of the Issuer**

##### *Trend information*

There has been no significant change in the financial or trading position of the Issuer since 31 December 2016 and no material adverse change in the Issuer's prospects since 31 December 2016.

#### **5.2 Significant changes in the financial or trading position of the Guarantors**

##### *Trend information*

There has been no significant change in the financial or trading position of the Guarantors since 31 December 2016 and no material adverse change in the Guarantors' prospects since 31 December 2016.

### **6. Trends in the market in which the Issuer and the Guarantors are active**

#### **6.1 Strategic response to trends**

In working out the strategic options for the Issuer, the Board of Directors and the management of the Issuer carefully consider all relevant policy measures taken by the Flemish government and the competent energy regulator, as well as the changing economic and technical realities in Eandis's working context. Eandis System Operator is always careful, however, not to compromise the current reliability and the quality of the energy grid by implementing policy changes. It therefore considers every implementation option on its financial, technical and logistical feasibility and reassures itself that any strategic choice made should be socially acceptable to grid users. A second foundation for outlining the mid-term strategic options is evidently the company's mission, vision, strategy and values, as approved by the Board of Directors. The strategy consists of five pillars: (1) compliance, (2) performance, (3) customer oriented, (4) organization oriented and (5) learn & grow. For each of these domains, strategic actions have been outlined:

- *Compliance:*
  - the creation of a broad support base for the introduction of smart metering and its segmented roll-out; one way to realize this is by offering smart metering on demand;
  - a proactive approach towards the regulator and the stakeholders as to the tariff framework;
  - the creation of a broad support base for the use of flexibility as a means to manage congestion on the distribution grids.
- *Performance:*
  - For performance, three strategic axes have been defined, notably (i) an active contribution to the efficient operation of the energy market, (ii) cost reduction as

a contribution to an equitable grid tariff and (iii) creating a margin of operation through non-regulated activities;

- An efficient market operation can be enhanced by implementing MIG-6 (Message Implementation Guide) as the protocol for data exchanges in the energy market. The subsidiary Atrias is working on this on behalf of all Belgian distribution grid operators. On top of this, Eandis System Operator wants to offer data services thus enabling new businesses (flex, energy service companies etc.);
- Cost reduction has been embodied in the company-wide FIT and Breakthrough FIT efficiency programmes (see p.99);
- Eandis System Operator has outlined a number of non-regulated activities which it believes have the potential to create margin. This idea was further elaborated in 4 so-called 'spin-ins': (i) telecom activities, based on the fibre grid already operated by the Issuer, (ii) 'vertical infrastructure', i.e. offering services to third parties on the basis of existing infrastructure elements of the distribution grids (public lighting poles, etc.); (iii) starting up 'asset management' for third parties, which can consist of operating grids owned by third parties and (iv) consulting in the field of asset management, asset analytics etc. Eandis's global purchasing approach will be screened and put into a larger perspective. If efficiency gains can be detected, the necessary changes to the purchasing procedures will be implemented. The principle of 'Total Cost of Ownership' will be reinforced;
- *Customer oriented:*
  - Eandis System Operator will continue to put a lot of effort to execute all of its customer-oriented activities according to the basic principle of operational excellence. These activities include a.o. the best possible repair of roads and pavements after infrastructural works, the throughput time for connections and other technical interventions, activities with regard to the (social) public service obligations and the rational use of energy and others. The Issuer makes use of a set of business indicators to follow up on the actual results on the parameters for customer satisfaction.
- *Organisation oriented:*
  - For the Issuer, the continuous and systematic improvement and streamlining of its business processes remains a top strategic priority. With the support of a high-quality IT-system and - for asset management processes - guided by the principles enshrined in ISO 55001 normative guidelines, the Issuer wishes to implement robust and highly efficient business processes;
  - Overall safety for humans and infrastructure, and environmental care are and remain at the heart of what the Issuer does. A Global Prevention Plan 2015-2019 and a Global Environmental Plan 2015-2019 are in the midst of being implemented through dedicated annual plans, both for safety and environmental care. A wide range of business indicators (such as the frequency and severity of industrial accidents, ecological footprint, number of environmental incidents) allow management to accurately steer these two processes;
  - Eandis System Operator wishes to collaborate with third parties in partnerships. Its subsidiaries Synductis, Warmte@Vlaanderen and Fluvius have recently been established with this specific aim. These initiatives will be reinforced wherever and whenever this is worthwhile from an economic and/or societal point of view. A cooperation with interested partners might also be set up in the field of Fibre-to-the-Home (FTTH).

- A complete integration with the Issuer's peer company Infrac is on the agenda and will allow for further cost efficiencies and a stronger market position for both groups (please see section 8 below for further detail on this point).
- *Learn & grow:*
  - In a fast-moving technological and regulatory context, the Issuer has the ambition to develop its own organisation and employees with these challenges in mind. Therefore, the Issuer will maintain its efforts for training and developing new competences. Special attention will be paid to the areas of big data, state-of-the-art asset management, flexibility, balancing and congestion management;
  - The Issuer is fully aware of the energy transition currently taking shape. That is why the Issuer has defined the promotion and implementation of energy efficiency, especially geared towards the local authorities as its natural partners, as one of its strategic priorities. The offering of energy services for local authorities remains one of the most visible aspects of this offering.

The five strategic pillars are complemented by four value propositions which can be considered to be the DNA of the company:

- manage grids in a safe, cost-efficient and reliable way;
- as an independent data manager, promote the smooth functioning of the energy market;
- as a Flemish expertise centre for energy, contribute to the climate objectives;
- reduce energy poverty in collaboration with all parties concerned.

#### *Strengthening the Core Business*

Based on the results of an extensive analysis the Issuer's Board of Directors has chosen for the strategic option not to engage in other activities such as the water distribution or sewage systems (but note that, following the complete integration with Infrac, the expectation is that the current activities of Infrac in sewage, cable distribution and public lighting, and the activities in district heating that are currently being developed, will continue to be developed). In the opinion of Eandis System Operator, synergies between its own activities and the aforementioned and other utilities can best be realised in the form of cooperation. The Synductis initiative is an illustration of this approach.

Eandis System Operator prefers the continued reinforcement of an excellent service delivery to shareholders and network users alike through strengthening its own core business, i.e. the distribution of gas and electricity. Synergy in operations on the public domain is perfectly in line with Eandis's policy of minimising hindrances and maximizing cost efficiency.

#### 6.2 *Trends identified in the Flemish approach to energy distribution*

The Flemish Parliament and the Flemish Government have over the years outlined a number of ideas on energy policy. These ideas can be summarised as follows:

- *Energy efficiency and ancillary measures.* On the back of European objectives, the Flemish Region will keep focusing on energy efficiency, in order to reduce energy consumption bills and to reach the climate objectives – the transition towards a new energy system will be prepared. Carbon emissions reducing measures will be intensified and residential energy consumers should in the future be able to adapt their energy demand to the actual energy cost at different points in time during the day. Finally, the fight against energy poverty will be intensified and the cooperation in this matter between the DSOs, the Public Centres for Social Welfare and other parties such as the social economy will play a central role therein, as was already the case in the past.



- *Renewable energy support.* The certificate system for green power and CHP will be kept in place. However, the system has already been and will perhaps further be adapted in order to safeguard its viability and economic relevance.
- *Re-Structuring of the sector.* Recent political developments have brought the ongoing discussions on the structures of the energy distribution sector in Flanders to the forefront. The would-be structure of the sector cannot be seen separate from the discussion on the optimization of the distribution grid tariffs and the overall consumption price of electricity and, to a lesser extent, gas for the end consumers in Flanders. It cannot entirely be ruled out that current developments lead to far-reaching changes in the overall distribution sector's structure and organisation, such as a merger (or similar restructuring) of the operating companies Infrax and Eandis System Operator (whether or not in their joint affiliate Fluvius, a merger of some or all of the Guarantors or of some or all Flemish DSOs, or the decision to have the Issuer (or a merged entity consisting of the Issuer and Infrax) listed on a stock exchange. It is also possible that the range of activities to be carried out by the Guarantors and/or their operating company, which is the Issuer, will be more restricted or wider in the future.
- *Flemish regulatory framework for future tariffs.* The VREG, the DSOs and the Flemish Government and Flemish Parliament will continue their work to prepare for a fundamental change in the tarification principle. In the recent past, the Flemish Government has already urged for the distribution tariffs to be transformed into "purely grid-related tariffs per target group reflecting the capacity reserved by a customer". Tariffs should be cost reflective and integrate objective differences (e.g. grid density in urban and rural areas). The switch towards a (partial) capacity-driven tarification mechanism for the Flemish energy distribution sector will, however, take a substantial preparation period.

### 6.3 *Trends in the energy sector*

The energy sector worldwide, as well as in Europe and Belgium, is faced with a number of major challenges. These can be summarised in one single concept: the "energy transition". This concept is about the switch from a fossil-fuel based centralised, predictable electricity system towards a decentralised system in which intermittent and thus largely unpredictable and unreliable renewable energy sources play a vital role. As a consequence, the energy transition poses a number of technical challenges, in particular concerning the flexibility and stability on the distribution grids. Apart from this, the consumer will demand more involvement for himself: he will of course remain a consumer, while at the same time he will also become a producer (solar, microgrid, ...) and energy storage player (electric cars, home batteries, etc.).

The Issuer has identified a number of general trends in the energy sector. These can be summarised as follows:

1. The DSOs (and their operating companies) should be able to evolve towards a (partially) capacity-driven tarification; this tarification reflects the development of the grid into an 'insurance' for which an annual 'insurance premium' is due, based on the capacity of the connection to the grid;
2. DSOs and operators should tap into the full array of possibilities of a smart grid. It is widely expected that grid management will change from an asset-driven activity into a data-driven one. Data, some even real-time or quasi real-time, on consumption and consumption patterns, flexibility, grid balance, installed capacity, etc will allow grid operators to better manage bi-directional energy flows on their grids, to reduce grid losses and to realise energy savings;
3. Integrated grid management: grid operators will have to explore synergies with other utilities;
4. Evolutions in the energy demand: changes in the energy mix with increasing electrification (electric mobility, electric heat pumps and others) and a decrease in gas consumption;

5. Evolutions in energy production: more decentralized electricity and heat generation and 'green gas' production;
6. Evolutions in managing demand and supply; centralized and decentralized supply and demand management – new players in an adapted market model;
7. Evolution in grid management: off-grid initiatives, micro grids and new technological advances in grid management.

In addition, at the end of 2016 the European Commission launched a major package of legislative reforms aimed at progressing its plans for an Energy Union including recasts of the Third Electricity Directive and the Electricity Regulation<sup>61</sup> (the "**Winter Package**"). This legislative package will further empower consumers. In addition, the Agency for the Cooperation of Energy Regulators (ACER) will need to issue a recommendation on "the progressive convergence of transmission and distribution tariff methodologies" by 2019. Moreover, the distribution grid tariffs will amongst others need to take into account the costs generated by "active consumers" and where possible implement time differentiated tariffs to cater for the installation of smart meters. Finally, the Winter Package envisages to establish a "European Entity for DSOs" responsible for *inter alia* the integration of renewables, the development of demand-side response, the deployment of smart grids, data management and specific cooperation with ENTSO-E (the European Network of Transmission System Operators for Electricity). The Winter Package's proposals need to follow the normal legislative procedure before becoming binding European legislation and this is expected at the earliest in the second half of 2018.

#### 6.4 *Decentralised Electricity Generation*

Eandis System Operator has to cope with the steady increase in the number of installations for decentralised electricity generation (solar modules, CHP, wind turbines and others) that are or have to be connected onto the distribution grid. This puts pressure on the traditional design of the electricity distribution grid. Since more and more end users inject electricity into the distribution grid themselves - rather than only be an off taker of electricity – the distribution network design needs to reflect and cater for a bidirectional use of the distribution network. This trend has also impacted the volumes of electricity being transported over the DSOs' distribution grids. Eandis System Operator has noted that the spectacular growth rate in the number of photovoltaic installations has recently somewhat decreased, partly as a result of the limitation in the subsidy mechanisms allowed for by the Flemish Government. Nevertheless, it is expected that the rise in solar generation capacity, directly connected to the distribution grid, will continue for the foreseeable future, also supported by an active promotion campaign by the Flemish authorities. Insufficient investments in electricity distribution grids, however, might lead to insufficient capacity on these distribution grids, associated with higher risks for fall-outs, grid disturbances and a lower quality of electricity delivery.

Another important evolution is the development of offshore wind farms in the Belgian part of the North Sea. This will entail considerable investments, especially at the level of the transmission grid operated by Elia System Operator NV, but will most certainly also have a fall-out on the distribution grids operated by Eandis System Operator.

Eandis System Operator wants to be ready for these developments, both by planning and budgeting for the required grid modifications, as well as executing them. It has developed the following lines of action:

- Consult the competent authorities in order to analyse the use and impact of stimuli for optimal geographic location of large decentralised generation facilities with a view to minimising electricity grid expansion costs;
- Pro-active investments in the electricity grid where it is possible to estimate the future levels of decentralised generation;

<sup>61</sup> Regulation (EC) No. 714/2009 of the European Parliament and the Council of 13 July 2009 on conditions for access to the network for cross-border exchanges in electricity and repealing Regulation (EC) No 1228/2003

- A step by step evolution of the electricity distribution grid towards a smart grid, in which important investments in the mid voltage networks will be required in the short term to enable control of the energy flow direction. In the medium term, the realization of a smart grid will require investments to enable real time data collection. Expansive metering will allow for a better manipulation of energy flows, or a so-called "smart grid". The planning, phasing and realization thereof is the subject of a study that will lead to an investment decision.

Eandis System Operator is currently assessing the investments needed in the years beyond 2017. Its long term investment plans will be updated accordingly. Investments by Elia System Operator NV, the electricity transport system operator, will have a direct impact on this assessment since such investments can directly trigger additional investments in the distribution grid.

Logically, and as explained in section 3.5 in "*Part VIII - Regulatory Framework Applicable to the Flemish DSOs*", investments in the distribution grid will impact the distribution grid fee. Also, the increased costs will be distributed over smaller distributed volumes of energy since production of electricity is expected to happen in a much more decentralised way. Eandis will closely monitor the impact of these evolutions on the overall distribution grid fee and will analyse and propose options to reduce sudden increases in the grid fees. To this end, the granting of financial stimuli for projects that only need marginal investments for connection to the distribution grid, could be one way of incentivising efficient investments in decentralised electricity generation aiming at bringing distribution grid fees down.

#### 6.5 *Smart Meters, the Market Model and Data Management*

Metering and the management of metering data is a crucial task in the organisation of liberalised energy markets. A more pronounced competition in the energy markets and the drive towards more energy efficiency in the European Union put more demands on the distribution grids' metering systems. As a consequence of the increase in decentralised electricity production the network configuration changes drastically (from a waterfall principle to bidirectional distribution networks), but there is also an impact on the management of metering data. The above evolutions have put the introduction of smart meters in the limelight.

The Issuer has carried out several tests with smart metering in order to assess the problems and opportunities of this technology within the distribution grids it operates. A small-scale local proof of concept in Mechelen with approx. 4,000 meters was followed up by a larger pilot project in different areas involving the installation and operation of approx. 40,000 meters (of which 25,000 for electricity and 15,000 for gas).

Also the energy regulator VREG has been investigating the economic and technical aspects of the deployment of smart meters with all network users. Obviously, such a large-scale introduction requires a thorough cost/benefit analysis and a clear view on the technical capabilities of these meters.

However, it is clear at this stage that the real time data that smart meters can provide, create a number of opportunities aimed at directing networks and at the evolution towards 'smart users' and 'smart, decentralised producers'. In relation to electricity the Energy Efficiency Directive<sup>62</sup> stipulates that Member States should have installed by the year 2020 smart meters with 80 per cent of end consumers for whom an extensive cost-benefit analysis has demonstrated clear benefits for the instalment of these electronic meters. If no such cost-benefit analysis is carried out, 80 per cent of all end consumers should be connected to the distribution grid with a smart meter by the year 2020. In relation to gas the Energy Efficiency Directive requires Member States to prepare a timetable for the implementation of smart meters if the roll-out of smart meters (potentially subject to a cost-benefit analysis) is assessed positively.

Based on the knowledge and experience gained in its proof of concept test and the pilot project, Eandis System Operator has come to the conclusion that the Flemish Region should ideally opt

<sup>62</sup> Directive 2012/27/EU on energy efficiency, amending Directives 2009/125/EC and 2010/30/EU and repealing Directives 2004/8/EC and 2006/32/EC, *OJ L 315*, 14.11.2012, p. 1-56 (the "**Energy Efficiency Directive**").

for a gradual build-up for smart metering, giving priority to a few well-chosen target groups for which a smart meter can bring added value.

On 3 February 2017, the Flemish Government announced its decision on the roll-out of the digital, smart meter. Starting in 2019, the smart meter will be gradually introduced with the following target groups: (i) new buildings, (ii) buildings which have been thoroughly renovated, (iii) owners of solar panels and (iv) end consumers with a budget meter. A detailed cost/benefit analysis will be updated by the network operators. Both Eandis System Operator and Infrax have welcomed this decision of the Flemish Government as the starting point for the introduction of smart metering, which is a crucial and necessary step towards a full-fledged energy transition. Fluvius will be the instrument for the coordinated and efficient implementation of the smart meter roll-out.

#### 6.6 ***Energy Efficiency, Rational Use of Energy, Demand Side Management***

The elements in the section title fall squarely within Eandis System Operator's strategic focus on being an expert centre on energy efficiency and the climate objectives.

Today, Eandis System Operator already possesses competencies and instruments in the field of DSM. Eandis for example actively supports network users in applying energy saving measures. This policy will be continued in the future.

Eandis System Operator targets different types of customers, but with a special focus on its shareholders/local authorities. Many of these public entities have signed the Covenant of Mayors. Heralded as the "world's biggest urban climate and energy initiative" the Covenant of Mayors for Climate & Energy brings together thousands of local and regional authorities voluntarily committed to implementing EU climate and energy objectives on their territory. Signatories pledge to reduce CO<sub>2</sub> emissions by at least 40% by the year 2030 and to adopt an integrated approach to tackling mitigation and adaptation to climate change.

In its relationship with the local authorities Eandis System Operator has chosen to deliver a mix of information, advice, support, financing and suggestions as to a number of concrete energy saving measures. The objective is to have the local authorities embody best practices in the field of energy efficiency and the rational use of energy. Eandis System Operator's offer of "*Energy Services for Local Authorities*"-projects should be the instrument to bring about projects with an immediate impact on energy saving and a medium-term impact on climate objectives. Up to now, a large number of local authorities within the Issuer's operating territory has positively reacted to this offer.

#### 6.7 ***Focus on energy balancing***

A number of trends already described above, especially the rise of decentralised electricity generation, will impact the Issuer's and the Guarantors' business in the long term. In electricity distribution, the need for a well-executed balance between generation and demand will become ever more crucial and this balance should work in both directions between generation and demand. Eandis System Operator believes that three types of balancing are in play: (i) individual balancing per individual customer, in which the end user balances his consumption with his own production and *vice versa*; this implies that a minimum amount of energy is injected into the distribution grid, (ii) local balancing for a group of end users in the same neighbourhood or district; this implies the need for a locally managed (distribution) grid and, finally (iii) central balancing at the level of the entire grid, irrespective of geographical location, for which a central management system is needed; smart metering and smart grids will play a crucial role here.

The Issuer is currently working on a so-called 'route planning energy balancing', which must enable it to anticipate all future evolutions and to take the necessary implementation measures when needed.

#### 6.8 ***Implementation of (Social) Public Service Obligations***

As to its public service obligations, Eandis System Operator aims at maximizing efficiency while keeping the solidarity principle intact. The interests of the socially disadvantaged will remain a point of specific focus for Eandis System Operator. Over the years, the Issuer has gained positive

experiences with the budget meter for electricity and gas. The battle against energy poverty is one of the strategic value propositions for Eandis System Operator.

Apart from the social dimension of its public service obligations, Eandis System Operator will undoubtedly also be confronted with a number of technical public service obligations. To name but two recent examples: the compulsory installation of charging infrastructure for electric vehicles and the operational activities for public lighting. It might be expected that in the years to come, additional public service obligations will be imposed on the Guarantors/DSOs and their operating company Eandis System Operator.

#### 6.9 *Gas Network Operations*

In the foreseeable future, the gas market may be faced with the compulsory switch from low to high calorific gas, following a decision by the Dutch authorities and the Dutch gas supplier(s) to stop deliveries of low calorific gas to the Belgian market. If (and when) such a step is taken, this will involve major investments to technically adapt part of the Flemish gas distribution networks. Eandis System Operator will work on this topic in consultation and collaboration with the other Belgian distribution grid operators involved.

#### 6.10 *Renewable Energy Certificates*

##### *Overview*

In the Flemish Region a system of so-called Renewable Energy Certificates ("**RECs**") has been introduced. RECs consist of both Green Energy Certificates ("**GECs**") and Combined Heat and Power Certificates or Cogeneration Certificates ("**CHPCs**").

The three main pillars of the Flemish REC system are (i) the possibility of producers of green energy to be granted RECs, (ii) the obligation for suppliers of electricity to acquire a number of RECs each year which they need to submit to the VREG to avoid a fine (see below "*Main Principles*") and (iii) the guarantee system whereby a minimum price for the certificates is guaranteed to the producers of electricity for a predetermined period.

##### *Main principles*

Since 2002 a REC system has been in effect in the Flemish Region, with which Flanders aims to support and promote power generation based on renewable energy sources. The legal basis for this Flemish certificates' system is fixed in the Energy Decree and the implementing rules were transposed in the Energy Order. This is in essence a two-tier system. On the one hand producers of electricity based on renewable energy sources can receive RECs. On the other hand there is a certificate obligation in place for power suppliers. They must submit a specific number of RECs (quota obligation) in order to avoid a fine. The DSOs also have an important role in the guarantee system since this guarantee system has been implemented through the obligation for the DSOs to purchase RECs from certain producers of green electricity at a fixed price. The DSOs need to keep the RECs on their balance sheet (and, hence, prefinance these, until they are sold by them).

Producers of electricity based on renewable energy sources can obtain RECs from the VREG for electricity generated in the Flemish Region from the following renewable energy sources:

- Solar power
- Wind power
- Biomass energy
- Hydropower
- Wave power
- Tidal power
- Geothermal power

- Biogas
- Landfill gas
- Sewage gas

A REC corresponds to the production of a certain amount of electricity from a renewable energy source. Producers who are awarded a REC do not receive it on paper, but as an electronic item in the VREG-operated certificate database which can be consulted by producers on the Internet. Producers owning an installation with a commissioning date before 2013 can obtain RECs for every 1,000kWh net electricity produced from renewable resources. For producers owning an installation commissioned since 2013, the same number of certificates is additionally multiplied by a technology and capacity specific banding factor reflecting the amount of support needed in order to pay back the investment in a reasonable production period (see "*Banding*" below for more details).

Producers may sell these RECs. End-buyers of certificates are electricity suppliers who have to meet certificates quota (see below) and who buy their certificates directly from producers, from traders who act as intermediaries in the market or from DSOs. If the producer is also an electricity supplier, he can use his own certificates to meet his certificate obligation. Producers can obtain RECs by applying for them at the Flemish Energy Agency (*Vlaams Energieagentschap*), which judges the application and calculates the amount of certificates to be issued, and passes on this information to VREG for the issuing of RECs.

Each electricity supplier in the Flemish Region is obliged to support a specific amount of electricity generated from renewable energy sources. This amount corresponds to a specific minimum share ("quota") of total electricity they supply to their customers.

As a proof of compliance with the quota obligation, electricity suppliers are to annually submit a specific number of RECs to the VREG before 31 March of the following year. Annually, the VREG calculates the number of RECs to be submitted by each supplier in order to comply with this certificate obligation. The VREG will inform the supplier of this number, after which the supplier is to submit the required number of RECs to the VREG.

A supplier complies with its certificate obligation by submitting the correct number of RECs. Submitting too few certificates results in an administrative fine of EUR 100 per missing certificate.

Not all RECs can be used to meet the certificate obligation. Only RECs issued by the VREG are accepted. RECs awarded for the generation of electricity based on specific waste materials (waste materials that can be recycled or processed in a superior manner), are not accepted for the certificate obligation. Furthermore, RECs issued outside the Flemish Region may not be submitted to satisfy the Flemish certificate obligation. This was recently confirmed in the Essent litigation, as further outlined in "*Compatibility of the Flemish REC system with EU law*" below.

#### *Impact on the Guarantors*

##### *Included in the tariffs as public service obligation*

The Flemish REC system provides that the DSOs have an obligation to buy RECs at a predetermined price from a party requesting so. Subsequently, the DSOs must offload these RECs in the market while booking the difference between the guaranteed price and the market price for the certificates as a public service obligation cost, to be charged through in the distribution grid fee. Since substantial investments in solar energy have been made this guaranteed price system contributes materially to the rising level of the electricity distribution tariffs, the Issuer expects this contribution to remain material towards the future (albeit certain recent legislative changes may halt a further increase, as further described below in "*Reform of REC mechanism*").

## *Unsold Renewable Energy Certificates*

In addition, the Guarantors accrued around EUR 546.1 million of receivables with respect to RECs (situation as per 31 December 2016). These receivables result mainly from the inability of the Guarantors to sell all off their certificates to the market due to insufficient demand.

### *Reform of the REC mechanism*

#### *General*

As mentioned above, in the Flemish Region supply and demand in the market for RECs became deranged due to the unforeseen success of mainly solar panels. The Flemish government has tried to mitigate these effects in several ways.

#### *Banding*

A fundamental change was brought by the Flemish Decree of 13 July 2012. This Decree has altered the framework significantly by making the allocation of RECs dependent on the type of renewable technology. The purpose of this drastic reform was to tackle the historical over-subsidisation of certain technologies and the resulting significant decrease in the prices of RECs raising concerns for developers and lenders of renewable energy projects. In addition, it was clear that the costs, especially the charges included in the distribution tariffs, are higher than necessary, and unfairly distributed throughout society. The reform brought by the Decree of 13 July 2012 should have several positive implications for the Guarantors as the intended changes reduces the costs for the DSOs and the impact of the inclusion of these costs in the distribution tariffs.

First, the price of the RECs is since 2013 controlled on the basis of a banding system. This means that the level of support is fixed per type of technology that is used for the production of green energy. This fine-tuned banding mechanism should reduce the oversupply of certificates and alleviate the pressure on the DSOs. Hence, by introducing an adequate banding mechanism the producers of green electricity should in principle no longer seek the minimum support of the DSOs limiting the rising level of the distribution tariffs. The banking system entered into force on 1 January 2013. However, for photovoltaic projects (i.e. installations generating electricity with solar panels, or photovoltaic projects), the system applies retroactively as from 1 January 2012. RECs in respect of photovoltaic projects with a start date between 1 January 2012 and 1 January 2013 and for which the benefit of the minimum purchase has been granted by the DSO, should have been submitted by the DSOs to the VREG which in exchange issued a number of new certificates reduced by application of the banding factor.

Furthermore, the amount of the guaranteed minimum purchase price by the DSOs was maintained at its previous levels, except that for PV installations below 250 kW which were put into first use over the respective quarters of 2012, the minimum amount reduces more rapidly than before (as from 1 August 2012, the support was already reduced to EUR 90). It should be mentioned as well that to reduce the burden of the RECs scheme on large industrial clients, supplies to such industrial clients benefit from increased exemptions from the quota obligation provided they sign an energy efficiency covenant that is approved by the Flemish Government. In addition, RECs, once issued, now have a validity period of 10 years (instead of the previous 5 years). This gives the generation projects more flexibility in time to monetise their certificates and gives the DSOs who have purchased such certificates also more time to sell the certificates again in the market.

#### *Banking*

Besides the effect of the new banding mechanism, the DSOs also have the obligation to temporarily immobilise (bank) RECs in order to moderate the market price of these certificates. In 2014 the Flemish Government introduced such a banking regime obliging the DSOs to bank a number of certificates they purchased during a period of oversupply of certificates to allow the inefficient certificates market to balance itself again. Pursuant to this scheme the DSOs had to bank 1.5 million GECs and 1 million CHPCs until 1 July 2016. For the Guarantors this amounts to approximately 1 million GECs and half a million CHPCs. This banking regime might be

extended (but the banking period may never exceed 10 years). If at a certain stage a shortage of certificates would occur, the DSOs will have to release a number of certificates.

The DSOs may sell the banked certificates, either at the end of the banking period, or earlier in case of release for resp. EUR 93 for RECs and EUR 27 for CHPCs. In case the sale price is lower than the fixed minimum price, the DSOs may book the difference between the sale price and the minimum price as a financial public service obligation.

The DSOs are compensated for their banking activities. The compensation for this banking responsibility is capped at EUR 2.8 million per year in total for all DSOs. In addition, the total financial remuneration (i.e. the negative difference in price following the sale of the banked RECs + the said remuneration for the banking tasks itself) payable to an individual DSO per year may never exceed EUR 15 million.

Finally, the Flemish Region and the DSOs might conclude an energy policy agreement (*energiebeleidsovereenkomst*) which could further develop the banking regime and would exist in parallel with the existing regime.

#### *Remedies by the Flemish Government to alleviate the excess inventory*

The Flemish Government also introduced an additional levy in 2016 on electricity consumption (the "**Flemish Energy Contribution**") which contributes to a specific fund dedicated to remove the excess REC inventory. Until then this Flemish Energy Contribution amounted to EUR 3 per annum but a decree approved by the Flemish Parliament on 7 December 2015 increased this amount. The increased levy was applied as from 1 March 2016. Households in the Flemish Region with an off-take point which is not subject to VAT pay an additional levy per year for electricity. Disadvantaged customers that have a budget meter installed in their homes have to pay a levy of EUR 25 per annum, whilst energy users using less than 5MWh per year pay EUR 100 per annum. Consumers using between 5MWh and 10MWh will pay EUR 130 per annum and, since 1 January 2017, consumers using between 20MWh and 25MWh pay EUR 290 per annum.

#### *The DAEB mechanism*

Out of the fund financed by the contributions raised by the Flemish Energy Contribution (see above), the Flemish Energy Agency was able to purchase additional certificates (RECs) for an amount of EUR 15 million per individual DSO/Guarantor in December 2016. This step resulted in a decrease of the total receivables of the Guarantors of approximately EUR 105 million.

#### *The impact of the RECs on the Regulatory Assets*

The VREG acknowledges that the unforeseen success of mainly solar panels and the corresponding green power support regime has burdened the balance sheet of the Flemish DSOs. This not only happened due to the build-up of RECs on the balance sheet (which will be processed via the new fund mechanism as recently proposed by the Flemish Government), but also in the form of the existing large amount of RALs (for more details see section 3.7 in "*Part VIII - Regulatory Framework applicable to the Flemish DSOs*" above). A large portion of these existing RALs were created due to the prolongation of the 2009-2012 regulatory period to 2013 and 2014. Given the non-adjustment of the non-manageable costs (which were much higher than initially estimated), these did not fully compensate the DSOs for the unexpected large amount of RECs, resulting in the creation of Regulatory Assets. These Regulatory Assets will be included in the tariffs over the coming years.

#### *Restrictions for certain solar panels*

Finally, new solar panels with a capacity of  $\leq 10$  kW and which have been certified on 14 June 2015 or later will no longer receive RECs.

#### *Compatibility of the Flemish REC scheme with EU law*

In 2012 Essent, an electricity supplier, contested the Flemish REC scheme. In order to discharge its quota obligation Essent, surrendered to the Flemish authorities guarantees of origin



confirming the production of green electricity in Denmark (and/or in Sweden), the Netherlands and Norway. The VREG refused to accept those guarantees as RECs on the ground that they could be issued only for electricity produced in Flanders. Essent was fined for approximately EUR 1.5 million. In turn Essent brought a number of actions before the Brussels Court of First Instance taking the view that the decisions of the VREG infringe the Renewable Energy Directive and the principle of the free movement of goods. The Brussels Court of First Instance subsequently raised a prejudicial question to the European Court of Justice.

On 11 September 2014 the Court of Justice ruled that the Flemish REC scheme is compatible with EU law.

In essence, the Court observed that the Flemish scheme of RECs is capable of hindering imports of electricity, especially green electricity, from other Member States. However, the Court found that that restriction is justified by the public interest objective consisting in promoting the use of renewable energy sources with a view to protecting the environment and combating climate change. The Court acknowledged that the Flemish Region was justified in considering that, for those purposes, it was appropriate to reserve the REC scheme exclusively to green electricity produced in the regional territory.

The Court pointed out, however, that the restriction arising from that support scheme is only justified to the extent it is actually possible for electricity importers to obtain RECs under fair terms in a genuine market for certificates. Similarly, no excessive penalties must be imposed on traders that have not fulfilled their REC quota obligation. In those circumstances, the Court held that the Flemish scheme of RECs is, in principle, compatible with the principle of the free movement of goods.

## 7. Investments

The annual investment budgets of the Eandis Economic Group for the period 2017-2020 are as follows (all figures in the table are net investments, i.e. after deduction of the financial contribution by the end users):

	<u>2017</u>	<u>2018</u>	<u>2019</u>	<u>2020</u>
	<i>(million EUR)</i>			
Electricity .....	307,7	288,2	282,4	287,7
Gas.....	138,8	128,0	126,6	123,0
<b>TOTAL.....</b>	<b><u>446,5</u></b>	<b><u>416,2</u></b>	<b><u>409,0</u></b>	<b><u>410,7</u></b>

The investments of the Eandis Economic Group are carried out in accordance with an investment programme approved by the VREG.

The investment programmes are not funded upfront. According to the expectations of the Issuer, based on its most recent forecasts in respect of the investment budgets and their application, the investments of the Guarantors (for the avoidance of doubt, excluding the refinancing of existing indebtedness) will be financed, primarily out of the financial means generated by the Guarantors, and to a limited extent, to the extent such auto-financing is not sufficient, through additional instruments of external indebtedness (in respect of which indebtedness please see section 2.6 of "*Part X – Selected Financial Information*").

The diagrams below provide an overview of the type of investments carried out by the Eandis Economic Group in the financial year 2016, and their relative importance. The categories of investments and their relative importance remained stable since 31 December 2016 until the date of this Prospectus, and the expectation is that, for the period until 2020 and absent unforeseen circumstances, the relative proportion of the various types of investments will remain relatively stable.

Electricity (gross investment of EUR 321.2 million):

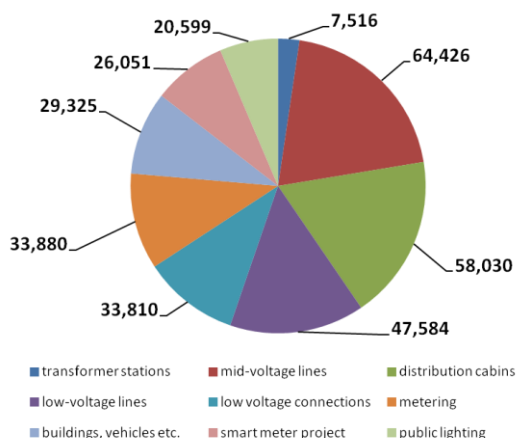

Gas (gross investment of EUR 148.2 million):

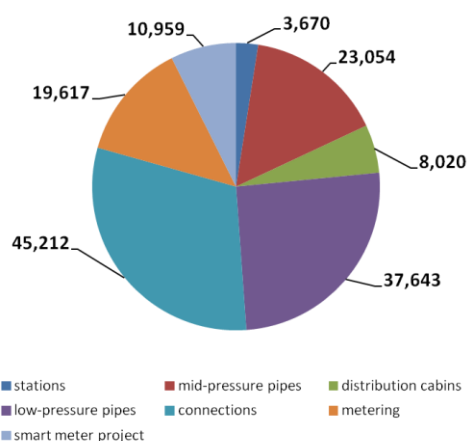

## 8. Possible complete integration with Infrac

Eandis System Operator and Infrac (Infrac being the operating company of the distribution system operators for electricity and natural gas in those parts of Flanders not covered by the Guarantors) established in December 2016 a joint affiliate company "Fluvius"; in doing so, both companies agreed to strengthen their cooperation in addressing future challenges for distribution system operators, and to work together on new projects that may be developed.

In discussions held since then at the level of both operating companies' management and in the respective boards of directors, opportunities for more efficient grid management, including one-off and recurrent financial synergies which can be realised through a more integrated cooperation between Eandis System Operator and Infrac, have been identified.

Following the approval by the board of directors of Eandis System Operator, Infrac, Fluvius and all of their respective shareholders, Eandis System Operator and Infrac announced on 11 May 2017 the start of a process that would eventually lead to a complete integration of Eandis System Operator and Infrac under the name "Fluvius". The latter is to become the new multi-utility operator for the entire Flemish Region.

The respective management teams of Eandis System Operator and Infrac have been given the mandate by their boards of directors to prepare a roadmap for such complete integration, and continue the discussions with the relevant stakeholders, including their respective shareholders, the municipal shareholders of the distribution system operators, the competent regulators and the Flemish Region.

Both the timing of the complete integration and the actual form such cooperation will take have not been decided yet, among others because both aspects are likely to be influenced by the ongoing discussions with the relevant stakeholders, including the legal leeway that needs to be provided to allow for a change to the articles of association of the Issuer and Infrac prior to 2019, which requires changes to the legal regime to be made by the Flemish Region. It is, however, the current expectation that decisions around the structure of such complete integration will not be taken before the autumn of 2017. The stated aim is for the integration process to be finalised by 2020 at the latest. The Issuer will of course respect the rights of its bondholders during such process with a view to ensure such process takes place in accordance with the terms of its indebtedness (or with the consent of its creditors to the extent required). It is the expectation of the Issuer that any such transaction will be permitted under the Terms and Conditions of the Bonds, and hence not give rise to an Event of Default.

In the meantime, Eandis System Operator and Infrac will strive to continue to strengthen their cooperation in the field. This includes the intention to have, as from January 2018, joint management committee sessions involving the members of the management committees of each of Eandis System Operator and Infrac, with the aim to bring together from both companies as much expertise as possible and to carry out the whole integration process in the smoothest possible way, without any impact on customers, investors and other stakeholders.

As managing director Mr Walter Van den Bossche will define the mission, vision, strategy and policy guidelines for Fluvius and he will be responsible for the day-to-day management. He will be assisted by Mr Frank Vanbrabant, who as CEO will lead the executive management and implement the chosen strategy. This situation will continue until May 2019. Then Frank Vanbrabant as CEO will become the sole lead.

During, and following, the establishment of the complete integration, the activities of both operating companies in respect of electricity, natural gas, sewerage, district heating, cable and public lighting will not be impacted, and the expectation remains that, ultimately, the integrated multi-utility operating company will continue to carry out these activities in the relevant regions in Flanders. Further, the Guarantors are – other than in their capacity as shareholders of the Issuer – not directly involved in the proposed complete integration, which will not affect their financial position, nor the guarantee(s) granted by any of them (including the Guarantees granted by them to the Bondholders).

9. **Membership of professional organisations**

The Guarantors and Eandis System Operator are members of Synergrid vzw, which is the federation of electricity and gas grid operators in Belgium.

The Issuer is also a member of the European Distribution System Operators for Smart Grids (EDSO for Smart Grids).

10. **Statutory Auditors Charged with the statutory audit**

The Issuer's statutory auditor is Ernst & Young Bedrijfsrevisoren BCVBA (EY), represented by Mr Paul Eelen, Moutstraat 54, 9000 Ghent (Belgium)

The statutory auditors of the Guarantors are:

<b>Guarantor</b>	<b>Public accountant and address</b>
<b>GASELWEST</b>	<b>Ernst &amp; Young Bedrijfsrevisoren BCVBA,</b> represented by Mr Paul Eelen Moutstraat 54, 9000 Ghent (Belgium)
<b>IMEA</b>	<b>Ernst &amp; Young Bedrijfsrevisoren BCVBA,</b> represented by Mr Paul Eelen

	Moutstraat 54, 9000 Ghent (Belgium)
<b>IMEWO</b>	<b>Ernst &amp; Young Bedrijfsrevisoren BCVBA,</b> represented by Mr Paul Eelen Moutstraat 54, 9000 Ghent (Belgium)
<b>INTERGEM</b>	<b>Ernst &amp; Young Bedrijfsrevisoren BCVBA,</b> represented by Mr Paul Eelen Moutstraat 54, 9000 Ghent (Belgium)
<b>IVEKA</b>	<b>Ernst &amp; Young Bedrijfsrevisoren BCVBA,</b> represented by Mr Paul Eelen Moutstraat 54, 9000 Ghent (Belgium)
<b>IVERLEK</b>	<b>Ernst &amp; Young Bedrijfsrevisoren BCVBA,</b> represented by Mr Paul Eelen Moutstraat 54, 9000 Ghent (Belgium)
<b>SIBELGAS</b>	<b>Klynveld Peat Marwick Goerdeler KPMG Bedrijfsrevisoren B.C.V.B.A.,</b> represented by Mr E. Clinck Prins Boudewijnlaan 24d, 2550 Kontich (Belgium)

The statutory auditor for De Stroomlijn, consolidated Subsidiary of Eandis System Operator, is:

<p><b>Figurad Bedrijfsrevisoren, represented by Mr Stefaan Beirens, auditor</b></p> <p><i>burgerlijke vennootschap onder de vorm van een besloten vennootschap met beperkte aansprakelijkheid</i></p> <p>Jean-Baptiste de Ghellincklaan 21, 9051 Sint-Denijs-Westrem (Ghent, Belgium)</p>
---

The statutory auditor for Atrias, consolidated Subsidiary of Eandis System Operator, is:

<p><b>Alain SERCKX sprl, represented by Mr Alain Serckx, auditor</b></p> <p>Rue Ernest Salu 91</p> <p>1020 Laken - Brussels (Belgium)</p>
---

The statutory auditor for Synductis, subsidiary of Eandis System Operator, is:

<p><b>Figurad Bedrijfsrevisoren, represented by Mr Stefaan Beirens, auditor</b></p> <p><i>burgerlijke vennootschap onder de vorm van een besloten vennootschap met beperkte aansprakelijkheid</i></p> <p>Jean-Baptiste de Ghellincklaan 21, 9051 Sint-Denijs-Westrem (Ghent, Belgium)</p>
---

The statutory auditor for Warmte@Vlaanderen, subsidiary of Eandis System Operator, is:

**Ernst & Young Bedrijfsrevisoren BCVBA, represented by Mr Stefan Olivier, auditor**

*burgerlijke vennootschap onder de vorm van een besloten vennootschap met beperkte aansprakelijkheid*

De Kleetlaan 2, 1831 Diegem (Belgium)

The statutory auditor for Fluvius, subsidiary of Eandis System Operator, is:

**Ernst & Young Bedrijfsrevisoren BCVBA, represented by Mr Stefan Olivier, auditor**

*burgerlijke vennootschap onder de vorm van een besloten vennootschap met beperkte aansprakelijkheid*

De Kleetlaan 2, 1831 Diegem (Belgium)

Each of the statutory auditors of the Issuer, the Guarantors and Eandis System Operator's subsidiaries is a member of the Belgian "*Instituut van de Bedrijfsrevisoren/Institut des Réviseurs d'Entreprises*".

## PART X – SELECTED FINANCIAL INFORMATION

### 1. Selected historical financial information of the Issuer as of and for the financial years ended 31 December 2016 and 31 December 2015

The following tables set out in summary form certain balance sheet, income statement and cash flow information relating to the Issuer. The information has been extracted from the audited consolidated statements of the Issuer as of and for the years ended 31 December 2016 and 31 December 2015. These consolidated statements of the Issuer have been prepared in accordance with IFRS. The audited, consolidated financial statements of the Issuer as of and for the year ended 31 December 2016 have been established by the Board of Directors on 29 March 2017 and approved by the Issuer's Annual General Meeting of Shareholders on 19 May 2017. The auditor of the Issuer has issued an unqualified opinion on the consolidated statements of the Issuer as of and for the years ended 31 December 2016 and 31 December 2015.

The scope of consolidation is the Issuer as consolidating entity and Atrias, De Stroomlijn, Indexis (only for the period until 31 December 2015) and Synductis as consolidated entities. Warmte@Vlaanderen and Fluvius have not been included in the consolidation.

#### 1.1 Consolidated Income Statement of profit or loss for the year ended 31 December 2016 and 31 December 2015

	For the year ended 31 December 2016	For the year ended 31 December 2015	Change between 2016-2015 (%)
<i>(In thousands of EUR)</i>			
<b>Operating revenue</b> .....	<b>998,121</b>	<b>1,044,062</b>	<b>-4,4</b>
Revenue .....	975,843	1,026,543	-4,9
Other operating revenue .....	22,278	17,519	+27,2
Own construction capitalized .....	0	0	
<b>Operating expenses</b> .....	<b>-978,829</b>	<b>-1,023,479</b>	<b>-4,4</b>
Changes in inventories of finished goods and raw materials.....	-88,851	-79,785	+11,4
Cost for services and other consumables.....	-522,885	-570,927	-8,4
Employee benefit expenses .....	-360,963	-368,432	-2,0
Depreciation, amortisation and changes in provisions.....	-5,473	-3,926	+39,4
Other operational expenses .....	-657	-409	+60,6
<b>Result from operations</b> .....	<b>19,292</b>	<b>20,583</b>	<b>-6,3</b>
Finance income .....	109,107	109,431	-0,3
Finance costs .....	-119,206	-119,552	-0,3
<b>Profit (loss) before tax</b> .....	<b>9,193</b>	<b>10,462</b>	<b>-12,1</b>
<b>Income tax expenses</b> .....	<b>-9,193</b>	<b>-10,462</b>	<b>+12,1</b>
<b>Result for the period</b> .....	<b>0</b>	<b>0</b>	<b>-4,4</b>

#### 1.2 Consolidated Statement of comprehensive income for the year ended 31 December 2016 and 31 December 2015

	For the year ended 31 December 2016	For the year ended 31 December 2015
<i>(In thousands of EUR)</i>		
Result for the period .....	0	0
Actuarial gain (loss) on long term employee benefits .....	5,311	51,003
Actuarial gain (loss) on rights to reimbursement on long term employee benefits .....	-5,311	-51,003
Other comprehensive income .....	0	0
<b>Total comprehensive income for the period</b> .....	<b>0</b>	<b>0</b>

1.3 *Consolidated Statement of Financial Position as at 31 December 2016 and 31 December 2015*

	31 December 2016	31 December 2015
	<i>(In thousands of EUR)</i>	
<b>Non-current assets</b> .....	<b>3,534,199</b>	<b>3,756,646</b>
Intangible assets.....	780	1,204
Property, plant and equipment.....	2,303	2,512
Investments in other companies.....	30	11
Other investments, other.....	832	919
Rights to reimbursement on post-employment employee benefits.....	259,363	331,250
Long term receivables, other.....	3,270,891	3,420,750
<b>Current assets</b> .....	<b>818,190</b>	<b>449,949</b>
Short-term receivables – other.....	35,295	
Inventories.....	150,000	45,316
Trade and other receivables.....	322,646	255,506
Receivables cash pool activities.....	307,587	145,492
Cash and cash equivalents.....	2,662	3,635
<b>TOTAL ASSETS</b> .....	<b>4,352,389</b>	<b>4,206,595</b>
<b>EQUITY</b> .....	<b>1,099</b>	<b>1,099</b>
<b>Equity attributable to owners of the parent</b> .....	<b>1,006</b>	<b>20</b>
Share capital and reserves.....	1,006	20
<b>Non-controlling interest</b> .....	<b>93</b>	<b>1,079</b>
<b>LIABILITIES</b> .....	<b>4,351,290</b>	<b>4,205,496</b>
<b>Non-current liabilities</b> .....	<b>3,506,515</b>	<b>3,726,010</b>
Interest bearing loans and borrowings.....	3,247,152	3,394,760
Employee benefit liability.....	259,363	331,250
<b>Current liabilities</b> .....	<b>844,775</b>	<b>479,486</b>
Interest bearing loans and borrowings.....	561,321	225,238
Trade payables and other current liabilities.....	269,868	236,859
Liabilities cash pool activities.....	0	11,400
Current tax liabilities.....	13,586	5,989
<b>TOTAL EQUITY AND LIABILITIES</b> .....	<b>4,352,389</b>	<b>4,206,595</b>

1.4 *Consolidated Cash-flow Statement for the year ended 31 December 2016 and 31 December 2015*

	For the year ended 31 December 2016	For the year ended 31 December 2015
	<i>(In thousands of EUR)</i>	
<b>Result for the period</b> .....	<b>0</b>	<b>0</b>
Amortization of intangible assets.....	428	478
Depreciation on property, plant and equipment.....	920	1,169
Impairment on current assets (reversal-; recognition +).....	4,125	2,279
Gain or loss on realization receivables.....	106	163
Net finance expense.....	10,099	10,121
Gain or loss on sale of property, plant and equipment.....	23	0
Income tax expense (income).....	9,193	10,462
<b>Operating cash flow before changes in working capital and provisions for employee benefits</b> .....	<b>24,894</b>	<b>24,672</b>
Change in inventories.....	10,022	-11,117
Change in trade and other receivables.....	-71,289	708,933
Change in trade payables and other current liabilities.....	32,999	35,490
<b>Net operating cash flow</b> .....	<b>-28,268</b>	<b>733,306</b>
Interest paid.....	-116,792	-117,743
Interest received.....	108,652	109,149
Financial discount on debts.....	291	460

	For the year ended 31 December 2016	For the year ended 31 December 2015
	<i>(In thousands of EUR)</i>	
Income tax paid.....	-1,596	-7,381
<b>Net cash flow from/used in operating activities .....</b>	<b>-12,819</b>	<b>742,463</b>
Proceeds from sale of property, plant and equipment.....	10	0
Purchase of intangible assets.....	-4	-333
Purchase of property, plant and equipment.....	-744	-208
Purchase of financial assets.....	-19	0
Proceeds from sale of other investments .....	168	387
Net investment in other long term receivables .....	-141	9
<b>Net cash flow used in investing activities .....</b>	<b>-730</b>	<b>-145</b>
Proceeds from short term loans and borrowings .....	186,074	225,238
Change in cash pool .....	-173,495	-972,827
Net cash flow from/used in financing activities .....	12,576	-747,589
<b>Net change in cash and cash equivalents .....</b>	<b>-973</b>	<b>-5,271</b>
Cash and cash equivalents - at beginning of period.....	3,635	8,906
<b>Cash and cash equivalents - at end of period.....</b>	<b>2,662</b>	<b>3,635</b>

#### 1.5 *Audit of historical financial information for the Issuer*

The independent auditor of the Issuer is Ernst & Young Bedrijfsrevisoren BCVBA (abbreviated EY), represented by Mr. Paul Eelen.

#### 2. **Selected consolidated historical financial information of Eandis Economic Group as of and for the financial years ended 31 December 2016 and 31 December 2015**

The following tables set out in summary form certain balance sheet, income statement and cash flow information relating to the Eandis Economic Group. The information has been extracted from the audited consolidated financial statements of the Eandis Economic Group as of and for the years ended 31 December 2016 and 31 December 2015. These consolidated financial statements of the Eandis Economic Group have been prepared in accordance with IFRS. The auditor has issued an unqualified opinion on the consolidated financial statements as of and for the years ended 31 December 2016 and 31 December 2015. However, an emphasis of matter paragraph was added to these Audit Reports relating to the tariff regime (please see *Part VIII – Regulatory framework applicable to the Flemish DSOs* " and more in particular section 3.7 thereof).

The audited consolidated financial statements of the Eandis Economic Group as of and for the years ended 31 December 2016 and 31 December 2015 (including the audit report), and the balance sheet and income statement of each of the Guarantors as of and for the years ended 31 December 2016 and 31 December 2015, are included as Annexes 2 to 4 to the Prospectus.

#### 2.1 *Eandis Economic Group Consolidated Statement of Profit or Loss for the year ended 31 December 2016 and 31 December 2015*

	For the year ended 31 December 2016	For the year ended 31 December 2015	Change between 2016-2015 (%)
	<i>(In thousands of EUR)</i>		
<b>Operating revenue.....</b>	<b>2,788,767</b>	<b>2,677,762</b>	<b>+4.1</b>
Revenue .....	2,454,266	2,315,718	+6.0
Other operating income .....	65,576	59,116	+10.9
Own construction, capitalized .....	268,925	302,928	-11.2
<b>Operating expenses .....</b>	<b>-2,169,960</b>	<b>-2,065,689</b>	<b>+5.0</b>
Cost of trade goods.....	-1,039,602	-1,025,983	+1.3
Cost for services and other consumables.....	-324,824	-488,053	-33.4



	For the year ended 31 December 2016	For the year ended 31 December 2015	Change between 2016-2015 (%)
<i>(In thousands of EUR)</i>			
Employee benefit expenses .....	-360,996	-368,472	-2.0
Depreciation, amortisation, impairments and changes in provisions .....	-325,901	-333,272	-2.2
Other operational expenses .....	-46,881	-55,888	-16.1
Regulated balances and transfers .....	-71,756	205,979	-134.8
<b>Result from operations .....</b>	<b>618,807</b>	<b>612,073</b>	<b>+1.1</b>
Finance income .....	15,913	27,011	-41.1
Finance costs .....	-205,922	-211,874	-2.8
<b>Profit before tax .....</b>	<b>428,798</b>	<b>427,210</b>	<b>+0.4</b>
Income tax expenses .....	-145,906	-142,767	+2.2
<b>Profit for the period .....</b>	<b>282,892</b>	<b>284,443</b>	<b>-0.5</b>

2.2 *Eandis Economic Group Consolidated Statement of Comprehensive income for the year ended 31 December 2016 and 31 December 2015*

	For the year ended 31 December 2016	For the year ended 31 December 2015	Change between 2016-2015 (%)
<i>(In thousands of EUR)</i>			
Profit for the period .....	282,892	284,443	-0.5
Actuarial gain (loss) on long term employee benefits .....	-5,311	51,003	-110.4
Deferred taxes .....	15,564	-2,929	-631.4
<b>Net other comprehensive income not being reclassified to profit or loss in subsequent periods .....</b>	<b>10,253</b>	<b>48,074</b>	<b>-78.7</b>
<b>Total comprehensive income for the period .....</b>	<b>293,145</b>	<b>332,517</b>	<b>-11.8</b>

2.3 *Eandis Economic Group Consolidated Statement of Financial Position as at 31 December 2016 and 2015*

	As at 31 December 2016	As at 31 December 2015
<i>(In thousands of EUR)</i>		
<b>Non-current assets .....</b>	<b>7,902,818</b>	<b>7,908,256</b>
Intangible assets .....	96,776	105,586
Property, plant and equipment .....	7,804,089	7,800,585
Investments in an associate .....	30	11
Other investments .....	832	919
Long term receivables .....	1,091	1,155
<b>Current assets .....</b>	<b>1,715,003</b>	<b>1,814,932</b>
Inventories .....	35,295	45,316
Trade and other receivables .....	1,677,000	1,765,960
Cash and cash equivalents .....	2,708	3,656
<b>TOTAL ASSETS .....</b>	<b>9,617,821</b>	<b>9,723,188</b>
<b>EQUITY .....</b>	<b>2,063,972</b>	<b>1,977,198</b>
<b>Total equity attributable to owners of the parent .....</b>	<b>2,063,879</b>	<b>1,976,119</b>
Capital .....	1,262,948	1,278,688
Reserves .....	811,641	759,548
Other components of equity .....	-641,178	-651,430
Retained earnings .....	630,468	589,313
<b>Non-controlling interest .....</b>	<b>93</b>	<b>1,079</b>
<b>LIABILITIES .....</b>	<b>7,553,849</b>	<b>7,745,990</b>
<b>Non-current liabilities .....</b>	<b>5,944,950</b>	<b>6,027,245</b>

	As at 31 December 2016	As at 31 December 2015
<i>(In thousands of EUR)</i>		
Interest bearing loans and borrowings .....	5,244,409	5,197,393
Employee benefit liability .....	259,363	331,250
Derivative financial instruments .....	131,067	145,715
Provisions .....	14,936	18,027
Deferred tax liabilities .....	343,819	334,860
Government grants .....	1,356	0
<b>Current liabilities .....</b>	<b>1,558,899</b>	<b>1,718,745</b>
Interest bearing loans and borrowings .....	766,697	963,796
Trade payables and other current liabilities .....	589,936	647,471
Current tax liabilities .....	202,266	107,478
<b>TOTAL EQUITY AND LIABILITIES .....</b>	<b>9,617,821</b>	<b>9,723,188</b>

2.4 *Eandis Economic Group Consolidated Cash-flow Statement for the year ended 31 December 2016 and 31 December 2015*

	For the year ended 31 December 2016	For the year ended 31 December 2015
<i>(In thousands of EUR)</i>		
<b>Profit for the period .....</b>	<b>282,892</b>	<b>284,443</b>
Amortisation of intangible assets .....	45,824	44,264
Depreciation on property, plant and equipment .....	282,676	292,841
Change in provisions (Reversal -; Recognition +) .....	-3,091	-2,450
Impairment current assets (Reversal -; Recognition +) .....	492	-1,383
Gains or losses on realization receivables .....	6,878	11,690
Net finance costs .....	204,657	208,989
Change in fair value of derivative financial instruments .....	-14,648	-24,125
Gains or losses on sale of property, plant and equipment .....	28,144	40,308
Movement in government grants .....	-1	0
Income tax expense .....	145,906	142,767
<b>Operating cash flow before change in working capital and provisions for employee benefits .....</b>	<b>979,729</b>	<b>997,344</b>
Change in inventories .....	10,021	-11,117
Change in trade and other receivables .....	83,143	486,697
Change in trade payables and other current liabilities .....	-54,092	80,447
Change in employee benefits .....	-77,198	-42,821
<b>Net operating cash flow .....</b>	<b>-38,126</b>	<b>513,206</b>
Interest paid .....	-206,959	-211,917
Interest received .....	711	2,306
Financial discount on debts .....	476	673
Income tax paid .....	-26,596	-19,002
<b>Net cash flow from operating activities .....</b>	<b>709,235</b>	<b>1,282,610</b>
Proceeds from sale of property, plant and equipment .....	21,240	3,091
Purchase of intangible assets .....	-37,014	-43,291
Purchase of property, plant and equipment .....	-335,565	-391,201
Acquisition of companies and other investments .....	-19	0
Proceeds from sale of other investments .....	167	387
Net investments in long term receivables .....	-135	9
<b>Net cash flow used in investing activities .....</b>	<b>-351,326</b>	<b>-431,005</b>
Proceeds from issue of shares .....	0	117,734
Repayment of share capital .....	-40,618	-895,798
Repayment of borrowings .....	-738,558	-516,126
Proceeds from borrowings .....	400,000	400,000
Change in current liabilities .....	186,071	225,238
Transfer of guarantee for allotments .....	0	-2,285

	<b>For the year ended 31 December 2016</b>	<b>For the year ended 31 December 2015</b>
	<i>(In thousands of EUR)</i>	
Dividends paid.....	-165,752	-185,625
<b>Net cash flow from/used in financing activities.....</b>	<b>-358,857</b>	<b>-856,862</b>
<b>Net decrease in cash and cash equivalents.....</b>	<b>-948</b>	<b>-5,257</b>
Cash and cash equivalents at the beginning of the period.....	3,656	8,913
Cash and cash equivalents at the end of the period.....	2,708	3,656

## 2.5 *Audit of historical financial information of the Eandis Economic Group*

The independent auditor of the Issuer is Ernst & Young Bedrijfsrevisoren BCVBA (abbreviated EY), represented by Mr. Paul Eelen. See section 8 under "*Description of the Issuer and the Guarantors*" for the auditors of the other members of the Eandis Economic Group.

## 2.6 *Financing of the Eandis Economic Group*

### *General*

The Eandis Economic Group attracts financing from various sources. The Eandis Economic Group addresses short term funding needs primarily through its commercial paper programme, as well as through various short term revolving credit facilities, both committed and non-committed. All bonds and notes financing of the Eandis Economic Group is contracted by Eandis System-Operator, with guarantees from the Guarantors, and such indebtedness is on-lent by the Issuer to the Guarantors (save where such indebtedness is used by the Issuer to refinance its indebtedness). All long term bank loans are contracted by the relevant Guarantors. No third parties have granted guarantees in respect of the indebtedness of the Eandis Economic Group. All indebtedness of the Issuer and the Guarantors is unsecured.

### *Long term financing*

The total amount of long term financial debt, including the current portion of the long term debt, of the Eandis Economic Group amounts to EUR 5,599.8 million as of 31 December 2016.

The below tables provide an overview of the composition of the long term financing of the Eandis Economic Group and its maturity profile.

<b>Overview long term financing Eandis Economic Group (in thousands EUR)</b>				<b>As at 31 December 2016</b>
<b>Bank loans</b>	<b>Bonds (EMTN)</b>	<b>Bonds (retail)</b>	<b>Private Placements (stand alone instruments)</b>	<b>Total (outstanding)</b>
2,202,633	2,642,164	319,958	435,042	<b>5,599,797</b>

The Eandis Economic Group strives to optimise the maturity profile of its debt. The amounts to be paid by the Eandis Economic Group on account of principal and interests on its long term financing are set out in the maturity profile below:

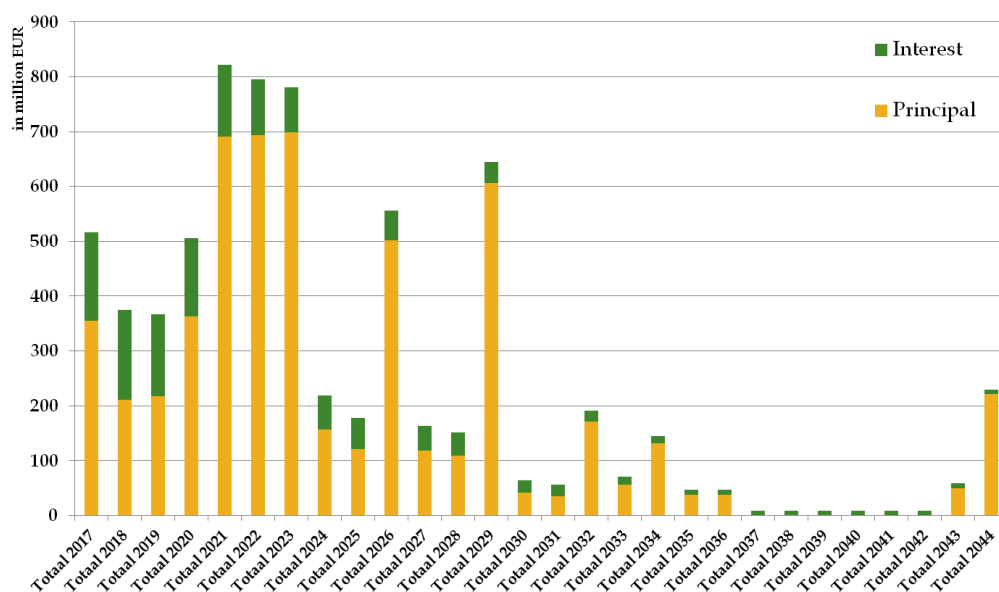

Long term financing is obtained through a broad range of different bank loans contracted with various banks through separate agreements. The Eandis Economic Group is currently not in default under any covenants set out in such agreements.

Since the Eandis Economic Group wishes to diversify its funding basis, the Eandis Economic Group funds itself in a substantial manner through the issuance of bonds, among others under its EMTN-programme. The outstanding amount of long term bank loans is EUR 2,202.6 million. Long term debt securities are issued and outstanding for an aggregate amount of EUR 3,397.2 million.

#### Short term financing

The Eandis Economic Group has the benefit of various financing arrangements to cater for its short term financing needs. The below table provides an overview hereof:

Overview short term financing Eandis Economic Group (in million EUR)			As at 31 December 2016
Instrument	Maximum amount	Amount outstanding	Committed by banks
Commercial Paper .....	522.0	355.0	No
Fixed loans/ Bank account draft facility <sup>63</sup> .....	200.0	56.3	Yes
Fixed advances .....	200.0	0.0	Yes
Fixed loans .....	100.0	0.0	Yes
<b>Total</b> .....	<b>1,022.0</b>	<b>411.3</b>	

<sup>63</sup> The overnight cash facility is non-cumulative with the bank account draft facility.

An overview of the evolution of the total amounts of debt borrowed or raised by the Eandis Economic Group and the applicable leverage over the last periods is provided in the table below:

**Evolution of financing Eandis Economic Group**

	As at 31/12/2016	As at 31/12/2015
<b>Long term borrowing</b> .....	<b>5,244,409</b>	<b>5,197,393</b>
Current portion of long term loans.....	355,388	738,558
Short term loans .....	411,309	225,238
Short term loans (including current portion of long term loans).....	766,696	963,795
<b>Total</b> .....	<b>6,011,105</b>	<b>6,161,189</b>
Leverage <sup>64</sup> .....	2.91	3.12

*Overview of indebtedness of the Issuer and the Guarantors*

The below table provides a breakdown of the indebtedness for the Issuer and each of the Guarantors, and includes the debt ratio for each of these entities as at 31 December 2015 and 2016. Such indebtedness is unsecured. Amounts are expressed in thousands.

	Total external indebtedness		Of which more than one year		Of which short term (including current portion of long term)		Debt ratio <sup>65</sup>		Total intercompany indebtedness	
	As at 31 December of									
	2015	2016	2015	2016	2015	2016	2015	2016	2015	2016
Issuer .....	3,619,998	3,808,473	3,394,760	3,247,152	225,238	561,321	86%	88%	11,400	0
Gaselwest ....	571,059	467,861	389,061	426,574	181,998	41,287	26%	22%	780,212	822,797
IMEA .....	214,729	178,793	144,593	162,207	70,136	16,586	24%	21%	273,794	288,517
Imewo .....	567,547	522,849	427,528	471,196	140,019	51,653	26%	24%	813,149	813,804
Intergem.....	293,647	251,630	199,910	227,598	93,737	24,032	29%	24%	343,075	370,429
Iveka .....	367,346	316,679	262,878	287,924	104,468	28,755	25%	21%	549,458	598,724
Iverlek.....	465,012	412,770	336,290	374,201	128,722	38,569	24%	22%	724,534	738,426
Sibelgas.....	61,850	52,052	42,372	47,557	19,478	4,495	22%	20%	81,771	95,390

*Maturity table of the Issuer and the Guarantors*

The following table sets out the amounts of the Issuer and each of the Guarantors' external long term indebtedness (*ie* excluding, for the Guarantors, any intercompany loans granted to such Guarantor by the Issuer) that mature in each year:

	2017	2018	2019	2020	2021
Issuer .....	150,000,000.00	0.00	0.00	170,000,000.00	500,000,000.00
Gaselwest.....	41,286,835.41	42,301,195.35	43,348,190.77	41,916,627.05	41,703,336.45
IMEA .....	16,585,541.05	17,058,265.23	17,544,238.32	15,223,428.68	15,387,012.00
Imewo .....	51,652,559.05	53,211,975.47	54,823,586.32	45,226,293.92	44,642,568.30
Intergem.....	24,031,751.23	24,744,105.88	25,478,079.13	21,230,489.53	20,857,045.45
Iveka .....	28,754,706.98	29,568,398.78	30,406,406.52	27,861,194.13	28,070,467.13
Iverlek.....	38,568,732.42	39,681,757.93	40,829,560.17	36,244,318.75	35,826,932.63
Sibelgas.....	4,495,609.82	4,616,448.26	4,740,436.36	4,655,382.02	4,732,919.81
	2022	2023	2024	2025	2026
Issuer .....	500,000,000.00	500,000,000.00	0.00	0.00	400,000,000.00
Gaselwest.....	41,918,666.12	42,899,741.65	34,580,266.89	26,311,589.00	22,277,801.81
IMEA .....	15,732,805.37	16,134,097.88	12,275,969.25	10,114,108.32	9,144,915.04
Imewo .....	45,059,164.47	46,276,779.85	37,372,694.58	28,276,205.32	21,514,339.22
Intergem.....	21,040,903.75	21,585,829.69	17,054,238.19	13,315,578.33	12,661,530.86
Iveka .....	28,488,905.81	29,236,352.14	23,067,889.50	17,739,224.47	14,532,309.96

<sup>64</sup> Long-term and short-term interest bearing loans divided by equity.

<sup>65</sup> Long-term and short-term interest bearing loans and borrowings as a percentage of total assets

	2022	2023	2024	2025	2026
Iverlek.....	36,080,721.33	37,026,178.16	29,187,313.79	21,549,523.34	18,813,237.80
Sibelgas.....	4,841,193.74	4,965,457.16	3,445,877.07	3,202,884.88	2,659,104.09
	2027	2028	2029	2030	2031
Issuer .....	50,000,000.00	54,500,000.00	550,000,000.00	0.00	0.00
Gaselwest.....	15,125,837.44	11,731,813.41	11,952,694.70	8,892,454.81	7,530,844.17
IMEA.....	5,653,216.60	4,198,045.37	4,269,698.82	3,166,896.64	2,927,801.80
Imewo.....	14,854,645.79	12,926,297.42	13,187,516.21	9,959,963.19	7,853,634.07
Intergem.....	8,077,100.65	6,376,889.75	6,506,512.33	5,265,446.92	4,184,528.74
Iveka.....	9,623,288.57	7,736,663.32	7,872,927.30	5,648,426.68	5,075,537.22
Iverlek.....	12,741,239.94	10,698,236.74	10,910,032.09	8,140,242.73	6,549,254.67
Sibelgas.....	1,679,554.58	1,273,440.14	1,294,331.17	862,862.08	823,199.26
	2032	2033	2034	2035	2036
Issuer .....	135,500,000.00	20,500,000.00	95,000,000.00	0.00	23,000,000.00
Gaselwest.....	7,642,020.53	7,758,975.20	7,875,091.91	7,992,728.58	2,814,332.67
IMEA.....	2,970,981.63	3,016,307.07	3,061,365.97	3,107,018.78	1,221,448.93
Imewo.....	7,969,418.13	8,090,856.39	8,211,639.21	8,334,018.10	3,404,342.44
Intergem.....	4,246,208.96	4,310,875.48	4,375,208.22	4,440,392.18	1,847,173.65
Iveka.....	5,150,458.07	5,229,253.78	5,307,496.18	5,386,763.59	1,921,460.60
Iverlek.....	6,645,844.68	6,747,234.94	6,848,028.57	6,950,150.70	2,731,474.10
Sibelgas.....	835,339.19	848,080.60	860,748.13	873,582.71	345,720.06
	2037	2038	2039	2040	2041
Issuer .....	0.00	0.00	0.00	0.00	0.00
Gaselwest.....	0.00	0.00	0.00	0.00	0.00
IMEA.....	0.00	0.00	0.00	0.00	0.00
Imewo.....	0.00	0.00	0.00	0.00	0.00
Intergem.....	0.00	0.00	0.00	0.00	0.00
Iveka.....	0.00	0.00	0.00	0.00	0.00
Iverlek.....	0.00	0.00	0.00	0.00	0.00
Sibelgas.....	0.00	0.00	0.00	0.00	0.00
	2042	2043	2044	2045	2046
Issuer .....	0.00	50,000,000.00	222,000,000.00	0.00	0.00
Gaselwest.....	0.00	0.00	0.00	0.00	0.00
IMEA.....	0.00	0.00	0.00	0.00	0.00
Imewo.....	0.00	0.00	0.00	0.00	0.00
Intergem.....	0.00	0.00	0.00	0.00	0.00
Iveka.....	0.00	0.00	0.00	0.00	0.00
Iverlek.....	0.00	0.00	0.00	0.00	0.00
Sibelgas.....	0.00	0.00	0.00	0.00	0.00

## 2.7 *Additional clarifications with regard to the information included in the financial statements of the Issuer and the Eandis Economic Group*

### *Pensions*

In the income statement, the expense relating to the defined benefit plan is presented net of the amount recognised for the disbursement received from the DSOs (which are equal). As the reimbursement right (which is accounted for as an asset), exactly matches the amount and timing of all of the benefits payable, the fair value of the asset is determined as the present value of the related obligation, and excludes any reduction as the reimbursement is recoverable in full.

As changes in the fair value of the reimbursement right are treated in the same way as changes in the fair value of plan assets, the movement in "other comprehensive income" for the pension liability following the impact of actuarial gains and losses, is also recognized in "other comprehensive income" for the reimbursement right as well all expenses and liabilities are fully recoverable from the DSOs (one-on-one relationship).

### *Related party transactions*

As indicated in this Prospectus, Eandis System Operator is the operating company of the Guarantors, and invoices the Guarantors at cost for its services. The aggregate amount of such

invoices amounted, for the financial year ended 31 December 2016, to EUR 970 million. Five of the Guarantors represent more than 10% each of such amount.

*Credit risk of the Issuer on the Guarantors*

As the proceeds of debt financing contracted by the Issuer are (to the extent not used for refinancing of the existing indebtedness of the Issuer) on-lent to the Guarantors, and further to the fact that the Issuer invoices the Guarantors for its services, the Issuer has important receivables outstanding on the Guarantors.

From the perspective of the Issuer, each of the Guarantors has the same credit risk. This is primarily due to the following circumstances, (i) each Guarantor has the aim to have the same proportion between equity and the Regulated Asset Base (ie 40%), which is the recommended proportion in the VREG tariff methodology for the remuneration of own funds, globally, the Eandis Economic Group aims for a ratio net debt / RAB < 70%, all Guarantors have the same income and cost structure; this follows from the tariff methodology, as well as the repatriation of costs by the Issuer; this is again subject to annual reporting (and approval) by the VREG), (iv) the current set-up was organically grown (often through mergers of other entities, and not deliberately set-up from the perspective of optimisation), (v) the strategic decisions being taken for the full Eandis Economic Group, there is unity of leadership and direction, and the same risk management processes are in place for each of the Guarantors, and (vi) the Guarantors obtain their revenue from the suppliers of energy, who are all subject to the same regulatory requirements in respect of credit quality, and who eventually invoice the end customers in the Flemish market (in which respect it is noted that the entities to which each DSO is exposed operate in (and, hence, the credit risk of the DSOs is influenced by) the entire Flemish market where the Issuer considers that there are no significant differences in credit quality between the end-customers in Flanders,

## PART XI – USE OF PROCEEDS

The net proceeds of the Bonds will be used primarily for the refinancing of the 2010-2017 4.00 per cent bond (EUR 150 million) which matures on 23 June 2017.

If the aggregate amount for which Bonds are issued exceeds EUR 150 million, such amount will be used by the Issuer to lend these amounts to the Guarantors to finance (in part and in addition to the auto-financing capabilities of the Issuer) the recurrent investments for grid maintenance and grid expansion provided for in the investment plan of the Eandis Economic Group (which was approved by the VREG). Please refer to section 7 of "*Part IX – Description of the Issuer and the Guarantors*" for information on the contemplated investments by the Eandis Economic Group. The specific projects that will be financed through such proceeds have not yet been determined.

The net proceeds of the issue are expected to amount to EUR 149,795,000 (expensed deducted) (in case the aggregate amount for which Bonds are issued is EUR 150,000,000) or EUR 199,795,000 (expensed deducted) (in case the aggregate amount for which Bonds are issued is EUR 200,000,000). The expenses in relation to the Public Offer, including the costs and fees, are expected to amount to EUR 205,000.



## PART XII – TAXATION

The following is a general description of the principal Belgian tax consequences for investors receiving interest in respect of, or disposing of, the Bonds and is of a general nature. This general description is based upon the law as in effect on the date of this Prospectus and is subject to any changes in law occurring after such date

The following summary does not purport to be a comprehensive description of all the tax considerations which may be relevant to a decision to subscribe for, purchase, own or dispose of the Bonds and does not purport to deal with the tax consequences applicable to all categories of investors, some of which (such as dealers in securities or commodities) may be subject to special rules. Prospective purchasers of the Bonds are advised to consult their own tax advisers concerning the overall tax consequences of their ownership of the Bonds.

### 1. **Belgian withholding tax**

#### 1.1 **General**

All payments by or on behalf of the Issuer of interest on the Bonds are in principle subject to the 30 per cent Belgian withholding tax on the gross amount of the interest. Tax treaties may provide for lower rates subject to certain conditions and formalities.

In this regard, "**interest**" means (i) the periodic interest income, (ii) any amount paid by the Issuer in excess of the issue price (whether or not on the maturity date) and, (iii) in case of a realisation of the Bonds between two interest payment dates, the *pro rata* of accrued interest corresponding to the detention period.

#### 1.2 **NBB-SSS of the National Bank of Belgium**

However, payments of interest and principal under the Bonds by or on behalf of the Issuer may be made without deduction of withholding tax in respect of the Bonds if and as long as at the moment of payment or attribution of interest they are held by the "**Eligible Investors**" in an exempt securities account (an "**X Account**") that has been opened with a financial institution that is a direct or indirect participant (a "**Participant**") in the NBB-SSS (the "**NBB-SSS**") operated by the National Bank of Belgium (the "**NBB**"). Euroclear and Clearstream, Luxembourg, are directly or indirectly Participants for this purpose.

Holding the Bonds through the NBB-SSS enables Eligible Investors to receive the gross interest income on their Bonds and to transfer the Bonds on a gross basis. Participants to the NBB-SSS must enter the Bonds which they hold on behalf of Eligible Investors in an X Account.

Eligible Investors are those entities referred to in article 4 of the Belgian Royal Decree of 26 May 1994 on the deduction of withholding tax (*koninklijk besluit van 26 mei 1994 over de inhouding en de vergoeding van de roerende voorheffing/arrêté royal du 26 mai 1994 relatif à la perception et à la bonification du précompte mobilier*) which include, *inter alia*:

- (a) Belgian corporations subject to Belgian corporate income tax;
- (b) institutions, associations or companies specified in article 2, §3 of the law of 9 July 1975 on the control of insurance companies other than those referred to in 1° and 3° subject to the application of article 262, 1° and 5° of the Belgian Income Tax Code of 1992 (*wetboek van inkomstenbelastingen 1992/code des impôts sur les revenus 1992*);
- (c) state regulated institutions (*parastatalen/institutions parastatales*) for social security, or institutions which are assimilated therewith, provided for in article 105, 2° of the Royal Decree implementing the Belgian Income Tax Code 1992 (*koninklijk besluit tot uitvoering van het wetboek inkomsten belastingen 1992/arrêté royal d'exécution du code des impôts sur les revenus 1992*);
- (d) non-resident Investors provided for in article 105, 5° of the same decree;

- (e) investment funds, recognised in the framework of pension savings, provided for in article 115 of the same decree;
- (f) tax payers provided for in article 227, 2° of the Belgian Income Tax Code 1992 which have used the income generating capital for the exercise of their professional activities in Belgium and which are subject to non-resident income tax pursuant to article 233 of the same code;
- (g) the Belgian State in respect of investments which are exempt from withholding tax in accordance with article 265 of the Belgian Income Tax Code 1992;
- (h) investment funds governed by foreign law which are an indivisible estate managed by a management company for the account of the participants, provided the fund units are not offered publicly in Belgium or traded in Belgium; and
- (i) Belgian resident corporations, not provided for under (a), when their activities exclusively or principally consist of the granting of credits and loans.

Eligible Investors do not include, *inter alia*, Belgian resident Investors who are individuals or non-profit making organisations, other than those mentioned under (b) and (c) above.

Participants to the NBB-SSS must keep the Bonds which they hold on behalf of the non-Eligible Investors in a non-exempt securities account (an "**N Account**"). In such instance all payments of interest are subject to the 30 per cent withholding tax. This withholding tax is withheld by the NBB and paid to the Belgian Treasury.

Transfers of Bonds between an X Account and an N Account give rise to certain adjustment payments on account of withholding tax:

- A transfer from an N Account to an X Account gives rise to the payment by the transferor non-Eligible Investor to the NBB of withholding tax on the accrued fraction of interest calculated from the last interest payment date up to the transfer date.
- A transfer from an X Account to an N Account gives rise to the refund by the NBB to the transferee non-Eligible Investor of withholding tax on the accrued fraction of interest calculated from the last interest payment date up to the transfer date.
- Transfers of Bonds between two X Accounts do not give rise to any adjustment on account of withholding tax.

Transfers of Bonds between two N-accounts give rise to the payment by the transferor non-Eligible Investor to the NBB of withholding tax on the accrued fraction of interest calculated from the last interest payment date up to the transfer date, and to the refund by the NBB to the transferee non-Eligible Investor of withholding tax on the same interest amount.

Upon opening of an X Account for the holding of Bonds, the Eligible Investor is required to provide the Participant with a statement of its eligible status on a form approved by the Minister of Finance. There is no ongoing declaration requirement to the NBB-SSS as to the eligible status.

An X Account may be opened with a Participant by an intermediary (an "**Intermediary**") in respect of Bonds that the Intermediary holds for the account of its clients (the "**Beneficial Owners**"), **provided that** each Beneficial Owner is an Eligible Investor. In such a case, the Intermediary must deliver to the Participant a statement on a form approved by the Minister of Finance confirming that (i) the Intermediary is itself an Eligible Investor and (ii) the Beneficial Owners holding their Bonds through it are also Eligible Investors. A Beneficial Owner is also required to deliver a statement of its eligible status to the intermediary.

These identification requirements do not apply to Bonds held in Euroclear or Clearstream, Luxembourg as Participants to the NBB-SSS, **provided that** Euroclear or Clearstream, Luxembourg only hold X Accounts and that they are able to identify the holders for whom they hold Bonds in such account.

In accordance with the NBB-SSS, a Bondholder who is withdrawing Bonds from an X Account will, following the payment of interest on those Bonds, be entitled to claim an indemnity from the Belgian tax authorities of an amount equal to the withholding on the interest payable on the Bonds from the last preceding Interest Payment Date until the date of withdrawal of the Bonds from the NBB-SSS. As a condition of acceptance of the Bonds into the NBB-SSS, the Bondholders waive the right to claim such indemnity.

## **2. Belgian tax on income and capital gains**

### **2.1 *Belgian resident individuals***

For natural persons who are Belgian residents for tax purposes, i.e., which are subject to the Belgian personal income tax (*personenbelastingen/impôt des personnes physiques*) and who hold the Bonds as a private investment, payments of interest on the Bonds will in principle be subject to a 30 per cent withholding tax. The Belgian withholding tax constitutes the final income tax for Belgian resident individuals. This means that they do not have to declare the interest obtained on the Bonds in their personal income tax return.

Belgian residents may nevertheless opt to declare interest in respect of the Bonds in their personal income tax return. Where the beneficiary opts to declare the interest, these payments will in principle be taxed at a flat rate of 30 per cent (or at the relevant progressive personal income tax rate(s) taking into account the taxpayer's other declared income, whichever is more beneficial). If the interest payments are declared, the withholding tax may be credited.

Capital gains realised on the sale of the Bonds are in principle tax exempt, unless the capital gains are realised outside the scope of the management of one's private estate or unless the capital gains qualify as interest (as defined in section 1.1 above). Capital losses realised upon the disposal of the Bonds held as non-professional investment are in principle not tax deductible.

Other tax rules apply to Belgian resident individuals who do not hold the Bonds as a private investment.

### **2.2 *Belgian resident companies***

Interest attributed or paid to corporate Bondholders who are Belgian residents for tax purposes, i.e., who are subject to the Belgian Corporate Income Tax (*vennootschapsbelasting/impôt des sociétés*), as well as capital gains realised upon the sale of the Bonds are taxable at the ordinary corporate income tax rate of in principle 33.99 per cent. Capital losses realised upon the sale of the Bonds are in principle tax deductible.

Other tax rules apply to investment companies within the meaning of article 185*bis* of the Belgian Income Tax Code.

### **2.3 *Belgian resident legal entities***

Belgian legal entities subject to the Belgian legal entities tax (*rechtspersonenbelasting/impôt des personnes morales*) which do not qualify as Eligible Investors (as defined in section 1.2 above) are subject to a withholding tax of 30 per cent on interest payments. The withholding tax constitutes the final taxation.

Belgian legal entities which qualify as Eligible Investors (as defined in section 1.2 above) and which consequently have received gross interest income are required to declare and pay the 30 per cent withholding tax to the Belgian tax authorities.

Capital gains realised on the sale of the Bonds are in principle tax exempt, unless the capital gains qualify as interest (as defined section 1.1 above). Capital losses are in principle not tax deductible.

### **2.4 *Organisations for Financing Pensions***

Interest and capital gains derived by Organisations for Financing Pensions (*Organismen voor de Financiering van Pensioenen/Organismes de Financement de Pensions*) within the meaning of

the Belgian law of 27 October 2006 on the activities and supervision of institutions for occupational retirement provision (*Wet van 27 oktober 2006 betreffende het toezicht op de instellingen voor bedrijfspensioenvoorzieningen/Loi du 27 octobre 2006 relative au contrôle des institutions de retraite professionnelle*), are in principle exempt from Belgian corporate income tax. Capital losses are in principle not tax deductible. Subject to certain conditions, the Belgian withholding tax that has been levied can be credited against any corporate income tax due and any excess amount is in principle refundable.

## 2.5 *Non-residents of Belgium*

Bondholders who are not residents of Belgium for Belgian tax purposes and who are not holding the Bonds through their permanent establishment in Belgium, will not become liable for any Belgian tax on income or capital gains by reason only of the acquisition or disposal of the Bonds **provided that** they qualify as Eligible Investors and that they hold their Bonds in an X Account.

## 3. **Tax on stock exchange transactions**

A tax on stock exchange transactions (*taks op de beursverrichtingen/taxe sur les opérations de bourse*) will be levied on the acquisition and disposal of Bonds on the secondary market if executed in Belgium through a professional intermediary. The tax is due at a rate of 0.09 per cent on each acquisition and disposal separately, with a maximum amount of EUR 1,300 per transaction and per party and collected by the professional intermediary. No transfer will be due on the issuance of the Bonds (primary market).

Following the Law of 25 December 2016, the scope of application of the tax on the stock exchange transactions has been extended as of 1 January 2017 to secondary market transactions of which the order is directly or indirectly made to a professional intermediary established outside Belgium by (i) a private individual with habitual residence in Belgium or (ii) a legal entity for the account of its seat or establishment in Belgium (both referred to as a "**Belgian Investor**"). In such case, the tax on the stock exchange transactions is payable by the Belgian Investor unless the Belgian Investor can demonstrate that the tax on the stock exchange transactions has already been paid by the professional intermediary established outside Belgium. Professional intermediaries established outside of Belgium could however appoint a stock exchange tax representative in Belgium, subject to certain conditions and formalities ("**Stock Exchange Tax Representative**"). Such Stock Exchange Tax Representative will then be required to pay the Belgian Treasury the tax on stock exchange transactions and to comply with reporting obligations in that respect. If such Stock Exchange Tax Representative has paid the tax on stock exchange transactions, the Belgian Investor will, as per the above, no longer be required to pay the tax on stock exchange transactions.

A tax on repurchase transactions (*taks op de reporten/taxe sur les reports*) at the rate of 0.085 per cent will be due from each party to any such transaction entered into or settled in Belgium in which a stockbroker acts for either party (with a maximum amount of EUR 1,300 per transaction and per party).

However neither of the taxes referred to above will be payable by exempt persons acting for their own account, including investors who are not Belgian residents, provided they deliver an affidavit to the financial intermediary in Belgium confirming their non-resident status, and certain Belgian institutional investors as defined in article 126.1 2° of the code of miscellaneous duties and taxes (*Wetboek diverse rechten en taksen/Code des droits et taxes divers*) for the tax on stock exchange transactions and article 139, second paragraph, of the same code for the tax on repurchase transactions.

As stated below, the EU Commission adopted on 14 February 2013 a proposal for a Council Directive (the "**Draft Directive**") on a common financial transaction tax ("**FTT**"). The Draft Directive currently stipulates that once the FTT enters into force, the Participating Member States shall not maintain or introduce taxes on financial transactions other than the FTT (or VAT as provided in the Council Directive 2006/112/EC of 28 November 2006 on the common system of value added tax). For Belgium, the tax on stock exchange transactions should thus be abolished once the FTT enters into force. The Draft Directive is still subject to negotiation between the Participating Member States and therefore may be changed at any time.

#### 4. **The proposed Financial Transaction Tax**

The EU Commission adopted on 14 February 2013 the Draft Directive implementing enhanced cooperation in the area of financial transactions tax. Pursuant to the Draft Directive, the FTT shall be implemented and enter into effect in eleven EU Member States (Austria, Belgium, Estonia, France, Germany, Greece, Italy, Portugal, Slovakia, Slovenia and Spain on 1 January 2014. In December 2015, Estonia withdrew from the group of states willing to introduce the FTT (the "**Participating Member States**").

According to the Draft Directive, the FTT shall be payable on financial transactions **provided that** at least one party to the financial transaction is established (or deemed established) in a Participating Member State and that there is a financial institution established (or deemed established) in a Participating Member State which is a party to the financial transaction, or is acting in the name of a party to the transaction. The FTT shall, however, not apply to among others primary market transactions referred to in Article 5 (c) of Regulation (EC) No 1287/2006, including the activity of underwriting and subsequent allocation of financial instruments in the framework of their issue.

The rates of the FTT shall be fixed by each Participating Member State but for transactions involving financial instruments other than derivatives they shall amount to at least 0.1 per cent of the taxable amount. The taxable amount for such transactions shall in general be determined by reference to the consideration paid or owed in return for the transfer or the market price (whichever is higher). The FTT shall be payable by each financial institution established (or deemed established) in a Participating Member State which is a party to the financial transaction, which is acting in the name of a party to the transaction or where the transaction has been carried out on its account. Where the FTT due has not been paid within the applicable time limits, each party to the relevant financial transaction, including persons other than financial institutions, shall become jointly and severally liable for the payment of the FTT due.

Prospective Holders should therefore note, in particular, that if the Draft Directive is implemented by the Participating Member States in its current form, any sale, purchase or exchange of the Bonds will be subject to the FTT at a minimum rate of 0.1 per cent, provided the abovementioned prerequisites are met. The Holder may be liable to itself pay this charge or reimburse a financial institution for the charge, and/or the charge may affect the value of the Bonds.

The Draft Directive is still subject to negotiation between the Participating Member States and therefore may be changed at any time. Moreover, if and once the Draft Directive has been adopted and becomes a directive (the "**Directive**"), it will need to be implemented into the respective domestic laws of the Participating Member States and the domestic provisions implementing the Directive might deviate from the Directive itself. Furthermore, it should be noted that on 18 April 2013 the United Kingdom challenged the legality of the FTT before the European Court of Justice. This legal challenge has, however, no suspending effect. Prospective Holders of the Bonds should consult their own tax advisers in relation to the consequences of the FTT associated with the subscription, purchase, holding or disposal of the Bonds.

#### 5. **FATCA Withholding**

Pursuant to certain provisions of the U.S. Internal Revenue Code of 1986, commonly known as FATCA, a "foreign financial institution" may be required to withhold on certain payments it makes ("foreign passthru payments") to persons that fail to meet certain certification, reporting, or related requirements. A number of jurisdictions (including Belgium) have entered into, or have agreed in substance to, intergovernmental agreements with the United States to implement FATCA ("IGAs"), which modify the way in which FATCA applies in their jurisdictions. Certain aspects of the application of the FATCA provisions and IGAs to instruments such as the Notes, including whether withholding would ever be required pursuant to FATCA or an IGA with respect to payments on instruments such as the Bonds, are uncertain and may be subject to change. Even if withholding would be required pursuant to FATCA or an IGA with respect to payments on instruments such as the Bonds, such withholding would not apply prior to 1 January 2019. Additionally, Bonds that are not treated as equity for U.S. federal income tax purposes and that have a fixed term that are issued on or prior to the date that is six months after the date on

which final regulations defining "foreign passthru payments" are filed with the U.S. Federal Register generally would be "grandfathered" for purposes of FATCA withholding unless materially modified after such date.

However, if additional Bonds (as described under "*Terms and Conditions of the Bonds – Further Issues*") that are not distinguishable from previously issued Bonds are issued after the expiration of the grandfathering period and are subject to withholding under FATCA, then withholding agents may treat all Bonds, including the Bonds offered prior to the expiration of the grandfathering period, as subject to withholding under FATCA. Holders should consult their own tax advisors regarding how these rules may apply to their investment in the Bonds. In the event any withholding would be required pursuant to FATCA or an IGA with respect to payments on the Bonds, no person will be required to pay additional amounts as a result of the withholding.

## PART XIII– SUBSCRIPTION AND SALE

Belfius Bank NV/SA (having its registered office at Pachecolaan 44, 1000 Brussels, Belgium and registered with the Crossroads Bank for Enterprises (*Kruispuntbank van Ondernemingen/Banque-Carrefour des Entreprises*) under number 0403.201.185) ("**Belfius**") and BNP Paribas Fortis NV/SA (having its registered office at Warandeberg 3, 1000 Brussels, Belgium and registered with the Crossroads Bank for Enterprises (*Kruispuntbank van Ondernemingen/Banque-Carrefour des Entreprises*) under number 0403.199.702) ("**BNP Paribas Fortis**") are acting as joint lead managers (together the "**Joint Lead Managers**" and each a "**Joint Lead Manager**"). The Joint Lead Managers have, pursuant to a placement agreement dated on or about 6 June 2017 (the "**Placement Agreement**"), agreed with the Issuer, subject to certain terms and conditions, to use best efforts to place the Bonds in a minimum amount of EUR 150,000,000 and a maximum amount of EUR 200,000,000 with third parties at the Issue Price and at the conditions specified below. Belfius has also been appointed as domiciliary, calculation, paying and listing agent for the purposes of the Public Offer in Belgium.

**This section contains the terms and conditions of the Public Offer of the Bonds by the Joint Lead Managers. Each offer and sale of the Bonds by any financial intermediary (other than the Joint Lead Managers) authorised pursuant to Directive 2004/39/EC to conduct such offers (each an "Authorised Offeror") will be made in accordance with the terms and conditions as agreed between an Authorised Offeror and an investor, including in relation to the price, the allocation and the costs and/or taxes to be borne by an investor. Neither the Issuer nor any of the Guarantors are a party to any arrangements or terms and conditions in connection with the offer and sale of the Bonds between the Authorised Offeror and an investor. This Prospectus does not contain the terms and conditions of any Authorised Offeror. The terms and conditions in connection with the offer and sale of the Bonds will be provided to any investor by an Authorised Offeror during the Subscription Period. Neither the Issuer nor any of the Guarantors or the Joint Lead Managers can be held responsible or liable for any such information.**

Each of the services provided by the Joint Lead Managers may be granted by any Joint Lead Manager acting through any of its branches, affiliates or related companies, and all references to "*Joint Lead Managers*" herein will be understood as to include such branches and affiliated companies, to the extent that such services are provided by such entities.

### 1. **Subscription Period**

The Bonds will be offered to the public in Belgium (the "**Public Offer**") during the Subscription Period (as defined below). The Joint Lead Managers expect to offer the Bonds to qualified investors (as defined in the Prospectus Law, the "**Qualified Investors**") and to investors who are not Qualified Investors (the "**Retail Investors**"). The Bonds will be issued on 23 June 2017 (the "**Issue Date**"). However, in case a supplement to the Prospectus gives rise to withdrawal rights exercisable on or after the Issue Date of the Bonds in accordance with article 34 of the Prospectus Law, the Issue Date will be postponed until the first business day following the last day on which the withdrawal rights may be exercised. Orders by investors to purchase the Bonds are irrevocable, provided that investors who have already agreed to purchase or subscribe to securities before the publication of the supplement to the Prospectus have the right to withdraw their agreement during a period of two business days commencing on the day after the publication of the supplement.

The Public Offer will start on 9 June 2017 at 9 a.m. (Brussels time) and end on 16 June 2017 at 5.30 p.m. (Brussels time) (the "**Subscription Period**"), or such earlier date as the Issuer may determine in agreement with the Joint Lead Managers. In this case, such closing date will be announced by or on behalf of the Issuer, on its website (within the section addressed to investors as "**Investor Relations**") ([www.eandis.be](http://www.eandis.be)), and on the website of the Joint Lead Managers ([www.belfius.be/eandis](http://www.belfius.be/eandis) and [www.bnpparibasfortis.be](http://www.bnpparibasfortis.be)).

Except in case of oversubscription as set out below under paragraph 10 (*Allotment and over-subscription in the Bonds*), a prospective subscriber will receive 100% of the amount of the Bonds validly subscribed to it during the Subscription Period.

Prospective subscribers will be notified of their allocations of Bonds by the applicable financial intermediary in accordance with the arrangements in place between such financial intermediary and the prospective subscriber.

No dealings in the Bonds on a regulated market for the purposes of Directive 2004/39/EC of the European Parliament and of the Council of 21 April 2004 on markets in financial instruments amending Council Directives 85/611/EEC and 93/6/EEC and Directive 2000/12/EC of the European Parliament and of the Council and repealing Council Directive 93/22/EEC, as amended, may take place prior to the Issue Date.

After having read the entire Prospectus, the investors can subscribe to the Bonds through the branches of the following Joint Lead Managers appointed by the Issuer, using the subscription form provided by the Joint Lead Managers (if any): Belfius Bank NV/SA ([www.belfius.be/eandis](http://www.belfius.be/eandis)) and BNP Paribas Fortis NV/SA ([www.bnpparibasfortis.be](http://www.bnpparibasfortis.be)) at the Issue Price set out below, with no additional commission or costs being charged.

The applications can also be submitted through agents or any other financial intermediaries in Belgium. In this case, the investors must obtain information concerning the commission fees that the financial intermediaries can charge. These commission fees are charged to the investors. For an overview of the commissions see section 3 (*Issue Price*) below.

## 2. **Conditions to which the Public Offer is subject**

The Public Offer and the issue of the Bonds is subject to a limited number of conditions set out in the Placement Agreement, which are customary for this type of transaction, and which include, amongst others: (i) the correctness of the representations and warranties made by the Issuer and the Guarantors in the Placement Agreement, (ii) the Placement Agreement, the Clearing Services Agreement and the Agency Agreement having been executed by all parties thereto prior to the Issue Date, (iii) the admission to trading of the Bonds on the regulated market of Euronext Brussels having been granted on or prior to the Issue Date, (iv) there having been, as at the Issue Date, no Material Adverse Change (as defined in the Placement Agreement) affecting the Issuer, its Subsidiaries and the Guarantors and no event making any of the representations and warranties contained in the Placement Agreement untrue or incorrect on the Issue Date as if they had been given and made on such date and the Issuer and the Guarantors having performed all the obligations to be performed by it under the Placement Agreement on or before the Issue Date and (v) at the latest on the Issue Date, the Joint Lead Managers having received customary confirmations as to certain legal and financial matters pertaining to the Issuer and the Guarantors.

These conditions can be waived (in whole or in part) by each of the Joint Lead Managers. The Placement Agreement does not entitle the Joint Lead Managers to terminate their obligations prior to payment being made to the Issuer, except in certain limited circumstances.

If the terms of the Public Offer and the subsequent issuance of the Bonds are not met on the Issue Date (subject to waiver by the Joint Lead Managers of the conditions that could not be fulfilled) or any Joint Lead Manager terminates the Placement Agreement in one of the circumstances mentioned above, the Bonds will not be issued. Termination of the Placement Agreement by one of the Joint Lead Managers does not trigger the termination of the Placement Agreement for the other Joint Lead Managers, but there is no obligation for the non-terminating Joint Lead Managers to place the Bonds assigned to the terminating Joint Lead Manager. In case of cancellation of the Public Offer, a notice will be published on the website of the Issuer ([www.eandis.be](http://www.eandis.be)) and on the websites of the Joint Lead Managers: Belfius Bank NV/SA ([www.belfius.be/eandis](http://www.belfius.be/eandis)) and BNP Paribas Fortis NV/SA ([www.bnpparibasfortis.be](http://www.bnpparibasfortis.be)) and the total amount of funds already paid by investors for the Bonds will be reimbursed. For the avoidance of doubt, no interest will accrue on such amount.

## 3. **Issue Price**

The issue price for the Bonds will be 101.875 per cent (the "**Issue Price**").

The Retail Investors will pay the Issue Price.



The Qualified Investors will pay the Issue Price that includes a distribution commission of 1.875 per cent less a discount, such resulting price being subject to change during the Subscription Period based, among others, on (i) the evolution of the credit quality of the Issuer (credit spread), (ii) the evolution of interest rates, (iii) the success (or lack of success) of the placement of the Bonds, (iv) the amount of Bonds purchased by an investor and (v) the priority given to Qualified Investors acting as intermediaries for onward placement towards Retail Investors, each as determined by the Joint Lead Managers in their sole discretion. The discount on the distribution commission paid by the qualified investors will range between 0.50 and 0.75 per cent.

The net yield of the Bonds is 1.153 per cent on an annual basis. The yield is calculated on the basis of the issue of the Bonds on the Issue Date, the Issue Price, the interest rate of 2.000 per cent per annum and is based on the assumption that the Bonds will be held until 23 June 2025 when they will be repaid at 100 per cent of their principal amount in accordance with the Conditions. It is not an indication of future yield if the Bonds are not held until their maturity date. The net yield reflects a deduction of Belgian withholding tax at the rate of 30 per cent (Investors should consult "*Part XII – Taxation*" of the Prospectus).

The minimum amount of application for the Bonds is EUR 500. The maximum amount of application is the Aggregate Nominal Amount.

#### 4. **Aggregate Nominal Amount**

The minimum nominal amount of the issue amounts to EUR 150,000,000 and the maximum nominal amount amounts to EUR 200,000,000.

The criteria in accordance with which the final aggregate nominal amount of the Bonds will be determined by the Issuer are the following: (i) the funding needs of the Issuer, which could evolve during the Subscription Period for the Bonds, (ii) the levels of the interest rates and the credit spread of the Issuer on a daily basis, (iii) the level of demand from investors for the Bonds as observed by the Joint Lead Managers on a daily basis, (iv) the occurrence or not of certain events during the Subscription Period of the Bonds giving the possibility to the Issuer and/or the Joint Lead Managers to early terminate the Subscription Period or to not proceed with the Public Offer and the issue of the Bonds and (v) the fact that the minimum principal amount of the Bonds is EUR 150,000,000 and that the maximum principal amount of the Bonds is EUR 200,000,000.

The Issuer has reserved the right not to proceed with the issue of the Bonds if at the end of the Subscription Period, the aggregate principal amount of the Bonds that have been subscribed for is lower than EUR 150,000,000.

The final aggregate nominal amount shall be published as soon as possible after the end (or the early closing) of the Subscription Period by the Issuer, on its website (within the section addressed to investors as "**Investor Relations**") ([www.eandis.be](http://www.eandis.be)), and on the website of the Joint Lead Managers ([www.belfius.be/eandis](http://www.belfius.be/eandis) and [www.bnpparibasfortis.be](http://www.bnpparibasfortis.be)).

#### 5. **Payment date and details**

The payment date is 23 June 2017. The payment for the Bonds can only occur by means of debiting from a deposit account.

On the date that the subscriptions are settled, the NBB-SSS will credit the custody account of the Domiciliary Agent according to the details specified in the rules of the NBB-SSS.

Subsequently, the Domiciliary Agent, at the latest on the payment date, will credit the amounts of the subscribed Bonds to the account of the participants for onward distribution to the subscribers, in accordance with the usual operating rules of the NBB-SSS.

#### 6. **Costs and fees**

The net proceeds (before deduction of expenses) will be an amount equal to the aggregate nominal amount of the Bonds issued (the "**Aggregate Nominal Amount**") multiplied by the Issue Price expressed in percentage, minus the total selling and distribution commission of 1.875 per cent (borne by the subscribers).

The Issue Price shall include the selling and distribution commission described below, such commission being borne and paid by the subscribers.

Expenses specifically charged to the subscribers at the time of subscription:

- (i) the Retail Investors will bear a selling and distribution commission of 1.875 per cent, included in the Issue Price; and
- (ii) the Qualified Investors will bear a distribution commission of 1.875 per cent, subject to the discount foreseen in section 3 above. The discount on the distribution commission paid by the Qualified Investors will range between 0.50 and 0.75 per cent.

After subscription, the financial services in relation to the Bonds will be provided free of charge by the Joint Lead Managers.

The subscribers may be charged costs after subscription, including the costs for the custody fee for the Bonds and costs in relation to brokers. The exercise by an investor of the put option provided in Condition 5(b) (*Redemption at the option of the Bondholders following a Change of Control*) may give rise to further costs for the investor, and investors should enquire their Financial Intermediary about such costs prior to exercising such put option.

Investors must inform themselves about the costs their financial institutions might charge them. Such information is available in the brochures on tariffs on the relevant websites of the Joint Lead Managers. Investors must furthermore inform themselves about the costs which the other financial institutions might charge them.

Investors may be subject to taxes such as withholding taxes and a tax on stock exchange transactions. Please refer to "*Part XIII - Taxation*" of the Prospectus for more information.

All costs of the Issuer relating to the issue of the Bonds, including legal costs, are borne by the Issuer.

#### 7. **The Calculation Agent**

Belfius will act as Calculation Agent of the Issuer in accordance with the provisions of the Agency Agreement.

#### 8. **Early closure and reduction**

Early termination of the Subscription Period will intervene at the earliest on 9 June 2017 at 5.30 p.m. (Brussels time) (the minimum Subscription Period is referred to as the "**Minimum Sales Period**") (this is the third business day in Belgium following the day on which the Prospectus has been made available on the websites of the Issuer and the Joint Lead Managers (including the day on which the Prospectus was made available). This means that the Subscription Period will remain open at least one business day until 5.30 p.m. Thereafter, early termination can take place at any moment (including in the course of a business day). In case of early termination of the Subscription Period, a notice will be published as soon as possible on the websites of the Issuer ([www.eandis.be](http://www.eandis.be)) and Belfius ([www.belfius.be/eandis](http://www.belfius.be/eandis)) and BNP Paribas Fortis ([www.bnpparibasfortis.be](http://www.bnpparibasfortis.be)). This notice will specify the date and hour of the early termination.

The Subscription Period may be shortened by the Issuer during the Subscription Period with the consent of the Joint Lead Managers (i) as soon as the total amount of the Bonds reaches EUR 150,000,000 (as the Issuer may finance the contemplated investments also through its auto-finance capabilities), (ii) in the event that a major change in market conditions occurs (among others, but not limited to, a change in national or international financial, political or economic circumstances, exchange rates or interest rates) or (iii) in case a material adverse change occurs with respect to the condition (financial or otherwise), the prospects or the general affairs of the Issuer. In case the Subscription Period is terminated early as a result of the occurrence described under (ii) and (iii) in the preceding sentence and the total amount of EUR 150,000,000 is not yet reached, then the Issuer will publish a supplement to the Prospectus. The Issuer will ensure that any such supplement is published as soon as possible after the occurrence of such new significant

factor (see page v of the Prospectus under "*Warnings*" for further information with respect to the publication of supplements to the Prospectus).

The Issuer may, with the consent of the Joint Lead Managers, decide to limit the Aggregate Nominal Amount of the Bonds or reduce the Aggregate Nominal Amount below EUR 150,000,000 if the Subscription Period is closed early in accordance with the previous paragraph in response to a major change in market conditions (among others, but not limited to a change in national or international financial, political or economic circumstances, exchange rates or interest rates) or a material adverse change in the financial condition of the Issuer. In such case, the Issuer will ensure a supplement is published.

The Issuer has reserved the right not to proceed with the issue of the Bonds if at the end of the subscription period, the aggregate nominal amount of the Bonds that have been subscribed for is lower than EUR 150,000,000.

In addition, the offer is subject to specific conditions negotiated between the Joint Lead Managers and the Issuer that are included in the Placement Agreement, and in particular, the obligations of the Joint Lead Managers under the Placement Agreement could terminate, *inter alia*, as set out above.

#### 9. **Allotment and over-subscription in the Bonds**

The Joint Lead Managers, acting severally but not jointly, agree to place the Bonds on a best efforts basis. For an aggregate nominal amount of the Bonds of minimum EUR 150,000,000 and maximum EUR 200,000,000 (each of the amounts hereafter being increased or reduced proportionally in case the aggregate nominal amount of the Bonds to be issued is higher than EUR 150,000,000 and lower than EUR 200,000,000) (the "**Allocation Structure**"):

- (a) each of the Joint Lead Managers has the right to place an amount of EUR 60,000,000 in the case of an aggregate nominal amount of the Bonds of EUR 150,000,000 (40 per cent. each of 80 per cent. together of the aggregate nominal amount of the Bonds to be issued) exclusively with its own retail and private banking clients who are Retail Investors; or
- (b) each of the Joint Lead Managers has the right to place an amount of EUR 80,000,000 in case of an aggregate nominal amount of the Bonds of EUR 200,000,000 (40 per cent. each or 80 per cent. together of the aggregate nominal amount of the Bonds to be issued) exclusively with its own retail and private banking clients who are Retail Investors;

(the Bonds under (a) and (b) are collectively referred to as the "**Assigned Bonds**").

To the extent the Assigned Bonds allocated to one of the Joint Lead Managers are not fully placed by such Joint Lead Manager as observed at 5.30 p.m. (Brussels time) on the date being the first Business Day of the Subscription Period, then, upon notification to the Issuer and subject to its consent, the other Joint Lead Manager shall have the right (but not the obligation) to place such Assigned Bonds with its own retail and private banking clients who are Retail Investors.

To the extent not all of the unplaced Assigned Bonds are placed pursuant to the previous paragraph at 5.30 p.m. (Brussels time) on the date being the first Business Day of the Subscription Period, the Issuer shall have the right (but not the obligation) to authorise the Joint Lead Managers together to place on that day the Assigned Bonds unplaced pursuant to the previous paragraph exclusively to Qualified Investors at the Selling Price, as a pot deal and subject to the fee arrangements between the Joint Lead Managers. The Joint Lead Managers will privilege the allocation to those Qualified Investors acting as intermediaries for placement towards Retail Investors following the general consent contained in the Prospectus.

If after the procedure described under the two previous paragraphs not all Assigned Bonds are placed at 5.30 p.m. (Brussels time) on the date being the first Business Day of the Subscription Period, if applicable, the Joint Lead Managers each have the right to place half of the remaining unplaced Assigned Bonds exclusively with its own retail and private banking clients who are Retail Investors and the Subscription Period will be closed upon all such Bonds being placed. Each Joint Lead Manager will publish a notice on its website as soon as possible upon having placed all such Assigned Bonds, and the Subscription Period shall be terminated as soon as

possible upon each Joint Lead Manager having placed such Assigned Bonds with Retail Investors, which termination may occur during a business day. A notice will be published as soon as possible upon termination of the Subscription Period on the websites of the Joint Lead Managers and the Issuer, specifying the date and hour of the early termination.

Bonds other than the Assigned Bonds (being EUR 30,000,000 in the case of an expected aggregate nominal amount of the Bonds of EUR 150,000,000 (10 per cent. each or 20 per cent. together of the aggregate nominal amount of the Bonds to be issued) or EUR 40,000,000 in the case of an expected aggregate nominal amount of the Bonds of EUR 200,000,000 (10 per cent. each or 20 per cent. together of the aggregate nominal amount of the Bonds to be issued)) shall be placed exclusively with Qualified Investors at the Selling Price, as a pot deal and subject to the fee arrangements between the Joint Lead Managers. The Joint Lead Managers will privilege the allocation to those Qualified Investors acting as intermediaries for onward placement towards Retail Investors on the basis of the general consent contained in the Prospectus.

The Allocation Structure can only be amended if agreed between the Issuer and Joint Lead Managers.

Subscribers may have different re-assignment percentages applied to them depending on the Joint Lead Manager through which they have subscribed. Each of the Joint Lead Managers shall publish the applied reduction percentages on their website.

The Joint Lead Managers shall in no manner whatsoever be responsible for the allotment criteria that will be applied by other financial intermediaries. No subscription is possible before the start of the Subscription Period.

In case of early termination of the Subscription Period, the investors will be informed regarding the number of Bonds that have been allotted to them as soon as possible after the date of the early termination of the Subscription Period.

All subscriptions that have been validly introduced by the Retail Investors with the Joint Lead Managers before the end of the Minimum Sales Period will be taken into account when the Bonds are allotted, it being understood that in case of oversubscription, a reduction may apply, i.e., the subscriptions will be scaled back proportionally by each Joint Lead Manager, with an allocation of a multiple of EUR 500, which corresponds to the denomination of the Bonds. The portion of the Bonds assigned to be placed with Qualified Investors shall be allocated thereby giving priority to Qualified Investors for onward placement to Retail Investors. This privileged allocation may cause certain Qualified Investors to receive less than or none of the ordered Bonds.

Any payment made by a subscriber to the Bonds in connection with the subscription of Bonds which are not allotted will be refunded within seven Business Days (as defined in the Conditions of the Bonds) after the date of payment in accordance with the arrangements in place between such relevant subscriber and the relevant financial intermediary, and the relevant subscriber shall not be entitled to any interest in respect of such payments.

#### 10. **Results of the Public Offer**

The results of the offer of the Bonds (including its net proceeds) shall be published as soon as possible after the end of the Subscription Period and on or before the Issue Date by the Issuer, on its website (within the section addressed to investors as "**Investor Relations**") ([www.eandis.be](http://www.eandis.be)), and by the Joint Lead Managers ([www.belfius.be/eandis](http://www.belfius.be/eandis) and [www.bnpparibasfortis.be](http://www.bnpparibasfortis.be)). The same method of publication will be used to inform the investors in case of early termination of the Subscription Period. Furthermore, the amount of Bonds will be notified to the FSMA as soon as possible at the earlier of the end of the Subscription Period and the date of the early termination of the Subscription Period.

## 11. **Expected timetable of the Public Offer**

The main steps of the timetable of the Public Offer can be summarised as follows:

- 7 June 2017: publication of the Prospectus on the website of the Issuer and the Joint Lead Managers;
- 9 June 2017, 9 a.m. (Brussels time): opening date of the Subscription Period;
- 16 June 2017, 5.30 p.m. (Brussels time): closing date of the Subscription Period (if not closed earlier);
- between 16 June 2017 and 23 June 2017: expected publication date of the results of the offer of the Bonds (including its net proceeds) on the websites of the Joint Lead Managers, unless published earlier in case of early closing;
- 23 June 2017: Issue Date and listing of the Bonds on the regulated market of Euronext Brussels.

The dates and times of the Public Offer and periods indicated in the above timetable and throughout this Prospectus may change. Should the Issuer decide to amend such dates, times or periods, it will inform investors through a publication in the financial press. Any material alterations to this Prospectus are to be approved by the FSMA, and will be, in each case as and when required by applicable law, published in a press release, an advertisement in the financial press, and/or a supplement to this Prospectus.

## 12. **Transfer of the Bonds**

Subject to compliance with any applicable selling restrictions, the Bonds are freely transferable (see also Selling Restrictions below).

## 13. **Selling Restrictions**

### 13.1 ***Countries in which the Public Offer is open***

The Bonds are being offered only to investors to whom such offer can be lawfully made under any law applicable to those investors. The Issuer has taken necessary actions to ensure that Bonds may lawfully be offered to the public in Belgium. The Issuer has not taken any action to permit any offering of the Bonds in any other jurisdiction outside of Belgium.

The distribution of this Prospectus and the subscription for, and acquisition of, the Bonds may, under the laws of certain countries other than Belgium, be governed by specific regulations or legal and regulatory restrictions. Individuals in possession of this Prospectus, or considering the subscription for, or acquisition of, the Bonds, must inquire about those regulations and about possible restrictions resulting from them, and comply with those restrictions. Intermediaries cannot permit the subscription for, or acquisition of, the Bonds for clients whose addresses are in a country where such restrictions apply. No person receiving this Prospectus (including trustees and nominees) may distribute it in, or send it to, such countries, except in conformity with applicable law.

This Prospectus does not constitute an offer to sell or the solicitation of an offer to buy any securities other than the Bonds, or an offer to sell or the solicitation of an offer to buy the Bonds in any circumstances in which such offer or solicitation is unlawful. Neither the Issuer nor the Joint Lead Managers have authorised, nor do they authorise, the making of any offer of the Bonds (other than the Public Offer in Belgium) in circumstances in which an obligation arises for the Issuer or the Joint Lead Managers to publish a prospectus for such offer.

The following sections set out specific notices in relation to certain countries that, if stricter, shall prevail over the foregoing general notice.

### 13.2 *Selling restriction in the EEA*

In relation to each Member State of the European Economic Area which has implemented the Prospectus Directive (each a "**Relevant Member State**"), each Joint Lead Manager has represented and agreed that with effect from and including the date on which the Prospectus Directive is implemented in that Relevant Member State (the "**Relevant Implementation Date**") it has not made and will not make an offer of Bonds which are the subject of the offering contemplated by this Prospectus to the public in that Relevant Member State other than the offers contemplated in the Prospectus in Belgium from the time the Prospectus has been approved by the competent authority in Belgium and published in accordance with the Prospectus Directive, and **provided that** the Issuer has consented in writing to use of the Prospectus for any such offers, except that it may, with effect from and including the Relevant Implementation Date, make an offer of such Bonds to the public in that Relevant Member State:

- (a) to any legal entity which is a qualified investor as defined in the Prospectus Directive;
- (b) to fewer than 150 natural or legal persons (other than qualified investors as defined in the Prospectus Directive), subject to obtaining the prior consent of the relevant Joint Lead Manager or Joint Lead Managers nominated by the Issuer for any such offer; or
- (c) in any other circumstances falling within Article 3(2) of the Prospectus Directive,

**provided that** no such offer of Bonds shall require the Issuer or any Joint Lead Manager to publish a prospectus pursuant to Article 3 of the Prospectus Directive or supplement a prospectus pursuant to Article 16 of the Prospectus Directive.

For the purposes of this provision, the expression an "**offer of Bonds to the public**" in relation to any Bonds in any Relevant Member State means the communication in any form and by any means of sufficient information on the terms of the offer and the Bonds to be offered so as to enable an investor to decide to purchase or subscribe the Bonds, as the same may be varied in that Member State by any measure implementing the Prospectus Directive in that Member State and the expression "**Prospectus Directive**" means Directive 2003/71/EC (as amended, including by Directive 2010/73/EU), and includes any relevant implementing measure in the Relevant Member State.

### 13.3 *United Kingdom*

Each Joint Lead Manager has represented and agreed that:

- (a) it has only communicated or caused to be communicated and will only communicate or cause to be communicated an invitation or inducement to engage in investment activity (within the meaning of Section 21 of the Financial Services and Markets Act 2000) received by it in connection with the issue or sale of the Bonds in circumstances in which Section 21(1) of the Financial Services and Markets Act 2000 does not apply to the Issuer or the Guarantors; and
- (b) it has complied and will comply with all applicable provisions of the Financial Services and Markets Act 2000 with respect to anything done by it in relation to the Bonds in, from or otherwise involving the United Kingdom.

### 13.4 *United States*

The Bonds have not been and will not be registered under the Securities Act, and may not be offered or sold within the United States except in certain transactions exempt from the registration requirements of the Securities Act. Terms used in this paragraph have the meanings given to them by Regulation S under the Securities Act ("**Regulation S**").

Each Joint Lead Manager has agreed that:

- (a) none of it, its affiliates or any person acting on its or their behalf, has engaged or will engage in any directed selling efforts (within the meaning of Regulation S) with respect to the Bonds; and

- (b) it, its affiliates or any person acting on its or their behalf, has and will offer or sell or solicit offers for the Bonds as part of their initial distribution only in offshore transactions within the meaning and meeting the requirements of Rule 903 of Regulation S under the U.S. Securities Act.

Terms used in this paragraph have the meanings given to them by Regulation S.

The Bonds are being offered and sold outside of the United States in reliance on Regulation S.

In addition, until 40 days after the commencement of the Public Offer of the Bonds, an offer or sale of Bonds within the United States by a dealer that is not participating in the offering may violate the registration requirements of the Securities Act.

## PART XIV – GENERAL INFORMATION

1. Application has been made for the Bonds to be listed and admitted to trading as from the Issue Date on the regulated market of Euronext Brussels. Belfius Bank NV/SA has been appointed as listing agent for that purpose.
2. The approval by the FSMA does not imply any appraisal of the appropriateness or the merits of the issue of the Bonds, nor of the situation of the Issuer or any of the Guarantors.
3. Each of the Issuer and the Guarantors have obtained all necessary consents, approvals and authorisations in Belgium in connection with the issue of the Bonds and the provision of the Guarantees. The issue of the Bonds was authorised by resolutions passed by the board of directors of the Issuer on 22 February 2017. The provision of the Guarantee by the Guarantors was authorised by the board of directors of Gaselwest on 28 April 2017, by the board of directors of IMEA on 25 April 2017, by the board of directors of Imewo on 28 April 2017, by the board of directors of Intergem on 27 April 2017, by the board of directors of Iveka on 25 April 2017, by the board of directors of Iverlek on 24 April 2017 and by the board of directors of Sibelgas on 28 March 2017.
4. There has been no significant change in the financial or trading position of the Issuer since 31 December 2016 and no material adverse change in the Issuer's prospects since 31 December 2016. There has been no significant change in the financial or trading position of the Guarantors since 31 December 2016 and no material adverse change in the Guarantors' prospects since 31 December 2016.
5. Other than as disclosed in section 4 of "*Part IX – Description of the Issuer and the Guarantors*" of the Prospectus, neither the Issuer nor the Guarantors have been involved in any governmental, legal or arbitration proceedings (including any such proceedings which are pending or threatened of which the Issuer or Guarantors are aware) during the twelve months preceding the date of this Prospectus which may have or has had in the recent past significant effects on the financial position or profitability of the Issuer or the Guarantors.
6. The Bonds have been accepted for settlement through the NBB-SSS. The Common Code of the Bonds is 162910965. The International Securities Identification Number (ISIN) of the Bonds is BE0002285543. The address of the NBB-SSS is Boulevard de Berlaimont 14, 1000 Brussels, Belgium.
7. There are no material contracts entered into other than in the ordinary course of the Issuer's or Guarantors' business, which could result in any member of the Eandis Economic Group being under an obligation or entitlement that is material to the Issuer's or Guarantors' ability to meet their obligations to Bondholders in respect of the Bonds being issued.
8. Except as set out in the Prospectus, so far as the Issuer and the Guarantors are aware, no other person involved in the Public Offer has any interest, including conflicting ones, that is material to the Public Offer, save for the Joint Lead Managers in respect of any fees payable to them in connection with the Public Offer and their capacity as creditors of the Eandis Economic Group.
9. Where information in this Prospectus has been sourced from third parties, this information has been accurately reproduced and as far as the Issuer is aware and is able to ascertain from the information published by such third parties no facts have been omitted which would render the reproduced information inaccurate or misleading. The source of third party information is identified where used.
10. The Issuer does not intend to provide any post-issuance information in relation to the Bonds, save to the extent required by law.
11. Moody's Investor Service Ltd. has assigned a corporate rating A3 ('stable outlook') to the Issuer on 14 December 2016. On 14 December 2016, Moody's Investor Services Ltd. downgraded the Issuer's rating from A1 (negative outlook) to A3 (stable outlook). This was mainly because of Moody's anticipation that certain measures that were contemplated earlier to improve the Issuer's credit quality would not be implemented following the cancellation of the process for an entry of a private partner in the capital of the Guarantors and the corresponding capital increase. This



made a near-term strengthening of the Issuer's balance sheet unlikely from their perspective. In addition, the rating agency re-assessed the support assumptions embedded in the Issuer's long-term ratings. The rating has not been changed since then. Creditreform Rating AG has assigned a corporate rating A+ ('stable outlook') to the Issuer on 18 January 2017 for the first time. The rating has not been changed since then. The Bonds will not be rated by Moody's or any other rating agency.

12. During the Subscription Period and during the life of the Bonds, copies of the following documents will be available, during usual business hours on any weekday (Saturdays, Sundays and public holidays excepted), for inspection at the registered office of the Issuer, Brusselsesteenweg 199, 9090 Melle, Belgium, as well as on the Issuer's website ([www.eandis.be](http://www.eandis.be)):
- the Agency Agreement;
  - the Clearing Services Agreement;
  - the Guarantees;
  - the articles of association (*statuten/statuts*) of the Issuer and of the Guarantors, in Dutch;
  - the published annual reports and audited consolidated accounts of the Issuer for the financial years ended 31 December 2015 and 31 December 2016 and the published audited consolidated accounts of the Eandis Economic Group for the financial years ended 31 December 2015 and 31 December 2016;
  - a copy of this Prospectus together with any supplement to this Prospectus; and
  - all reports, letters and other documents, balance sheets, valuations and statements by any expert any part of which is extracted or referred to in this Prospectus.

This Prospectus will be published on the website of Euronext Brussels ([www.euronext.com](http://www.euronext.com)) and on the website of the FSMA ([www.fsma.be](http://www.fsma.be)).

13. Copies of the documents incorporated by reference in the Prospectus may be obtained (without charge) from the registered offices of the Issuer, the website of the Issuer ([www.eandis.be](http://www.eandis.be)) and the website of Euronext Brussels ([www.euronext.com](http://www.euronext.com)).
14. EY, having its registered office at De Kleetlaan 2, 1831 Diegem, represented by Mr P. Eelen (member of the *Instituut der Bedrijfsrevisoren/Institut des Réviseurs d'Entreprises*), has audited the consolidated financial statements of the Issuer as of and for the financial years ended 31 December 2015 and 31 December 2016 and the consolidated financial statements of the Eandis Economic Group as of and for the financial years ended 31 December 2015 and 31 December 2016.

**ANNEX 1**  
**INDEX OF DEFINED TERMS**

*[see overleaf]*

€	ii	euro	ii
A shares	93	Euroclear	i
Agency Agreement	38	Events of Default	46
Agent	38	ex ante	21
Aggregate Nominal Amount	137	ex post	21
Allocation Structure	139	exogenous	69
allowable income	21, 71	Ferrarimeter	74
Alternative Settlement System	39	Financial Intermediary	9, 33, 44
Assigned Bonds	139	First Electricity Directive	20
Atrias	77	First Gas Directive	20
Authorised Offeror	iv, 1, 135	Flemish Energy Contribution	112
Belfius	i, 135	Fluvius	77
Belgian Investor	132	Fluxys	60
Beneficial Owners	130	FSMA	i
beta factor	72	FTT	132
BNP Paribas Fortis	i, 135	Gas Law	68
Bondholder	11, 52	gearing	72
Bondholders	11, 39	GECs	109
Bonds	i, 38, 49, 52	Guarantee	39, 52
Business Day	41	Guaranteed Liabilities	8, 39
C certificates	93	Guarantees	i, 39
Calculation Agent	38	Guarantor	i, 39, 52
Change of Control	9, 43	Guarantors	i, 5, 39
Change of Control Notice	9, 45	holders of Bonds	39
Change of Control Put	33	IGA	133
Change of Control Put Date	10, 43	Indexis	77
Change of Control Put Exercise Notice	9, 44	Infrac	86
Change of Control Put Exercise Period	10, 43	interest	41, 129
Change of Control Put Redemption Amount	10, 43	Interest Amount	42
CHPCs	109	Interest Payment Date	42
Clearing Services Agreement	38, 51	Interest Period	42
Clearstream, Luxembourg	i	Intermediary	130
Code	85, 93	Investor Relations	135, 137, 140
Compensation	74	Investor's Currency	35
Condition	38	Issue Date	17, 42, 49, 135
Conditions	v, 38, 52	Issue Price	136
Confirmation Law	68	Issuer	i, 2, 38, 52, 77
cost-plus	67	Joint Lead Manager	i, 135
Day Count Fraction	41	Joint Lead Managers	i, 135
De Stroomlijn	77	kWh-tariffs	74
Directive	133	Listing Agent	38
DIS	25, 63, 89	Maturity Date	i, 43
Domiciliary Agent	38	Minimum Sales Period	138
Draft Directive	132	Minimum Subscription Period	19
DSOs	2, 55, 81	N Account	130
Eandis	77	natural monopoly	63
Eandis Economic Group	i, 2	NBB	i, 38, 129
Eandis System Operator	2	NBB-SSS	i, 38, 129
Electrabel	78	non-exogenous	71
Electricity Law	68	non-manageable costs	69
Eligible Investor	53	offer of Bonds to the public	142
Eligible Investors	129	Participant	129
endogenous	71	Participating Member States	133
Energy Decree	21	Paying Agent	38
Energy Efficiency Directive	107	Permitted Public Offer	iv
Energy Order	63	Permitted Successor Entity	48
EUR	ii	Placement Agreement	18, 52, 135
		principal	41

Proceedings .....	49	Second Gas Directive.....	20
Production or Supply Entities.....	63	Securities Act .....	v
Proportional Share .....	52	Securities Settlement System Regulations .....	38
Prospectus.....	i	Security Interest .....	41
Prospectus Directive .....	ii, 142	Specified Denomination.....	i, 39
Prospectus Law.....	i	State Grid .....	98
Prospectus Regulation .....	ii	Stock Exchange Tax Representative.....	132
Prosumers .....	74	Subscription Period.....	iv, 135
Public Entity .....	9, 43	Subsidiaries .....	77
Public Offer .....	i, 1, 135	Subsidiary .....	41
Put Exercise Receipt.....	9, 44	SYNDUCTIS .....	77
QI Fee .....	19	TARGET System.....	42
Qualified Investors .....	16, 32, 135	Tariff Decrees .....	68
Rate of Interest .....	42	Taxes .....	46
RECs.....	22, 109	Third Electricity Directive .....	21
Regulation S .....	142	Third Energy Package .....	21
Regulatory Assets or Liabilities or RALs.....	74	Third Gas Directive.....	21
Relevant Date .....	41	TM 2017-2020 .....	69
Relevant Debt .....	10, 40	transport company.....	61
Relevant Implementation Date .....	142	TSO .....	55, 81
Relevant Member State .....	iv, 142	unit .....	42
Responsible Persons .....	ii	VREG .....	67
Retail Fee.....	16, 19, 32	WACC .....	71
Retail Investors .....	16, 32, 135	Warmte@Vlaanderen.....	77
revenue cap-oriented .....	21	Winter Package .....	21
right of access .....	59	X Account .....	129
Second Electricity Directive .....	20		

**ANNEX 2**  
**CONSOLIDATED FINANCIAL STATEMENTS EANDIS ECONOMIC GROUP AS OF AND**  
**FOR THE FINANCIAL YEAR ENDED 31 DECEMBER 2016**



**Economic Group Eandis**

**Consolidated Financial Statements IFRS**

**Year end 31 December 2016**

## Content

### Consolidated Financial Statements

Consolidated statement of profit or loss  
Consolidated statement of comprehensive income  
Consolidated statement of financial position  
Consolidated statement of changes in equity  
Consolidated statement of cash flows

#### Notes to the consolidated financial statements

##### Basis of preparation

1. Reporting entity
2. Summary of significant accounting policies
  - 2.1. Statement of compliance and basis of presentation
  - 2.2. Principles of consolidation
  - 2.3. Significant accounting policies
  - 2.4. Summary of changes in accounting policies
  - 2.5. Use of estimates and judgments
  - 2.6. Standards issued but not yet effective

##### Segment information

3. Segment information

##### Performance of the year

4. Operating revenue
5. Cost of trade goods
6. Cost for services and other consumables
7. Employee benefit expenses
8. Amortization, depreciation, impairments and changes in provisions
9. Other operational expenses
10. Regulatory balances and transfers
11. Financial results
12. Income tax expenses

##### Assets

13. Intangible assets
14. Property, plant and equipment
15. Investments in other companies
16. Other investments
17. Long term receivables
18. Inventories
19. Trade and other receivables
20. Cash and cash equivalents

##### Liabilities

21. Equity
22. Interest bearing loans and borrowings
23. Pensions and other post-employment employment benefit plans
24. Derivative financial instruments
25. Provisions, other
26. Government grants
27. Trade payables and other liabilities
28. Current tax liabilities

**Financial instruments**

- 29. Financial instruments: risks and fair value

**Other information**

- 30. Related parties
- 31. Commitments and contingencies
- 32. Events after the reporting date
- 33. List of group entities included in the consolidation

**Operating in a regulated environment**

- 34. Operating in a regulated environment



# Consolidated Financial Statements

## Consolidated statement of profit or loss

(In thousands of EUR)	Notes	2016	2015
<b>Operating revenue</b>	<b>4</b>	<b>2.788.767</b>	<b>2.677.762</b>
Revenue		2.454.266	2.315.718
Other operating income		65.576	59.116
Own construction, capitalized		268.925	302.928
<b>Operating expenses</b>		<b>-2.169.960</b>	<b>-2.065.689</b>
Cost of trade goods	5	-1.039.602	-1.025.983
Cost for services and other consumables	6	-324.824	-488.053
Employee benefit expenses	7	-360.996	-368.472
Depreciation, amortization, impairments and changes in provisions	8	-325.901	-333.272
Other operational expenses	9	-46.881	-55.888
Regulated transfers	10	-71.756	205.979
<b>Result from operations</b>		<b>618.807</b>	<b>612.073</b>
Finance income	11	15.913	27.011
Finance costs	11	-205.922	-211.874
<b>Profit before tax</b>		<b>428.798</b>	<b>427.210</b>
<b>Income tax expenses</b>	<b>12</b>	<b>-145.906</b>	<b>-142.767</b>
<b>Profit for the period</b>		<b>282.892</b>	<b>284.443</b>

## Consolidated statement of comprehensive income

(In thousands of EUR)	Notes	2016	2015
<b>Profit for the period</b>		<b>282.892</b>	<b>284.443</b>
<b>Other comprehensive income</b>			
<b>Items not to be reclassified to profit or loss in subsequent periods</b>			
Actuarial gains (losses) on long term employee benefits	23	-5.311	51.003
Deferred tax gains (losses)	12	15.564	-2.929
<b>Net other comprehensive income not being reclassified to profit or loss in subsequent periods</b>		<b>10.253</b>	<b>48.074</b>
<b>Total comprehensive income for the period</b>		<b>293.145</b>	<b>332.518</b>

## Consolidated statement of financial position

(In thousands of EUR)	Notes	31 December 2016	31 December 2015
<b>Non-current assets</b>		<b>7.902.818</b>	<b>7.908.256</b>
Intangible assets	13	96.776	105.586
Property, plant and equipment	14	7.804.089	7.800.585
Investments in an associate	15	30	11
Other investments	16	832	919
Long term receivables	17	1.091	1.155
<b>Current assets</b>		<b>1.715.003</b>	<b>1.814.932</b>
Inventories	18	35.295	45.316
Trade and other receivables	19	1.677.000	1.765.960
Cash and cash equivalents	20	2.708	3.656
<b>TOTAL ASSETS</b>		<b>9.617.821</b>	<b>9.723.188</b>
<b>EQUITY</b>	<b>21</b>	<b>2.063.972</b>	<b>1.977.198</b>
<b>Total equity attributable to owners of the parent</b>		<b>2.063.879</b>	<b>1.976.119</b>
Capital		1.262.948	1.278.688
Reserves		811.641	759.548
Other components of equity		-641.178	-651.430
Retained earnings		630.468	589.313
<b>Non-controlling interest</b>		<b>93</b>	<b>1.079</b>
<b>LIABILITIES</b>		<b>7.553.849</b>	<b>7.745.990</b>
<b>Non-current liabilities</b>		<b>5.994.950</b>	<b>6.027.245</b>
Interest bearing loans and borrowings	22	5.244.409	5.197.393
Employee benefit liability	23	259.363	331.250
Derivative financial instruments	24	131.067	145.715
Provisions	25	14.936	18.027
Deferred tax liability	12	343.819	334.860
Government grants	26	1.356	0
<b>Current liabilities</b>		<b>1.558.899</b>	<b>1.718.745</b>
Interest bearing loans and borrowings	22	766.697	963.796
Trade payables and other current liabilities	27	589.936	647.471
Current tax liabilities	28	202.266	107.478
<b>TOTAL EQUITY AND LIABILITIES</b>		<b>9.617.821</b>	<b>9.723.188</b>

## Consolidated statement of changes in equity

(In thousands of EUR)	Share Capital	Reserves	Other comprehensive income	Retained earnings	Total equity attributable to equity holders	Non-controlling interest	Total
<b>Balance at 1 January 2015</b>	<b>2.056.752</b>	<b>679.802</b>	<b>-699.505</b>	<b>570.241</b>	<b>2.607.290</b>	<b>1.079</b>	<b>2.608.369</b>
Total comprehensive income for the period	0	0	48.075	284.443	<b>332.518</b>	0	<b>332.518</b>
Share capital decrease	-895.798	0	0	0	<b>-895.798</b>	0	<b>-895.798</b>
Share capital increase	117.734	0	0	0	<b>117.734</b>	0	<b>117.734</b>
Addition/decrease reserves	0	79.746	0	-79.746	<b>0</b>	0	<b>0</b>
Dividends paid	0	0	0	-185.625	<b>-185.625</b>	0	<b>-185.625</b>
<b>Balance at 31 December 2015</b>	<b>1.278.688</b>	<b>759.548</b>	<b>-651.430</b>	<b>589.313</b>	<b>1.976.119</b>	<b>1.079</b>	<b>1.977.198</b>
Total comprehensive income for the period	0	0	10.252	282.892	<b>293.144</b>	0	<b>293.144</b>
Share capital decrease	0	0	0	0	<b>0</b>	-986	<b>-986</b>
Repayment of equity	-15.740	-23.928	0	36	<b>-39.632</b>	0	<b>-39.632</b>
Addition/decrease reserves	0	76.021	0	-76.021	<b>0</b>	0	<b>0</b>
Dividends paid	0	0	0	-165.752	<b>-165.752</b>	0	<b>-165.752</b>
<b>Balance at 31 December 2016</b>	<b>1.262.948</b>	<b>811.641</b>	<b>-641.178</b>	<b>630.468</b>	<b>2.063.879</b>	<b>93</b>	<b>2.063.972</b>

The above information is disclosed in the notes 'Equity' and as regard to 'other comprehensive income' in the notes 'Income tax expenses' and 'Employee benefit liabilities'.

## Consolidated statement of cash flows

(In thousands of EUR)	Notes	2016	2015
Profit for the period		282.892	284.443
Amortization of intangible assets	8, 13	45.824	44.264
Depreciation on property, plant and equipment	8, 14	282.676	292.841
Change in provisions (Reversal -; Recognition +)	8, 25	-3.091	-2.450
Impairment current assets (Reversal -; Recognition +)	8	492	-1.383
Gains or losses on realization receivables		6.878	11.690
Net finance costs	11	204.657	208.989
Change in fair value of derivative financial instruments	11	-14.648	-24.125
Gains or losses on sale of property, plant and equipment		28.144	40.308
Movement in government grants	26	-1	0
Income tax expense	12	145.906	142.767
<b>Operating cash flow before change in working capital and provisions for employee benefits</b>		<b>979.729</b>	<b>997.344</b>
Change in inventories	18	10.021	-11.117
Change in trade and other receivables		83.143	486.697
Change in trade payables and other current liabilities		-54.092	80.447
Change in employee benefits		-77.198	-42.821
<b>Net operating cash flow</b>		<b>-38.126</b>	<b>513.206</b>
Interest paid		-206.959	-211.917
Interest received		711	2.306
Financial discount on debts		476	673
Income tax paid		-26.596	-19.002
<b>Net cash flow from operating activities</b>		<b>709.235</b>	<b>1.282.610</b>
Proceeds from sale of property, plant and equipment		21.240	3.091
Purchase of intangible assets	13	-37.014	-43.291
Purchase of property, plant and equipment	14	-335.565	-391.201
Acquisition of companies and other investments		-19	0
Proceeds from sale of other investments	16	167	387
Net investments in long term receivables		-135	9
<b>Net cash flow used in investing activities</b>		<b>-351.326</b>	<b>-431.005</b>
Proceeds from issue of shares	21	0	117.734
Repayment of share capital	21	-40.618	-895.798
Repayment of borrowings	22	-738.558	-516.126
Proceeds from borrowings	22	400.000	400.000
Change in current liabilities	22	186.071	225.238
Transfer of guarantee for allotments		0	-2.285
Dividends paid	21	-165.752	-185.625
<b>Net cash flow from/used in financing activities</b>		<b>-358.857</b>	<b>-856.862</b>
<b>Net increase/decrease in cash</b>	<b>20</b>	<b>-948</b>	<b>-5.257</b>
<b>Cash and cash equivalents at the beginning of period</b>		<b>3.656</b>	<b>8.913</b>
<b>Cash and cash equivalents - at end of period</b>		<b>2.708</b>	<b>3.656</b>

# Notes to the consolidated financial statements

## Basis of preparation

### 1. Reporting entity

The consolidated financial statements of the Economic Group Eandis comprise – beside the accounts of the 7 Flemish Distribution System Operators (DSOs) Gaselwest, IMEA, Imewo, Integem, Iveka, Iverlek and Sibelgas – the accounts of the subsidiaries being the operating company Eandis System Operator cvba, and its subsidiaries. The aggregated accounts taken together form the 'Economic Group'.

The DSOs are being managed centrally by their operating company Eandis System Operator.

The statutory aim of the DSOs is the distribution system operation as understood by the Flemish Energy Decree and their execution resolutions, as well as carrying out each peripheral activity, such as public lighting and generating electricity from cogeneration.

The main activities are subject to the regulation by the Flemish Regulator of Electricity and Gas (VREG). For more information, see chapter 'Operating in a regulated environment'.

The Group can also carry out other activities such as energy services to local authorities (ESLA). At the request of the local public authorities (municipalities, cities, ...) Eandis System Operator offers support at cost price aiming at planning and implementing efficient measures and projects for energy saving and energy efficiency.

The activity for the development, construction and operation of district heating grids and the delivery of heat was added to the portfolio of services.

The DSOs are mission charged associations according to the provisions of the Flemish Decree on Intermunicipal Cooperation (6 July 2001, 25 April 2014 and 13 May 2016).

All companies of the Group are registered in Belgium.

In October 2011, Eandis obtained an A1 rating (negative outlook) from the rating agency 'Moody's Investors Service Ltd.' (Moody's). On 14 December 2016 this rating was downgraded to A3 with a stable outlook as a result of the non-execution of the merger of the seven DSOs in Eandis Assets and the discontinuation of the process to attract a private partner for this merged company. Despite the downgrade, Eandis remains a solid issuer with a rating that aligns with the rating of many of its European peers. See also the press releases of Eandis dated 14 December 2016 and 3 October 2016 on [www.eandis.be](http://www.eandis.be).

On 18 January 2017, Eandis obtained a second rating. The German credit rating agency Creditreform Rating AG granted Eandis an A+ rating with stable outlook. See also press release on [www.eandis.be](http://www.eandis.be).

Eandis System Operator cvba operates in 229 cities and municipalities in the Flemish Region (Belgium) but also in 4 municipalities of the Walloon region. The Group employed on average 4.210 persons during 2016.

This financial report for the financial year ended 31 December 2016 has been established by the Management Committee on 13 March 2017 .

## 2. Summary of significant accounting policies

### 2.1. Statement of compliance and basis of presentation

The consolidated financial statements have been prepared in accordance with International Financial Reporting Standards (IFRS), as published by the International Accounting Standard Board (IASB) and endorsed by the European Union. The Group has not early adopted any new IFRS standard that is effective after 2016.

The consolidated financial statements were expressed in thousands of euro, which is the functional currency and presentation currency of the Group. They have been prepared with the assumption that business activities will be continued and under the historical cost convention method unless otherwise stated.

### 2.2 Principles of consolidation

The consolidated financial statements comprise all subsidiaries over which the Group has control. There is control when the Group has the power to govern the financial and operating policies of the entity so as to obtain benefits from its activities. Such a form of control exists when the companies, directly or indirectly, hold more than half of the voting rights in the entity. The existence and impact of potential voting rights that were exercisable or convertible at that time, are being taken into consideration when judging whether the Group has the control to determine the financial and operating policies of another entity.

Subsidiaries have been fully consolidated as of the date on which the Group gained actual control until the date the Group no longer exercises such control.

The financial reporting of the subsidiaries is prepared for the same reporting year as that of the parent companies, using consistent accounting principles. All intercompany transactions, balances and unrealized gains and losses between group companies have been eliminated.

Non-controlling interest in the net assets of the consolidated subsidiaries has been individually reported in equity of the parent companies. Non-controlling interest consists of the amount of that interest at the acquisition date and the non-controlling share in the equity changes since the date of the business combination. Losses relative to the minority that are higher than the non-controlling interests in the subsidiary's equity have been allocated to the Group's interests with the exception of those cases in which the minority has a binding obligation to make additional investments to compensate for the losses and is able to do so.

A list of the subsidiaries of the Group is set out in note 'List of group entities included in the consolidation'.

### 2.3 Significant accounting policies

The applied accounting policies are consistently applied with last year's accounting principles.

#### a) Operating income

##### *Goods sold and services rendered*

Revenue from sale of goods has been recognized when all of the following conditions have been satisfied: the Group transferred the significant risks and rewards of ownership of the goods to the buyer; the Group retains neither the continuing managerial involvement nor effective control over the goods sold; the amount of revenue can be determined reliably; it is probable that the

economic benefits associated with the transaction will flow to the Group; and costs incurred or to be incurred in respect of the transaction can be measured reliably.

On the basis of the previously mentioned principles the sale of goods and the rendering of services have been recognized at the moment of delivery of the goods to the customer, of the customer accepting the goods and of the collectability of the related amounts.

*Distribution network remuneration (energy transport) – Social function (energy supply)*

The distribution grid revenue (grid fee) is based on the actual billing of the grid fee of the DSOs in the relevant year.

The billing of grid fee to energy suppliers and other DSOs is based on the approved tariffs that are published on the websites of the respective DSOs. The real grid fee invoice contains invoiced advances (for customers whose meter is recorded annually), settlement billing (from annually recorded, manual monthly recorded and remotely read access points) as well as rectification invoices recorded in the calendar year concerned.

*Interest income* is recorded as soon as acquired and for the period to which it relates (taking into account the asset's actual interest rate), unless there is doubt about its collectability.

*Dividends received* are recognized in the income statement at the moment they are granted.

*Government grants* are recognized in the balance sheet as soon as it is reasonably certain that the grant will be received and that all of the conditions attached to it will be complied with.

Grants related to an asset are included in Government grants and will be recognized in the income statement on a systematic basis over the expected useful life of the related asset.

Grants related to expenses are presented in the income statement as Other operating income in the same period in which the costs are included.

## b) Expenses

*The finance costs* include interest on loans, calculated using the effective interest rate method and bank charges. All interest and other costs incurred in connection with loans or other financial transactions such as hedging options are recognized as financial expenses when they occur.

The *taxes on profit or loss* for the financial year include the current and deferred taxes. The tax on profit of the year is recorded in the profit and loss accounts unless they relate to transactions that were directly recorded in equity. In this case, the taxes are directly charged to equity.

The current tax expenses are the expected current taxes payable on the taxable income for the year, based on tax rates in effect at the balance sheet date and any adjustment to current taxes payable from previous years. For the calculation of the income tax on the taxable income for the year, the current tax rate (that has been enacted or substantively enacted by the end of the reporting period) is used.

Deferred taxes are recognized for temporary differences between the tax values of assets and liabilities and the carrying amounts for financial reporting purposes.

Until the end of 2014 the DSOs are only subject to legal entity tax on the portion of the dividend granted to the private partner/participant (Electrabel N.V.). As from 2015 onwards, the DSOs will have to pay corporate tax, as well as Eandis System Operator and its subsidiaries.

## c) Intangible assets

Intangible assets are measured at cost less any accumulated amortizations and possible impairment losses.



Costs relating to research, which is carried out with the purpose of obtaining new technical knowledge and insights, are recognized in the income statement in the period in which they occur.

Costs relating to the development phase, in which knowledge obtained through research is applied in order to achieve a plan or design for the production of new or significantly improved products and processes, are included in the balance sheet if and only if the product or process was technically and commercially feasible, the entity has the necessary resources to complete the development, it is probable that future economic benefits will flow into the Group and the cost can be measured reliably. The capitalised amount includes all costs that are directly attributable to the creation, production, and the preparation of the asset, so that it could operate in the same manner as intended by the management.

Until 2014, amortization is recognized in profit or loss on a straight-line basis as of the date of bringing the asset into use and over the estimated useful life of each component of an item of intangible assets.

As from 2015 the DSOs are subject to corporate income tax and the amortization is calculated, in accordance with the tax rules, on a pro rata temporis basis during the year in which the asset is brought into use. This means that amortization starts in the month after the month during which the asset is brought into use.

Another amortization method is only used if the expected pattern of consumption of the future economic benefits of the asset is better reflected.

Intangible assets are not revalued.

When the carrying amount of an intangible asset exceeds its recoverable amount, the asset is considered impaired and is written down to its recoverable amount.

The following amortization percentages are used in the calculation of depreciation:

Software	20,00 %
Cost for smart projects, clearing house and district heating	20,00 %

#### d) Property, plant and equipment

Property, plant and equipment are measured at historical cost less third party contributions, the accumulated depreciations and impairment losses. The historical cost comprises the initial purchase price plus other directly attributable costs.

The cost price of assets of own-production comprises the cost of material, direct labour cost and a reasonable part of indirect labour costs. These indirect labour costs comprise that part of general administrative and operational costs that cannot be directly attributed to investment expenses. These costs (for the largest part personnel costs) are added to the cost price of investment projects according to the internal billing system.

Each part of an item of property, plant and equipment with a cost that is significant in relation to the total cost of the item can be depreciated separately.

The Group recognizes the cost of an expansion or replacement part of such asset when these costs have been incurred if it is probable that the future economic benefits associated to that asset will flow to the Group and the asset's cost can be measured reliably. All other costs are expensed as incurred.

As from 2015 the costs of the networks not yet completed are classified as 'Assets under construction'. The investments reported are not depreciated.

Until 2014, depreciation is recognized in profit or loss on a straight-line basis as of the date of bringing into use and over the estimated useful life of each component of an item of property, plant and equipment.

As from 2015 the DSOs are subject to corporate income tax and the depreciation is calculated, in accordance with the tax rules, on a pro rata temporis basis during the year in which the asset is brought into use. This means that depreciation starts in the month after the month during which the asset is brought into use.

Land is not depreciated. The applied depreciation percentages on the basis of the average useful life are as follows.

Construction and administrative buildings *	2,00 %
Networks and lines	2,00 %
Other distribution installations	3,00 %
Service pipes for heating	3,00 %
Technical installations buildings*	4,00 %
Heat stations, cathodic protection (heating)	5,00 %
Issuing station (heating)	6,67 %
Recycled equipment	6,67 %
Optical fibre	10,00 %
Electronic metering equipment	10,00 %
Office furniture and tools	10,00 %
Leasehold improvements*	10,00 %
Leasehold improvements – rented buildings*	11,12 %
Vehicles	20,00 %
Electronics in administrative buildings	20,00 %
Hardware	33,33 %
Test equipment EVA (Electric vehicles in action)	50,00 %

\* The depreciation rates indicated with an asterisk were used from fiscal year 2014 for the newly acquired investments

In the opening balance sheet as per 1 January 2007 the Belgian GAAP carrying amount, as accepted by the CREG (Commissie voor de Regulering van de Elektriciteit en het Gas), was taken as the opening value for IFRS.

Repair and maintenance costs that do not increase the future economic benefits, are recognized in the income statement as incurred.

Recognition of costs in the carrying amount of an item of property, plant and equipment ceases when the asset is at its location and in the condition necessary for it to function in the manner intended by management.

#### *Gains and losses on sale*

Any gain or loss arising on a sale of property, plant and equipment is included in the income statement. They are recognized when the significant risks and rewards of ownership have been transferred to the buyer, collectability of the consideration is probable, the associated costs can be estimated reliably, and there is no continuing managerial involvement with the property, plant and equipment.

#### *Leasing*

Lease of assets under which all the risks and rewards incidental to ownership are substantially retained by the lessor, are classified as operating lease.

Lease payments based on operating leases are expensed on a straight-line basis, unless another systematic method is more representative of the time pattern of the benefits for the user.

#### *Impairment*

The Group assesses at each reporting date whether there is an indication that an asset may be impaired. If any indication exists, the Group estimates the asset's recoverable amount.

Impairment has been recognized if an asset's carrying amount exceeds the recoverable value. Impairment is charged directly to the income statement.

#### e) Investments

All investments are accounted for at trade date.

Investments in equity instruments consist of interests in entities in which the Group does not have significant influence or control. This is the case in companies where the Group has less than 20% of the voting rights. Such investments are designated as financial assets available for sale and are at initial recognition measured at fair value unless the fair value cannot be reliably determined in which case they are measured at cost.

An impairment is recognized if the carrying amount exceeds the expected realizable value.

#### f) Inventories

Inventories have been measured at purchase cost. Their value has been determined using the moving weighted average method.

An impairment is carried out on inventories if, due to their obsolescence, they are no longer usable or if their carrying amount exceeds the estimated sales price. If items of inventory have not been used for more than one year, an impairment of 100 % is recorded.

This impairment loss is recognized as an expense in the income statement.

#### g) Trade and other receivables

Trade and other receivables are measured at amortized cost.

An allowance for doubtful debt is recognized if the collection of the receivable becomes doubtful and after comparison with the realizable value.

In the case of a bankruptcy or judicial reorganization the receivable is immediately impaired and the value added tax recovered, on the basis of a certificate obtained from the curator or a publication of the closing of the bankruptcy in the annex to the Belgian Official Gazette.

In the framework of the full liberalization of the energy market in Flanders as per 1 July 2003, an impairment loss was recognized for the total amount including VAT of all receivables as per 31 December 2003, older than 6 months. These provisions have been reversed in view of the collection of these receivables or they have been used whenever these receivables have been written off.

The receivable of the work carried out and delivered services, with the exception of, on the one hand, the damages handled by the legal department and, on the other hand, the receivables from the affiliated municipalities, which are overdue for more than 6 months are recognized as doubtful and therefore impaired at 100% (excluding VAT).

A provision for bad debt related to receivables from energy supplies by the Distribution System Operators is calculated and recorded on the basis of the average collection degree stemming from statistical data of the payment history that was kept since the liberalisation of the energy market for the main client categories.

Receivables are permanently impaired (written off) using the provision for bad debts that was set up for this purpose as soon as certificates, provided by bailiffs, lawyers or debt collection agencies can demonstrate that there is no recoverability possible.

Also when it can be revealed that the revenue associated with a possible recovery does not compensate (i.e. not economically justifies) the costs for this recovery, the receivable is completely impaired using the provision which was set up for this purpose.

#### h) Cash and cash equivalents

Cash and cash equivalents comprise the readily available cash resources, deposits that can be immediately withdrawn and other short term, highly liquid investments (with a maximum maturity

of three months), that are readily convertible to known amounts of cash and which are subject to an insignificant risk of changes in value. They are stated at face value, which approximates their fair value. For the purpose of the cash flow statement, they are presented as cash and cash equivalents.

i) Share capital

Up to the beginning of 2015, the share capital is represented by certificates C, shares A, C, D without nominal value and F and the shares/certificates E” and E. Together with the shares/certificates C, they are entitled to a dividend.

The shares A, C, D and F had voting rights; the certificates C, the shares/certificates E” and E did not have voting rights.

The profit is paid proportionally to the shares A or C and the certificates C after setting up the necessary reserves and after paying the remuneration for the F shares and the shares/certificates E” and E according to the reimbursement rate stipulated in the articles of association.

During 2015 the shares F and the shares/certificates E” and E were converted to shares A.

The shares A and C are entitled to a dividend.

The shares A and C have voting rights, the certificates C have no voting rights. The shares D have voting rights, but have no representation in the share capital.

Dividends are recognized as a liability in the period in which they have been approved.

If there are components of the results that are the consequence of elements originating in the captive period (before 1 July 2003) and that would have affected the outcome of the relevant period, then this part of the result is assigned to the participants according to the terms as were applicable with respect to the distribution of net profit realized in the years preceding the first effects of liberalization.

j) Loans and borrowings

Interest bearing loans are recognized initially at fair value less related transaction costs. Subsequent to initial recognition, interest bearing loans are measured at amortized cost, in which any difference between the proceeds and the reimbursement is charged to the income statement using the effective interest method over the maturity of the loans.

k) Employee benefit liability

*Pension plans and other post-employment benefits*

The contributions for defined contribution plans have been recognized as an expense at the moment when incurred.

Up to 2015 these kinds of pension plans were valued by using the intrinsic value and any individual difference between the mathematical reserve and the minimum guaranteed amount was recorded as a liability in the financial statements.

The law was amended on 18 December 2015 and from 1 January 2016 the guaranteed yield was changed to a variable yield (see note 'Pensions and other post-employment benefit plans'). Hence, the provision for defined contribution pension plans is valued as from 2016 according to the 'Projected Unit Credit'-method (PUC) without projection of the future premiums. The amount recognized in the balance sheet is the difference between this provision and the fair value of plan assets.

The Group's liabilities for the defined benefit plans, as well as for the subsequent costs, have been valued on the basis of the 'Projected Unit Credit' method. The amount recognized in the balance sheet represents the present value of the pension liabilities (Defined Benefit Obligation) mentioned, less the fair value of plan assets.

Remeasurements comprise actuarial gains and losses, and the return on plan assets (excluding interest) which is reflected in the statement of financial position with a charge or credit recognized in other comprehensive income in the period in which they occur.

Past service costs are recognized in profit or loss in the period of a plan amendment.

Net interest is calculated by applying the discount rate at the beginning of the period to the net defined benefit liability.

The amounts recognized in the income statement comprise service costs (including current service costs, past service costs, gains and losses on other long-term employee benefits as well as curtailments and settlements), net interest expense or income and remeasurement.

The Group presents the first two components of the defined benefit costs in profit or loss on the line item 'Employee benefit expenses' and 'Other financial results'.

*Other long-term employee benefits contain provisions for retirement and jubilee bonuses.*

These benefits are treated in the same manner as pension plans; however, past service costs and actuarial gains and losses have immediately been recognized in the income statement.

All pension liabilities are annually valued by a qualified actuary.

#### l) Derivative financial instruments

The Group uses derivative financial instruments (Linear Constant Maturity Swap – LCMS; Interest Rate Swaps - IRS and other) to hedge the exposure to interest rate risks that arise from its financing activities. Derivative financial instruments are initially recognized at fair value. The gain or loss resulting from fluctuations in the fair value is immediately accounted for through the income statement. The fair value of the interest rate swaps was the estimated amount the Group would receive or pay to end the swap at the balance sheet date, taking into account the actual interest rate and the creditworthiness of the counterparty.

The derivatives do not qualify for hedge accounting.

#### m) Provisions, other

Provisions are recognized in the balance sheet when the Group has a present (legal or constructive) obligation as a result of a past event, and when it is probable that an outflow of financial resources will be required to settle the obligation and the obligation's amount can be reliably estimated.

The amount recognized as provision is the best available estimate on the balance sheet date for the expenses needed to meet the existing liabilities, possibly discounted if the money's time value is relevant.

#### n) Trade and other liabilities

Trade and other liabilities have been measured at amortized cost.

#### o) Income tax expense

Current tax assets and liabilities are offset only if the entity has a legally enforceable right to set off the recognized amounts and has the intention to either settle the obligation on a net basis, or to realize the asset and settle the liability simultaneously.

The deferred tax assets and liabilities reflect the deductible or taxable temporary differences between the carrying amounts and the tax values.

The deferred tax assets and liabilities are measured at the tax rates that are expected to be applied in the period in which the claim will be realized or the obligation will be met, using the tax rates that have been enacted or substantively enacted by the end of the reporting period.

The deferred tax assets are recorded when it is probable that taxable profits will be realized to settle the deferred tax.

## 2.4 Summary of the new accounting standards applicable as from 2016

The following standards and interpretations are applicable for the accounting period beginning on 1 January 2016. Although these new standards and amendments are applied for the first time in 2016, they did not have a material impact on the annual consolidated financial statements of the Group.

As required, these standards and changes are detailed below.

- Amendments to IFRS 10, IFRS 12 and IAS 28 – *Investment Entities*: Applying the Consolidation Exception, effective 1 January 2016
- Amendments to IFRS 11 *Joint Arrangements* – Accounting for Acquisitions of Interests in Joint Operations, effective 1 January 2016
- Amendments to IAS 1 *Presentation of Financial Statements* – Disclosure Initiative, effective 1 January 2016
- Amendments to IAS 16 *Property, Plant and Equipment* and IAS 38 *Intangible Assets* – Clarification of Acceptable Methods of Depreciation and Amortisation, effective 1 January 2016
- Amendments to IAS 16 *Property, Plant and Equipment* and IAS 41 *Agriculture* – Bearer Plants, effective 1 January 2016
- Amendments to IAS 19 *Employee Benefits* – Defined Benefit Plans: Employee Contributions, effective 1 February 2015
- Amendments to IAS 27 *Separate Financial Statements* – Equity Method in Separate Financial Statements, effective 1 January 2016
- Annual Improvements to IFRSs 2010-2012 Cycle (issued December 2013), effective 1 February 2015
- Annual Improvements to IFRSs 2012-2014 Cycle (issued September 2014), effective 1 January 2016

## 2.5 Use of estimates and judgments

The preparation of the consolidated financial statements in conformity with IFRS requires management to make judgments, estimates and assumptions that might affect the reported amounts of assets and liabilities, and the amounts of revenue and expenses. The estimates and the underlying assumptions have been based on past experience and several other factors that are believed to be reasonable given the circumstances. The results thereof form the basis for the judgment on the carrying amount of assets and liabilities that could not be deduced in a simple way from other sources. The actual results could differ from these estimates.

The estimates and underlying assumptions are reviewed on an ongoing basis. Revisions to accounting estimates are recognized in the period in which the estimate is revised if the revision affects only that period or in the period of the revision and the future periods if the revision affects both current and future periods.

### *Defined benefit plans and other long term employee benefits*

The cost of the defined benefit pension plans and other long term employee benefits and the present value of the pension obligation are determined using actuarial valuations. This involves making various assumptions that may differ from actual developments in the future.

Due to the complexity of the actuarial calculations and the long-term nature of the obligation, the defined benefit obligation is highly sensitive to changes in the assumptions.

The major assumptions and a sensitivity analysis are disclosed in the note 'Pensions and other post-employment benefit plans'.

#### *Derivative financial instruments*

Information about major items of uncertainty and critical judgment with regard to the recording of the derivative financial instruments is included in the note 'Financial instruments: risks and fair value'.

## **2.6 Standards issued but not yet effective**

The following standards and interpretations were published, but were not yet applicable for the annual period beginning on 1 January 2016.

The standards and interpretations that are issued, but not yet effective, up to the date of issuance of the Group's financial statements are disclosed below. The Group intends to adopt these standards and interpretations, if applicable, when they become effective.

- IFRS 9 *Financial Instruments*, effective 1 January 2018  
This standard was issued in the framework of a wider project to replace IAS 39 *Financial Instruments: Recognition and Measurement*. IFRS 9 brings together all three aspects of the accounting for financial instruments project: classification and measurement, impairment and hedge accounting. IFRS 9 is effective for annual periods beginning on or after 1 January 2018, with early application permitted. Except for hedge accounting, retrospective application is required but providing comparative information is not compulsory. For hedge accounting, the requirements are generally applied prospectively, with some limited exceptions.
- IFRS 15 *Revenue from Contracts with Customers*, including amendments to IFRS 15: *Effective date of IFRS 15 and Clarifications to IFRS 15* (the Clarification to IFRS 15 is not yet endorsed by the EU), effective 1 January 2018  
IFRS 15 establishes a five-step model to account for revenue arising from contracts with customers. Under IFRS 15, revenue is recognized at an amount that reflects the consideration to which an entity expects to be entitled in exchange for transferring goods or services to a customer. The new revenue standard will supersede all current revenue recognition requirements under IFRS.  
The Group has not yet made a definitive choice on the application methodology and is currently assessing the possible impact on its financial statements resulting from the application of IFRS 15. At the moment the impact cannot reasonably be calculated. Further qualitative disclosures will be included in the 2017 reporting.
- Amendments to IFRS 2 *Share-based Payment* - Classification and Measurement of Share-based Payment Transactions, effective 1 January 2018
- Amendments to IFRS 4 *Insurance Contracts* – Applying IFRS 9 *Financial instruments* with IFRS 4, effective 1 January 2018
- IFRS 16 *Lease*, effective 1 January 2019  
IFRS 16 sets out the principles for the recognition, measurement, presentation and disclosure of leases and requires lessees to account for all leases under a single on-balance sheet model similar to the accounting for finance leases under IAS 17 *Leases*. The standard includes two recognition exemptions for lessees – leases of 'low-value' assets (e.g. personal computers) and short-term leases (i.e. leases with a lease term of 12 months or less). At the commencement date of a lease, a lessee will recognize a liability to make lease payments (i.e. the lease liability) and an asset representing the right to use the underlying asset during the lease term (i.e. the right-of-use asset). Lessees will be required to separately recognize

the interest expense on the lease liability and the depreciation expense on the right-of-use asset.

Lessees will also be required to remeasure the lease liability upon the occurrence of certain events (e.g., a change in the lease term, a change in future lease payments resulting from a change in an index or rate used to determine those payments). The lessee will generally recognize the amount of the remeasurement of the lease liability as an adjustment to the right-of-use asset.

- Amendments to IAS 7 *Statement of Cash Flows* – Disclosure Initiative, effective 1 January 2017
- Amendments to IAS 12 *Income Taxes* – Recognition of Deferred Tax Assets for Unrealized Losses, effective 1 January 2017
- Amendments to IAS 40 *Investment Property* – Transfers of Investment Property, effective 1 January 2018
- IFRIC 22 *Foreign Currency Transactions and Advance Consideration*, effective 1 January 2018
- Annual Improvements to IFRSs 2014-2016 Cycle (issued December 2016), effective 1 January 2017 and 1 January 2018

The Group will apply the new standards and interpretations applicable to its financial statements as soon as they become effective. The Group has not opted for early application of these standards and interpretations.

The adoption of these standards, interpretations and amendments to the standards already issued and their impact on the Group's results are currently being assessed.



## Segment information

### 3. Segment information

The Management Committee, responsible for the day-to-day management and the operational functioning of Eandis System Operator (ESO), its subsidiaries and the seven Flemish Distribution System Operators, reviews the financial data on the basis of a reporting in accordance with Belgian accounting standards.

This reporting is presented for the DSOs per energy component electricity and gas, as this is the best reflection of the nature and the financial profile of the activities. This segmentation also reflects the framework within which should be reported to the regulator VREG and also forms the basis for the calculation of the distribution network tariffs for the electricity and gas activities. As a result, they are distinguished from each other and each has its own cost drivers, specificities and risks. The DSOs also report a segment 'Other' in which the non-regulated activities are included such as the activities which took place before the liberalisation of the energy market (2003); the activities for the energy services for local authorities (ESLA), the district heating activity and other smaller activities.

The seven DSOs are organized by region and each applies separate network tariffs. The information per legal entity can be consulted, for the individual financial statements of the DSOs, at the Central Balance Sheet Office of the National Bank of Belgium.

The activities of the operating company Eandis System Operator and its subsidiaries are reported separately and on a consolidated basis. However, no segmentation per energy component is reported. All costs of these companies are recharged at cost price to mainly the seven DSOs where a breakdown by activity is performed based on an allocation system. Therefore the financial results of the operating companies (ESO group) are always 'null'.

In accordance with IFRS8, the Group reported at 31 December 2016 the following financial segmented information on the basis of the Belgian GAAP.

#### Statement of profit or loss

(In thousands of EUR) - Belgian GAAP	Electricity	Gas	Other	Eandis System Operator, consolidated	Aggregated total
Turnover	1.907.275	450.033	45.002	1.053.040	3.455.350
Other income	69.099	26.823	-19.055	94.165	171.031
Operating costs	1.640.625	284.085	27.470	1.133.535	3.085.716
<b>Operating profit (loss)</b>	<b>335.748</b>	<b>192.771</b>	<b>-1.523</b>	<b>13.670</b>	<b>540.666</b>
Financial income	599	148	123	109.107	109.977
Financial costs	131.033	64.412	-13	113.584	309.016
<b>Profit (loss) of the period before taxes</b>	<b>205.314</b>	<b>128.506</b>	<b>-1.387</b>	<b>9.193</b>	<b>341.627</b>
Income taxes	70.074	42.812	-695	9.193	121.384
<b>Profit for the period</b>	<b>135.240</b>	<b>85.694</b>	<b>-692</b>	<b>0</b>	<b>220.243</b>

## Statement of financial position

(In thousands of EUR) - Belgian GAAP	Electricity	Gas	Other	Eandis System Operator, consolidated	Aggregated total
Tangible fixed assets	4.789.201	3.100.640	7.941	3.083	7.900.865
Financial fixed assets	642	365	0	1.252	2.259
<b>FIXED ASSETS</b>	<b>4.789.843</b>	<b>3.101.005</b>	<b>7.941</b>	<b>4.336</b>	<b>7.903.124</b>
Amounts receivable after more than one year	0	0	700	3.270.500	3.271.200
Stocks and contracts in progress	40.672	258	8.217	35.295	84.442
Amounts receivable within one year	860.020	64.222	12.316	737.261	1.673.819
Cash at bank and in hand	46	0	0	9.405	9.451
Deferred charges and accrued income	891.050	131.052	5	295.592	1.317.699
<b>CURRENT ASSETS</b>	<b>1.791.787</b>	<b>195.532</b>	<b>21.238</b>	<b>4.348.053</b>	<b>6.356.611</b>
<b>Total Assets</b>	<b>6.581.630</b>	<b>3.296.537</b>	<b>29.179</b>	<b>4.352.389</b>	<b>14.259.735</b>
Capital	770.323	492.625	0	915	1.263.863
Equity premium	0	0	0	68	68
Revaluation surplus	481.630	303.482	0	0	785.112
Reserves	480.772	309.911	20.958	4	811.644
Retained earnings and profit of the period	22.950	11.137	33.848	20	67.955
Government grants	0	0	895	0	895
<b>EQUITY</b>	<b>1.755.674</b>	<b>1.117.156</b>	<b>55.701</b>	<b>1.007</b>	<b>2.929.538</b>
<b>MINORITY INTEREST</b>	<b>0</b>	<b>0</b>	<b>0</b>	<b>93</b>	<b>93</b>
<b>PROVISIONS FOR LIABILITIES AND CHARGES</b>	<b>5.633</b>	<b>12.035</b>	<b>461</b>	<b>259.363</b>	<b>277.491</b>
Amounts payable after more than one year	3.582.470	1.685.287	0	3.247.152	8.514.909
Amounts payable within one year	1.002.233	322.446	-32.274	799.473	2.091.878
Accrued charges and deferred income	235.620	159.613	5.292	45.302	445.826
<b>AMOUNTS PAYABLE</b>	<b>4.820.323</b>	<b>2.167.346</b>	<b>-26.983</b>	<b>4.091.926</b>	<b>11.052.613</b>
<b>Total Liabilities</b>	<b>6.581.630</b>	<b>3.296.537</b>	<b>29.179</b>	<b>4.352.389</b>	<b>14.259.735</b>

The reconciliation of the financial data mentioned above based on Belgian GAAP to IFRS

(In thousands of EUR) - Belgian GAAP	Aggregated total	IFRS	Difference
Turnover	3.455.350	2.454.266	1.001.084
Profit (loss) of the period before taxes	341.627	428.798	-87.171
Total assets	14.259.735	9.617.821	4.641.914
Total liabilities	14.259.735	9.617.821	4.641.914
Equity	2.929.538	2.063.972	-865.566

These differences can be explained as the result of:

- The elimination of all the transactions and balances between the members of the Economic Group Eandis as a result of the consolidation
- Reclassifications and adjustments/netting off
- The employee benefit liability is processed in the IFRS result
- The BE-GAAP deferred pension capitals is fully included in IFRS
- Adjustments for the provisions that do not meet the IFRS criteria are included, as well as adaptations to existing provisions
- The derivative financial instruments are recorded at fair value and an adjustment is recorded for the accrued interest
- Deferred taxes are recorded.

The two largest customers for the segment electricity together represent 60% of the turnover and the three largest customers of the segment for gas together represent 63% of the turnover.

## Performance of the year

### 4. Operating revenue

#### Revenue

(In thousands of EUR)	2016	2015
Distribution and transport grid revenue	2.319.115	2.182.494
Sale of energy	74.175	72.579
Construction works for third parties	60.976	60.645
<b>Total</b>	<b>2.454.266</b>	<b>2.315.718</b>

The Group has realized most of its revenue from the remuneration of the distribution and transport of electricity and gas via its networks. This revenue should be evaluated together with the regulatory transfers. The increase in distribution and transmission grid fee is due to the new tariff methodology of the VREG, which was applied as from 1 January 2015 and the additional adjustments to these tariffs during the year (see chapter 'Working in a regulated environment').

The sale of energy consists of the energy supplies to individuals who do not find an energy supplier on the market due to payment problems.

Sale of energy is mainly the delivery of energy to persons who experience payment difficulties and to whom commercial suppliers in the market do not supply energy.

The billing of construction works for third parties comprises the construction works carried out by Eandis System Operator (possibly in synergy with other utilities) for the account of customers.

#### Other operating income

(In thousands of EUR)	2016	2015
Recuperations	41.648	44.170
Other	23.928	14.946
<b>Other operating income</b>	<b>65.576</b>	<b>59.116</b>
<b>Own construction, capitalized</b>	<b>268.925</b>	<b>302.928</b>

The recuperations relate to billings for work performed for customers, the re-invoicing of costs for RUE campaigns and the recovery of general expenses by contractors, insurance and other authorities.

The other operating income mainly comprises allowances for damages and operations, gains on trade receivables (196 k EUR in 2016 and 207 k EUR in 2015) and gains on the sale of property, plant and equipment (9.948 k EUR in 2016 and 2.189 k EUR in 2015).

All costs related to distribution activities have been registered as operational costs. Periodically, a settlement has been recorded and certain costs related to investments have been activated through the item Own construction, capitalized. As a result, this revenue cannot be considered as an operating income.

This item also contains the contributions received from customers (97.618 k EUR for 2016 and 103.275 k EUR for 2015) which are also deducted as own construction, capitalized (-97.618 k EUR for 2016 and -103.275 k EUR for 2015).

## 5. Cost of trade goods

(In thousands of EUR)	2016	2015
Cost for transportation	475.044	455.715
Purchase of energy	30.316	30.030
Purchase of goods for resale	88.842	79.785
Purchase of grid losses	20.212	16.859
Certificates for green energy	425.188	443.594
<b>Total</b>	<b>1.039.602</b>	<b>1.025.983</b>

Apart from the transmission cost of electricity invoiced by the Transmission System Operator (TSO – Elia) the cost for transportation contains the costs of the federal contribution for an amount of € 71,067 million in 2016 and € 61,2 million in 2015. This contribution is used to finance certain public service obligations, the obligations for denuclearization, the reduction of emissions of greenhouse gases (Kyoto) and the costs relating to the regulation and control of the energy market. The DSOs recharge these costs in their tariffs to the end users, through the suppliers i.e. in a cascade mechanism (see note ‘Operating revenue’).

The Group has the obligation to buy certificates for green energy that were offered by producers of renewable energy at a certain price. These certificates can be sold by the DSOs in an active market. The value of the certificates sold is lower than the purchase price. The resulting costs were included under the heading ‘Certificates for green energy’ but also the revaluation cost to the fair value and the solidarity contribution on the certificates for green energy (see note ‘Trade and other receivables’).

## 6. Cost for services and other consumables

(In thousands of EUR)	2016	2015
Cost of purchase network grids	72.629	71.120
Cost for direct purchases	28.727	30.113
Fee for usage of installations	49.780	45.117
Advertising, information, documentation, receptions a.o.	7.724	9.320
Subsidy for rational use of energy (RUE)	72.595	72.820
Contribution 100 kWh free of charge	-3.340	150.214
Contracts and administration costs	8.121	1.582
Consultancy and other services	42.373	56.394
Other	46.215	51.373
<b>Total</b>	<b>324.824</b>	<b>488.053</b>

The cost for services and other consumables decreased with 163.229 k EUR compared to 2015.

This decrease is mainly due the contribution for 100 kWh free of charge (- 153.554 k EUR). This measure for free electricity was abolished from 1 January 2016. All related costs to this measurement were included in 2015 and in 2016 the settlement with the energy suppliers was recorded (see note 'Working in a regulated environment').

The item 'Other' comprises the costs for rent, communication, transport, insurance and other.

## 7. Employee benefit expenses

(In thousands of EUR)	2016	2015
Remunerations	257.575	258.746
Social security contributions	70.644	71.752
Contributions to defined benefit plans and other insurances	14.850	21.666
Other personnel costs	17.927	16.308
<b>Total</b>	<b>360.996</b>	<b>368.472</b>

The employee benefit expenses amounted to 360.996 k EUR in 2016, a decrease of 7.476 k EUR compared to 2015, mainly as a result of the decrease in the contribution for pension plans and insurances.

The average number of employees amounted to 4.210 persons in 2016 and 4.480 persons in 2015.

## 8. Amortization, depreciation, impairments and changes in provisions

(In thousands of EUR)	2016	2015
Amortization of intangible assets	45.824	44.264
Depreciation of property, plant and equipment	282.676	292.841
<b>Total amortization and depreciation</b>	<b>328.500</b>	<b>337.105</b>
Impairment of inventories and trade receivables	492	-1.383
Changes in provisions	-3.091	-2.450
<b>Total</b>	<b>325.901</b>	<b>333.272</b>

The amortization and depreciation amount to 328.500 k EUR at the end of 2016, a decrease of 8.605 k EUR in comparison to 2015. This decrease is mainly a result of the increase of assets, recorded as in construction, on which no depreciation is calculated.

From 2015 onwards, the calculation of the provision for doubtful debts takes into account the principles of the Belgian fiscal rules and hence it is based on statistical data obtained from the payment pattern of this category of clients (social suppliers) as from the liberalisation of the energy market.

The change in provisions mainly concerns the provision for restoration costs which amounted to 2.752 k EUR in 2016 and 2.192 k EUR in 2015 (see note 'Provisions, other'). The decrease of the provisions was due to the use (restoration and sale of land) and more specific elements which could reduce the provision of the restoration cost.

## 9. Other operational expenses

(In thousands of EUR)	2016	2015
Loss on disposal/retirement of property, plant and equipment	38.092	42.506
Loss on realization receivables	7.078	11.897
Other	1.711	1.485
<b>Total</b>	<b>46.881</b>	<b>55.888</b>

## 10. Regulated balances and transfers

Since 2011 the Group reports the additions, recoveries and regularisation for transfers in this separate section as 'Operating expenses', where previously they were reported as 'Revenue'. The Group believes that the balance between actual income and expenses and the budgeted income and expenses is not part of revenue, since the recovery through tariffs will occur in a subsequent period.

The regulated balances and transfers for 2016 and 2015 are as follows:

(In thousands of EUR)	2016	2015
Recuperation regulated transfers	134.602	53.726
Addition regulated balances	-62.846	-259.705
<b>Total</b>	<b>71.756</b>	<b>-205.979</b>

The revenue of the items 'Addition and recuperation transfers' relate to the additional revenue registration that is allowed as the difference between the actual income and expenses and the budgeted income and expenses as approved by the regulator. The result thus additionally reported will be recuperated through the tariffs of the following years (see note 'Operating in a regulated environment').

The additions of 2016 concern the regulatory balances and consist of 27.058 k EUR exogenous expenses that can be incorporated in the future tariffs, and 35.478 k EUR non-exogenous costs (volume differences) and the federal contribution payable amounting to 7.174 k EUR as well as the balances for the Walloon municipalities (under the supervision of the Walloon regulator CWAPE). The additions of 2015 relate to the regulatory transfers and consist of 218.001 k EUR exogenous expenses that may be charged to future tariffs and 41.704 k EUR non-exogenous costs (volume differences).



## 11. Financial results

(In thousands of EUR)	2016	2015
Interest income, banks	2	104
Interest income, derivative financial instruments	14.648	24.125
Other financial income	1.263	2.782
<b>Finance income</b>	<b>15.913</b>	<b>27.011</b>
Interest expenses, non-current loans	-192.876	-200.922
Interest expenses, current loans and other borrowings	-4.596	-2.362
Other financial expenses	-8.450	-8.590
<b>Finance costs</b>	<b>-205.922</b>	<b>-211.874</b>

Financial income decreases with 11.098 k EUR due to the fair value adjustment of the derivative financial instruments.

The other financial income contains mainly interest received as the capital cost allowance for the unsold stock of green energy certificates, financial discounts received and income from the sale of 'other investments'.

The interest expenses on non-current and current loans and borrowings decrease with 5.812 k EUR in comparison to 2015 as a result of lower interest rates on the financial markets resulting in refinancing at lower interest rates.

The other financial expenses amount to 8.514 k EUR and contain the interest cost on the defined benefit pension plans incurred issuance costs for loans and various bank costs.

## 12. Income taxes

(In thousands of EUR)	2016	2015
Current income tax expenses	-124.271	-122.605
Current income tax expenses on previous year result	2.888	-15
Tax increases	0	-739
Deferred income tax benefits (+)/expenses	-24.523	-19.408
<b>Total tax expenses</b>	<b>-145.906</b>	<b>-142.767</b>

### Current income tax expense on the result

Based on the Programme Act of 19 December 2014, the DSOs are subject to the corporate income tax of 33,99 % as from accounting year 2015.

(In thousands of EUR)	2016	2015
Profit before tax	341.627	336.708
Theoretical tax rate (1)	-116.119	-114.447
Effect non deductible expenses	-13.628	-19.871
Effect deductible expenses	5.476	11.713
<b>Total income tax expenses</b>	<b>-124.271</b>	<b>-122.605</b>

(1) Subject to the legal Belgian tax rate of 33,99 %

### Deferred taxes

Since the aforementioned law was ratified in 2014, deferred taxes for temporary differences were calculated between the tax values of assets and liabilities and the carrying amounts for financial reporting purposes, in accordance with the application of IAS12 income tax.

During 2016 a ruling for the DSOs was requested from the Federal Public Service Finance to obtain its decision on the correct fiscal treatment of, amongst others, the revaluation of fixed assets, the notional interest deduction and the impairment losses of trade receivables.

Concerning the impairment losses of trade receivables, the deduction of the recorded provision for doubtful debts as at 31 December 2014 as deductible costs in the income tax declaration of the tax years 2016 up to 2019 was requested. It is based on the principle, as defined in the aforementioned Programme Act and amended on 10 August, 2015, article 92, 4° that the provision for impairment losses, that are recorded during the period the company was subject to legal entity tax, is deductible as a professional cost to the extent that the conditions laid down in article 49 of the Code of the Income Tax of 1992 are fulfilled.

The total amount of impairment amounted to 77.109 k EUR at 31 December 2014 and was processed for the first time at 25,00 % in the tax assessment of the year 2016.

The ruling will be applicable until the year 2020.

The deferred taxes are a result of the following items and trigger the following movements on the balance sheet, the income statement and equity:

(In thousands of EUR)	2016	2015
Property, plant & equipment	-544.292	-558.704
Derivative financial instruments	44.384	49.364
Employee benefit liabilities	140.545	170.692
Provisions, restoration	986	1.617
Provisions, other	1.914	2.171
Impairment on trade receivables	13.105	0
Government grants	-461	0
<b>Net deferred tax asset/(liability)</b>	<b>-343.819</b>	<b>-334.860</b>

	2016	2016	2015	2015
(In thousands of EUR)	Movements via P&L	Movements via OCI	Movements via P&L	Movements via OCI
Property, plant & equipment	0	14.412	0	13.753
Derivative financial instruments	-4.980	0	-8.215	0
Employee benefit liabilities	-31.299	1.152	-15.515	-16.682
Provisions, restoration	-631	0	-159	0
Provisions, other	-257	0	4.482	0
Impairment on trade receivables	13.105	0	0	0
Government grants	-461	0	0	0
<b>Deferred tax benefit/(expense)</b>	<b>-24.523</b>	<b>15.564</b>	<b>-19.408</b>	<b>-2.929</b>
<b>Net movement during the year</b>	<b>-8.959</b>		<b>-22.337</b>	

The main temporary differences relate to the revaluation of property, plant & equipment and the provisions for pensions and other post-employment benefits. A deferred tax liability was recorded of 544.292 k EUR (558.704 k EUR in 2015) related to the revaluation of property, plant & equipment since, according to the Belgian tax law, the costs are not deductible. Concerning the pension and other post-employment benefit provision, the costs will be deductible according to the Belgian tax law, and therefore a deferred tax asset was recorded of 140.515 k EUR (170.692 k EUR in 2015).

(In thousands of EUR)	2016	2015
Deferred tax asset	200.934	223.844
Deferred tax liability	-544.753	-558.704
<b>Deferred tax liability, net</b>	<b>-343.819</b>	<b>-334.860</b>

The movements in the item deferred tax liability are as follows:

(In thousands of EUR)	2016	2015
<b>Total at 1 January</b>	<b>-334.860</b>	<b>-312.523</b>
Tax income/(expense) recognized in profit or loss	-24.523	-19.408
Tax income/(expense) recognized in OCI of the previous periods	15.564	-2.929
<b>Total at 31 December</b>	<b>-343.819</b>	<b>-334.860</b>

## Assets

### 13. Intangible assets

(In thousands of EUR)	Licences and similar rights	Research costs	Total
Acquisition value at 1 January 2016	4.745	273.485	278.230
Acquisitions	4	37.010	37.014
<b>Acquisition value at 31 December 2016</b>	<b>4.749</b>	<b>310.495</b>	<b>315.244</b>
Amortization and impairment at 1 January 201	3.540	169.104	172.644
Amortization	428	45.396	45.824
<b>Amortization and impairment at 31 December 2016</b>	<b>3.968</b>	<b>214.500</b>	<b>218.468</b>
<b>Net book value at 31 December 2016</b>	<b>781</b>	<b>95.995</b>	<b>96.776</b>

(In thousands of EUR)	Licences and similar rights	Research costs	Total
Acquisition value at 1 January 2015	19.958	230.527	250.485
Acquisitions	333	42.958	43.291
Other	-15.546	0	-15.546
<b>Acquisition value at 31 December 2015</b>	<b>4.745</b>	<b>273.485</b>	<b>278.230</b>
Amortization and impairment at 1 January 2015	18.608	125.318	143.926
Amortization	478	43.786	44.264
Other	-15.546	0	-15.546
<b>Amortization and impairment at 31 December 2015</b>	<b>3.540</b>	<b>169.104</b>	<b>172.644</b>
<b>Net book value at 31 December 2015</b>	<b>1.205</b>	<b>104.381</b>	<b>105.586</b>

The investments for the projects smart metering, smart grids, smart users (as from 2012) and district heating (as from 2014) are recorded as 'Development costs'. The acquisitions for the project smart metering amounted to 5.780 k EUR for 2016 and 9.97 k EUR for 2015.

No research costs are included in the income statement for 2016 and 2015.

There were no intangible assets with an indefinite useful life.

## 14. Property, plant and equipment

(In thousands of EUR)	Land and buildings	Installation, machinery and equipment	Furniture and vehicles	Others	Assets under construction	Total
Acquisition value at 1 January, 2016	270.961	12.861.877	185.232	19.085	161.044	13.498.199
Acquisitions	5.791	23.392	7.655	822	301.570	339.230
Sales and disposals	-1.105	-175.332	-5.640	-790	-3.765	-186.632
Transfer to others	596	186.705	0	-324	-186.983	-6
<b>Acquisition value at 31 December, 2016</b>	<b>276.243</b>	<b>12.896.642</b>	<b>187.247</b>	<b>18.793</b>	<b>271.866</b>	<b>13.650.791</b>
Depreciation and impairment at 1 January, 2016	94.454	5.422.764	161.968	18.428	0	5.697.614
Depreciation	4.394	268.385	9.720	177	0	282.676
Sales and disposals	-881	-126.354	-5.601	-753	0	-133.589
Transfer to others	0	327	0	-327	0	0
<b>Depreciation and impairment at 31 December, 2016</b>	<b>97.967</b>	<b>5.565.122</b>	<b>166.087</b>	<b>17.525</b>	<b>0</b>	<b>5.846.701</b>
<b>Net book value at 31 December, 2016</b>	<b>178.276</b>	<b>7.331.520</b>	<b>21.160</b>	<b>1.268</b>	<b>271.866</b>	<b>7.804.090</b>

(In thousands of EUR)	Land and buildings	Installation, machinery and equipment	Furniture and vehicles	Others	Assets under construction	Total
Acquisition value at 1 January, 2015	260.992	12.657.106	397.202	19.062	3.738	13.338.100
Acquisitions	7.249	213.522	10.554	23	160.880	392.228
Sales and disposals	-1.847	-177.776	-52.506	0	0	-232.129
Transfer to others	4.567	169.025	-170.018	0	-3.574	0
<b>Acquisition value at 31 December, 2015</b>	<b>270.961</b>	<b>12.861.877</b>	<b>185.232</b>	<b>19.085</b>	<b>161.044</b>	<b>13.498.199</b>
Depreciation and impairment at 1 January, 2015	90.749	5.141.245	343.864	16.618	0	5.592.476
Depreciation	3.948	278.106	8.977	1.810	0	292.841
Acquisitions from third parties	680	2	345	0	0	1.027
Sales and disposals	-1.335	-135.142	-52.253	0	0	-188.730
Transfer to others	412	138.553	-138.965	0	0	0
<b>Depreciation and impairment at 31 December, 2015</b>	<b>94.454</b>	<b>5.422.764</b>	<b>161.968</b>	<b>18.428</b>	<b>0</b>	<b>5.697.614</b>
<b>Net book value at 31 December, 2015</b>	<b>176.507</b>	<b>7.439.113</b>	<b>23.264</b>	<b>657</b>	<b>161.044</b>	<b>7.800.585</b>

The acquisitions reported in the item 'Installations, machinery and equipment' mainly relate to the investments in mid and low voltage electricity networks for a total value of 136.637 k EUR in 2016 and 167.615 k EUR in 2015 and investments in gas pipe lines and gas connections for a value of 87.015 k EUR in 2016 and 111.582 k EUR in 2015.

The commitments for the acquisition of property, plant and equipment at the end of 2016 amounted to 4.698 k EUR and 3.570 k EUR at the end of 2015. A commitment to sell property, plant and equipment existed at the end of 2016 for 8.442 k EUR and 500 k EUR at the end of 2015.

The net book value includes the assets paid by clients (third party intervention) and corresponds to the fair value of the Group's network.

As per 31 December 2016 and 2015, there are no restrictions on title and property, plant and equipment serving as pledge for liabilities.

## 15. Investment in other companies

The investments in other companies amount to 30 k EUR at the end of 2016 and 11 k EUR at the end of 2015. These investments are held in Atrias cvba, Synductis cvba and the newly created companies Warmte@Vlaanderen cvba and Fluvius cvba.

On 9 May 2011 Atrias cvba was established as a joint initiative of Belgium's five largest distribution system operators Eandis, Infrax, Ores, Sibelga and RESA.

Atrias is a central clearing house for the Distribution System Operators and charged with the development of a Message Implementation Guide (MIG), the development of a clearing house application, and the management and maintenance of this application. MIG describes how the communication flow between the various players of the energy market should happen.

The Group has acquired 25 % of the shares representing an amount of 5 k EUR.

Atrias is an unlisted company and has no official price quotation.

Synductis cvba was founded on 21 December 2012 and aims to coordinate the infrastructure works by various utility companies in the Flemish cities and municipalities and so reduce nuisance of the works.

The various utility companies participating for coordination of the works in synergy are: Eandis System Operator (distribution of gas and electricity), Farys/TMVW (Tussengemeentelijke Maatschappij der Vlaanderen voor Watervoorziening), I.W.V.A. (Intercommunale Waterleidingsmaatschappij van Veurne-Ambacht), I.W.V.B. (Intercommunale voor Waterbedeling in Vlaams-Brabant) and Proximus (telecommunication). Other companies are preparing an affiliation.

The Group holds an investment of 6 k EUR or 33,24 % of the shares.

Synductis is an unlisted company and has no official price quotation.

The Group receives its share of the operating costs of Atrias and Synductis. But the Group also grants services and funding (see note 'Related parties').

During 2016, the Group participates for 50,00 % in the newly formed company Warmte@Vlaanderen cvba (amounting to 9 k EUR) and also for 50,00 % in the company Fluvius cvba (amounting to 9 k EUR). The latter is a common company of Eandis System Operator and Infrax (distribution operator for natural gas, electricity, cable television and sewerage in the Flemish region) so that closer cooperation is enhanced. A first activity that will be carried out in

this company comprises the development of the 'smart end-to-end' chain (smart meters, data communication). Other activities and synergy opportunities are under further investigation.

## 16. Other investments

The other investments comprise the participations still held by the Group in the business centres situated in the distribution area of Gaselwest (business centres Kortrijk, Roeselare, Flemish Ardennes and Waregem) and Imewo (business centres Bruges, Ghent, Meetjesland and Ostend). The other investments amount to 832 k EUR at the end of December 2016 (2015: 919 k EUR). This decrease is due to the sale of the business centre Kempen (see note 'Financial results'-financial income).

## 17. Long term receivables

This category consists almost exclusively of loans to local authorities at market conditions and amounted to 1.091 k EUR at the end of 2016 and 1.155 k EUR at the end of 2015.

## 18. Inventories

(In thousands of EUR)	2016	2015
Raw materials and consumables	41.206	46.081
Write down on inventories	-5.912	-765
<b>Total</b>	<b>35.295</b>	<b>45.316</b>

The impairment losses amounted to 5.147 k EUR in 2016 (2015: 272 k EUR). These amounts were reported in the income statement.

## 19. Trade and other receivables

(In thousands of EUR)	2016	2015
Trade receivables - gross	503.356	427.015
Impairment	-76.054	-75.763
<b>Total trade receivables - net</b>	<b>427.302</b>	<b>351.252</b>
Other receivables	570.196	643.882
Other receivables - Transfers	679.502	770.826
<b>Total other receivables</b>	<b>1.249.698</b>	<b>1.414.708</b>
<b>Total trade and other receivables</b>	<b>1.677.000</b>	<b>1.765.960</b>

The information regarding outstanding balances with the associate, was included in the note 'Related parties'.

The detail of the **trade receivables – net** is as follows.

(In thousands of EUR)	2016	2015
<b>Trade receivables from distribution grid activities</b>		
Outstanding debt	252.842	235.425
Impairment	0	0
<b>Trade receivables social customers</b>		
Outstanding debt	101.770	101.429
Impairment	-62.115	-62.556
<b>Other trade receivables</b>		
Outstanding debt	117.366	51.743
Construction works for third parties	25.756	29.041
Impairment	-13.938	-13.207
<b>Trade receivables public authorities, state and country</b>	2.206	4.211
<b>Other</b>	3.415	5.166
<b>Total trade receivable - net</b>	<b>427.302</b>	<b>351.252</b>

The trade receivables from distribution grid activities increase further with 17.417 k EUR and amount to 252.742 k EUR at the end of 2016.

The net amount of trade receivables from social customers remain at the same level and amount to 39.655 k EUR in 2016 and 38.873 k EUR in 2015.

The 'Other trade receivables' include an amount of 437 k EUR for 2016 and 566 k EUR for 2015 related to bad debts from the period before the energy market's liberalization, as well as receivables related to finished construction works and services rendered and costs still to be



billed related to works for third parties. In 2016, an amount of 48.400 k EUR was recorded as 'Other trade receivables, outstanding debts' for the debt relating to the sale of green certificates.

The trade receivables from distribution grid activities are payable within 18 calendar days following the dispatch of the invoice as provided in the Access Code.

The detail of the **other receivables** is as follows.

(In thousands of EUR)	2016	2015
VAT receivable	10	88
Receivables municipalities	8	93
Green energy and cogeneration certificates	546.107	627.085
Receivables options	6.743	3.506
Others	17.328	13.110
<b>Other receivables</b>	<b>570.196</b>	<b>643.882</b>
Transfer tariff	587.234	658.965
Complement to annual energy sales	56.673	57.807
Financial reconciliation	0	0
Solidarity receivables related to the certificates for green energy	16.892	16.993
Deferred charges	5.395	11.249
Accrued income	13.308	25.812
<b>Other receivables - Transfers</b>	<b>679.502</b>	<b>770.826</b>
<b>Total other receivables</b>	<b>1.249.698</b>	<b>1.414.708</b>

The decrease in other receivables with 165.010 k EUR to 1.249.698 k EUR was mainly due to the decrease of the items 'Green energy and cogeneration certificates (REC & CHPC)' with 80.978 k EUR and the item 'Transfer tariff' with 71.731 k EUR compared to the end of December 2015.

The RECs and CHPCs amount to 546.107 k EUR at the end of December 2016 compared to 627.085 k EUR at the end of December 2015.

The DSOs are required to buy renewable energy certificates, which are offered by the owners of solar panels and combined heat and power plants, at a certain amount (minimum support for solar panels between 450 euros and 90 euros; for cogeneration 27 euros and 31 euros). The electricity suppliers need to deliver a certain quantity of green electricity and combined heat and power certificates to the regulator which is in relation to a certain percentage of the delivered amount of energy. Hence, the DSOs can offer these certificates to the energy suppliers.

The sales price in this market, however, is significantly lower than the minimum paid out by the DSOs for the certificates. The value of the unsold certificates of the DSOs was 88 euros per certificate for the not guaranteed green energy certificates and to 20 euros per certificate for the not guaranteed combined heat and power certificates. The resulting cost is included in the post 'Cost of trade goods'.

During 2016 and 2015, the certificates were offered for sale on a quarterly basis. A total amount of 219.116 k EUR of RECs were sold in 2016 (2015: 22.540 k EUR) and for 1 k EUR CHPCs

(2015: 44.022 k EUR). The result from the sale (cost) amounts to 2.137 k EUR (profit in 2015: 87 k EUR) and has been included in the item 'Cost of trade goods'.

In 2016, a DAEB ('dienst van algemeen economisch belang') arrangement was entered into to decrease the large stock of green energy certificates with the DSOs. As a result, the RECs, submitted by the solar panels owned by families, could be sold by the DSOs for a maximum amount of 15.000 k EUR per DSO to VEA (Flemish Energy Agency). These certificates are then destroyed. This arrangement is valid for a period of 10 years until 2026. In total this transaction had a positive effect of 104.506 k EUR in 2016. Since already interest was levied on the outstanding amount of certificates, this financial income was deducted from the total receivable of 105.000 k EUR.

**Transfer tariff** amount to 587.234 k EUR at the end of December 2016 and relate to the revenue correction that is eligible for inclusion in the following tariff period (see note 'Working in a regulated environment – The billing mechanism').

The **complement to the annual energy sales** concerns the estimate of the energy supplied to social customers but not yet invoiced.

#### **Solidarity contribution for RECs**

The cost of green power differs greatly for each distribution area in Flanders. In the Energy Decree, the distribution system operators are committed to a mutual settlement of the costs since 2010. The principles and procedures are initiated by the VREG (Flemish Regulator for Electricity and Gas).

Since the settlement can be both a receivable or a liability, this item must be read together with the item reported in the notes 'Trade and other payables'.

The **deferred charges and accrued income** mainly concern the amounts to be settled on the purchase of energy.

## **20. Cash and cash equivalents**

Cash and cash equivalents comprise bank deposits, cash resources and fund investments that are readily exchangeable into cash. At the end of 2016 an amount of 2.708 k EUR was available and 3.656 k EUR at the end of 2015.

All resources are reported in euro.

## Liabilities

### 21. Issued capital and reserves

The various components of equity and the movements from 1 January 2015 to 31 December 2016 were reflected in the 'Statement of changes in equity'.

The **share capital** amounted to 1.262.948 k EUR at the end of 2016 and 1.278.688 k EUR at the end of December 2015. The capital was fully subscribed and paid up. It represents the sum of the capitals of the DSOs.

Date	Transaction	Amount in k EUR
<b>1 January 2015</b>		<b>2.056.752</b>
2 January 2015	Capital decrease – exit Electrabel	-885.798
9 January 2015	Capital increase - public shareholders	61.589
1 April 2015	Capital increase - public shareholders	26.998
29 June 2015	Capital increase - public shareholders	29.147
29 December 2015	Capital decrease - public shareholders	-10.000
<b>31 December 2015</b>		<b>1.278.688</b>
1 January 2016	Capital decrease - exit Frasnés-lez-Anvaing	-565
30 June 2016	Capital decrease - exit province East-Flanders and province Antwerp	-15.175
<b>31 December 2016</b>		<b>1.262.948</b>

In 2015, the funding of the exit at 29 December 2014 of the private partner Electrabel was concluded and resulted in a capital decrease of 885.798 k EUR on 2 January 2015.

On 9 January 2015 certain municipalities from the DSOs Gaselwest, Imewo, Intergem, Iveka and Iverlek subscribed to a capital increase for a total amount of 61.589.310,01 euro. This capital increase was organized to optimize the capital-cost structure (fair remuneration) of the equity of the shareholders. The proposed capital increase represented a total amount of 236,3 million euro which was only partially subscribed.

In the second quarter of 2015 the enrollment period of the previous capital increase was re-opened, with the same terms as the initial capital increase. In June 2015, 29.146.555,36 euro was subscribed to.

In April 2015, Sibelgas also subscribed for an amount of 26.998.441,32 euro in the capital.

Finally, Sibelgas reduced its capital on 29 December 2015 for 10.000.000,00 euro to balance the capital ratio with the other DSOs. The amount was recorded as a liability and is disclosed in the note 'Trade and other payables'.

On 1 January 2016, one of the Walloon municipalities (Frasnés-lez-Anvaing) decided to exit the DSO Gaselwest and to switch to Ores, the Walloon network operator.

The final settlement is subject to the approval of the regulatory balances by the regulator.

(In thousands of EUR)	Frasnes-Lez-Anvaing
Property, plant & equipment	7.426
Current assets	45
<b>Total assets</b>	<b>7.471</b>
Equity	1.240
Current liabilities: trade payables	6.231
<b>Total equity and liabilities</b>	<b>7.471</b>

On 27 April 2016, the Flemish Parliament approved an adjustment to the Decree on Intermunicipal Cooperation whereby the provinces, shareholders of the DSOs, must exit no later than the end of 2018. The provinces of Oost-Vlaanderen/East Flanders and Antwerp decided to exit on 30 June 2016 and the province of West-Vlaanderen/West-Flanders will withdraw by the end of 2018. The exit led to a decrease in equity of 38.429 k euro and the shares, previously held by these two provinces, were destroyed.

The table below shows the movements in the number of shares and profit certificates per category in the capital of each DSO at the end of 2016.

DSO	Shares A		Profit certificates C		Total	
	Number	Share Capital (in €)	Number	Share Capital (in €)	Number	Share Capital (in €)
Gaselwest	23.380.013	271.033.935,03	116	0,00	23.380.129	271.033.935,03
IMEA	13.397.899	126.070.700,07	12	0,00	13.397.911	126.070.700,07
Imewo	21.585.912	257.170.000,11	85	0,00	21.585.997	257.170.000,11
Intergem	11.120.262	97.527.148,81	46	0,00	11.120.308	97.527.148,81
Iveka	17.003.557	186.138.498,91	86	0,00	17.003.643	186.138.498,91
Iverlek	29.444.704	254.083.895,51	103	0,00	29.444.807	254.083.895,51
Sibelgas(1)(2)	3.264.382	70.924.041,47	0	0,00	3.264.382	70.924.041,47
<b>Total</b>	<b>119.196.729</b>	<b>1.262.948.219,91</b>	<b>448</b>	<b>0,00</b>	<b>119.197.177</b>	<b>1.262.948.219,91</b>

(1) Shares C

(2) In Sibelgas, 10.000 shares D are issued without representation in the share capital.

The table below shows the movements in the number of shares and profit certificates per category in the capital of each DSO at the end of 2015.

DSO	Shares A and C		Profit certificates C		Total	
	Number	Capital (In €)	Number	Capital (In €)	Number	Capital (In €)
Gaselwest	23.516.814	272.550.409,97	119	0,00	23.516.933	272.550.409,97
IMEA	13.397.899	126.070.700,07	12	0,00	13.397.911	126.070.700,07
Imewo	21.661.488	257.867.873,74	87	0,00	21.661.575	257.867.873,74
Intergem	11.178.550	97.961.020,49	48	0,00	11.178.598	97.961.020,49
Iveka	18.442.017	199.230.489,93	93	0,00	18.442.110	199.230.489,93
Iverlek	29.444.704	254.083.895,51	103	0,00	29.444.807	254.083.895,51
Sibelgas (1) (2)	3.264.382	70.924.041,47	0	0,00	3.264.382	70.924.041,47
<b>Total</b>	<b>120.905.854</b>	<b>1.278.688.431,18</b>	<b>462</b>	<b>0,00</b>	<b>120.906.316</b>	<b>1.278.688.431,18</b>

(1) Shares C

(2) In Sibelgas, 10.000 shares D are issued without representation in the share capital and 3 shares C.

The overview of the **reserves** is as follows:

(In thousands of EUR)	Legal reserves	Unavailable reserves	Available reserves	Total
Total at 1 January 2015	1.052	0	678.750	679.802
Transfers to reserves	0	39.288	40.458	79.746
<b>Total at 31 December 2015</b>	<b>1.052</b>	<b>39.288</b>	<b>719.208</b>	<b>759.548</b>
Repayment of equity	0	0	-23.928	-23.928
Transfers to reserves	0	40.874	35.359	76.233
Transfers from reserves	0	0	-212	-212
<b>Total at 31 December 2016</b>	<b>1.052</b>	<b>80.162</b>	<b>730.427</b>	<b>811.641</b>

A *legal reserve* has been formed amounting to 1.052.134,94 EUR.

Since 2008 amounts were included as *unavailable reserve* equal to the depreciation of the (RAB-added value) revaluation surplus value in accordance with the settlement with the CREG. From 2010 onwards, the costs of the surplus value of land, buildings and installations sold during the accounting year were taken into account. The addition to the reserves for 2016 amounted to 40.874 k EUR and 39.288 k EUR for 2015.

Furthermore, it was decided to transfer during 2014 the total of the unavailable reserves of 380.801 k EUR to the available reserves (see below) in order to balance the account at 1 January 2015.

The total *available reserves* at the end of 2016 amounted to 730.427 k EUR (2015: 719.208 k EUR). The increase in 2016 amounting to 35.359 k EUR (2015: 40.458 k EUR) stems from the result of the year.

The repayment of euro 23.928 k EUR refers to the exit of the various shareholders during 2016.

The other components of equity i.e. **other comprehensive income** for 2016 amounted to 641.178 k EUR (2015: 651.430 k EUR) and contain the accumulated actuarial losses relating to pensions and other post-employment employee benefits amounting to 146.775 k EUR and since 2014 also the effect of the recording of deferred taxes for an amount of 494.403 k EUR.

The movement of the actuarial differences for employee benefits is for 2016 a loss and amounts to 5.311 k EUR (2015: a profit of 51.003 k EUR) - see note 'Pensions and other post-employment employee benefit plans'.

The movement of the deferred taxes was explained in the note 'Income tax expenses'.

The other comprehensive income is composed of the following:

(In thousands of EUR)	2016	2015
Long term employee benefits	-146.775	-141.464
Deferred tax	-494.403	-509.967
<b>Total</b>	<b>-641.178</b>	<b>-651.431</b>

A **non-controlling interest** decreases from 1.079 k EUR in December 2015 to 93 k EUR in December 2016 as a result of the merger by acquisition of Indexis by Eandis System Operator.

The non-controlling interest at the end of December 2016 includes the interest held by third parties in De Stroomlijn.

### Dividend

During the accounting year 2016 dividends were paid for a total value of 165.752 k EUR and 185.625 k EUR in 2015.

Below is an overview of the dividends paid per DSO for 2016 and 2015.

DSO (In thousands of EUR)	2016	2015
Gaselwest	37.816	42.155
IMEA	15.453	16.525
Imewo	35.732	40.683
Intergem	16.289	17.926
Iveka	22.335	26.839
Iverlek	33.629	36.764
Sibelgas	4.498	4.733
<b>Total</b>	<b>165.752</b>	<b>185.625</b>

After the balance sheet date the Board of Directors of each of the DSOs has formulated a dividend proposal. At their DSO's General Assembly, the shareholders have approved the payment of these dividend balances. According to IFRS these dividends are only reported in the year in which the dividends have been approved. The dividend balance for 2016 amounted to 21.397 k EUR and will be included in the 2017 accounts, the dividend balance for 2015 amounted to 1.758 k EUR and was included in the 2016 accounts.

The amounts mentioned are the net dividends before withholding tax.

The Group's **profit** comprises the capital cost remuneration (fair remuneration), as described in the chapter 'Operating in a regulated environment'.

## 22. Interest bearing loans and borrowings

(In thousands of EUR)	2016	2015
<b>Long term loans</b>	<b>5.244.409</b>	<b>5.197.393</b>
Current portion of long term loans	355.388	738.558
Short term loans	411.309	225.238
<b>Short term loans</b>	<b>766.696</b>	<b>963.795</b>
<b>Total</b>	<b>6.011.105</b>	<b>6.161.189</b>

At the balance sheet date of 2016, the total amount of loans and borrowings decreases with 150.083 k EUR compared to 2015.

All loans are expressed in euro.

The **movements of the long and short-term loans** can be analyzed as follows:

(In thousands of EUR)	2016		2015	
	Cash	Non-cash	Cash	Non-cash
Total at 1 January	6.161.189		6.049.680	
<b>Movements on non-current loans (LT)</b>				
Proceeds of non-current loans	400.000	0	400.000	0
Change in non-current loans	0	2.404	0	2.397
Transfer of ST portion of LT loans to ST	0	-355.388	0	-738.558
<b>Movements on current loans (ST)</b>				
Proceeds of current loans	411.309	0	225.238	0
Transfer of ST portion from LT loans to ST	0	355.388	0	738.558
Repayment of short term portion of LT loan	-738.558	0	-516.126	0
Repayment current loans	-225.238	0	0	0
<b>Total movements</b>	<b>-152.487</b>	<b>2.404</b>	<b>109.112</b>	<b>2.397</b>
<b>Total at 31 December</b>	<b>6.011.105</b>		<b>6.161.189</b>	

## Long term loans

Overview of the long term loans by category  
At the end of 2016

(In thousands of EUR)	2016	Initial amount	Current interest rate %	Maturity
Bond issue - retail	319.958	320.000	4,00 - 4,25	2017-2020
Bond issue - EMTN*	2.642.164	2.660.500	1,75 - 4,50	2021-2033
Bond issue - private**	435.042	440.000	2,60 - 3,55	2027-2044
Bank loans - fixed interest rate	1.494.381	1.950.000	0,92 - 4,76	2019-2036
Bank loans - with derivative instrument	708.252	1.270.000	2,97 - 4,56	2023-2027
<b>Total</b>	<b>5.599.797</b>	<b>6.640.500</b>		
Current portion of long term debt	-355.388			
<b>Total long term loans</b>	<b>5.244.409</b>			

At the end of 2015

(In thousands of EUR)	2015	Initial amount	Current interest rate %	Maturity
Bond issue - retail	319.970	320.000	4,00 - 4,25	2017-2020
Bond issue - EMTN*	2.639.987	2.660.500	1,75 - 4,50	2021-2033
Bond issue - private**	434.803	440.000	2,60 - 3,55	2027-2044
Bank loans - fixed interest rate	1.761.385	2.350.000	1,24 - 4,76	2016-2035
Bank loans - variable interest rate	34	53.153	0,88 - 2,68	2016
Bank loans - with derivative instrument	779.771	1.270.000	2,97 - 4,56	2023-2027
<b>Total</b>	<b>5.935.951</b>	<b>7.093.653</b>		
Current portion of long term debt	-738.558			
<b>Total long term loans</b>	<b>5.197.393</b>			

\* EMTN: Euro Medium Term Note (is a programme to provide to the Group the flexibility to issue bond loans with different maturities).

\*\* Private: bond issues according to German law: Schuldschein and Namensschuldverschreibung as well as private issues to institutionals (stand alone).

For bank loans – with derivative instrument the Group subscribed to interest rate swaps in order to swap the variable interest rate to a fixed interest rate or some forward interest swaps were concluded (see note ‘Derivative financial instruments’).

For the bond loans issued by Eandis System Operator, each of the DSOs is guarantor on a non-joint and non-inclusive basis but limited to its proportional share in the capital of Eandis System Operator cvba.



## Overview of the long term loans issued and borrowings during 2016 and 2015

(In thousands of EUR)	2016	2015	Initial amount	Interest rate %	Maturity
Bank loans (fixed interest rate)	150.000	0	150.000	0,92	2026
Bank loans (fixed interest rate)	100.000	0	100.000	1,57	2036
Bank loans (fixed interest rate)	150.000	0	150.000	1,38	2036
<b>Total 2016</b>	<b>400.000</b>	<b>0</b>	<b>400.000</b>		
Bank loans (fixed interest rate)	382.759	400.000	400.000	1,52	2035
<b>Total 2015</b>	<b>382.759</b>	<b>400.000</b>	<b>400.000</b>		

### Short term loans

The loans on short-term contain the portion of the long-term loans which are repayable within one year (355.388 k EUR on year end 2016, 738.558 k EUR on year end 2015) and the loans drawn with financial institutions as reported below:

(In thousands of EUR)	Maturity	Available amounts	Amounts used	Amounts not used	Average interest rate % (3)
Commercial paper	(1)	522.000	355.000	167.000	0,06
Fixed advances		200.000	0	200.000	Nvt
Fixed loans/Bank overdraft (3)	Daily	200.000	56.309	143.691	0,50
Fixed loans		100.000	0	100.000	Nvt
<b>Total at 31 December 2016</b>		<b>1.022.000</b>	<b>411.309</b>	<b>610.691</b>	
Commercial paper	(2)	522.000	166.800	355.200	0,09
Fixed advances		200.000	0	200.000	Nvt
Fixed loans/Bank overdraft (3)	Daily	200.000	58.438	141.562	0,70
Fixed loans		100.000	0	100.000	Nvt
<b>Total at 31 December 2015</b>		<b>1.022.000</b>	<b>225.238</b>	<b>796.762</b>	

(1) 50.000 k€ at 13/1/2017, 50.000 k€ at 31/1/2017, 155.000 k€ at 7/2/2017 and 100.000 k€ at 13/2/2017

(2) 65.000 k€ at 18/1/2016 and 101.800 k€ at 29/1/2016

(3) The average interest rate of the used amounts at the end of the period

All short-term loans are subscribed by Eandis System Operator in the name and on behalf of the Distribution System Operators that stand surety for their part and act as joint co-debtor except for the bank overdrafts.

## 23. Pensions and other post-employment employee benefit plans

### Defined contribution plans

Employees hired after 1 January 2002 and the executive staff hired after 1 May 1999 are entitled to defined contribution plans: these pension plans provide in a lump sum on retirement resulting from the contributions paid and the return granted by the pension institutions, as well as a lump sum and orphan interests in case of decease before retirement.

The financing is carried out by employee contributions and employer contributions that are deposited in pension funds (Powerbel and Enerbel) and group insurances.

The assets are managed within a Luxembourg Fund (Esperides), divided in 4 investment zones, each representing a different risk profile (low risk, medium risk, high risk and dynamic asset allocation). The risk level also has to be managed taking into account the age of the members. This is why the trustees of Powerbel have proposed to the members a new option (2015) to manage their assets. This option, called 'Life-Cycle', offers an evolution of the risk exposure from growth to more defensive throughout the member's career.

### Investment risk

Due to the declining level of the interest rates of the bonds, pension institutions, managing the DC-plans, faced the challenge to continue to cover the level of the guaranteed interest rates. A reform was imposed and was announced with the publication on 24 December 2015 of the Act of 18 December 2015 guaranteeing the sustainability and the social character of supplementary pensions and strengthening the complementary nature with respect to the retirement pension plans. This law entered into force on 1 January 2016.

The amendment implies that the DC pension plans are to be valued as from 1 January 2016 according to the Projected Unit Credit (PUC) method without projection of future contributions. Until 2015 the intrinsic valuation method was applied.

The guaranteed interest will now be variable and each year will be aligned to the average return over the last 24 months of linear bonds of the Belgian State (OLOs) with a duration of 10 years (at least 1,75 % and maximum 3,75 %).

The new interest rate for 2016 is 1,75 % and is applied, according to the vertical method, for all contributions paid to the pension funds and in the insurance company (products of TAK 21 with interest guarantee).

The pension funds are not subject to the Solvency II regulation of insurance companies and can obtain better expected returns by diversification of their investments. Hence, the reserves and a compensation of the group insurance was transferred during 2016 to a pension fund OFP Powerbel/OFP Enerbel as a cash-balance plan with a minimum guaranteed return of 3,25 % (see table Classification of the plan investments on the balance sheet date).

### Defined benefit plans

The Collective Labour Agreement of 2 May 1952 stipulated an additional pension equal to 75 % of the last annual salary after deduction of the legal pension at the end of a complete career, as well as a survival pension and an orphan allowance. This defined benefit plan has been fully paid up by the employer and the pensions have been paid out directly to the beneficiaries. The remaining subsequent obligations are for the largest part related to current pensions.

The majority of the employees hired before 1 January 2002 and the executive staff hired before 1 May 1999 are entitled to defined benefit plans which provide in the payment of a lump sum on retirement, and a lump sum and orphan interest in case of decease before retirement. These benefits are calculated taking into account the last annual salary and past service. The financing

is carried out by employee contributions and employer contributions that are deposited in pension funds (O.F.P. Elgabel and O.F.P. Pensiobel) and group insurances.

Due to changes to the pension regulation in Belgium, the members of the pension plan Pensiobel were offered the opportunity to move as from 1 January 2015 to the defined contribution plan Powerbel. The accumulated and improved acquired rights (in Pensiobel) are capitalized at market returns but with a minimum return equal to 3,25 % (cash-balance plan).

The Group also grants **post-retirement allowances** being reimbursement of healthcare costs and tariff benefits.

The **other long-term employee benefits** contain provisions for retirement and jubilee bonuses.

### **Actuarial risks**

The defined benefit plans expose the Group to various actuarial risks:

#### *Investment risk*

The present value of the defined benefit plan liability is calculated using a discount rate determined to high quality corporate bond yields. If the return on plan asset is below this rate, it will create a plan deficit. Currently, the plan has a relatively balanced investment which is reported in the table below 'Classification of the plan investments on the balance sheet date'.

Due to the long-term nature of the plan liabilities, the board of the pension fund considers it appropriate that a reasonable portion of the plan assets should be invested in equity securities to leverage the return generated by the funds.

#### *Interest rate risk*

A decrease in the bond interest rate will increase the plan liability. However, this will be partially offset by an increase in the return on the plan's debt investments.

#### *Longevity risk*

The present value of the defined benefit plan liability is calculated by reference to the best estimate of the mortality of plan participants both during and after their employment. An increase in the life expectancy of the plan participants will increase the plan's liability.

From 2015 onwards, new prospective mortality tables are used as proposed by the Institute of Actuaries in Belgium (IA|BE).

#### *Salary risk*

The present value of the defined benefit plan liability is calculated by reference to the future salaries of plan participants. As such, an increase in the salary of the plan participants will increase the plan's liability.

The major actuarial assumptions used at balance sheet date to determine the provision for employee benefits and other allowances:

	2016	2015
Discount rate - pensions	1,28%	1,96%
Discount rate - others	1,77%	1,96%
Expected average salary increase (excluding inflation)	0,85%	0,85%
Expected inflation	1,65%	1,65%
Expected increase of health benefits (including inflation)	2,65%	2,65%
Expected increase of tariff advantages	0,25%	0,25%
Average assumed retirement age	63	62
	IA BE	IA BE
	Prospective	Prospective
	Tables	Tables
Mortality table used		
Life expectancy in years of a pensioner retiring at age 65:		
For a Person aged 65 at closing date:		
- Male	20	20
- Female	24	24
For a Person aged 65 in 20 years:		
- Male	22	22
- Female	26	26

### Amounts recognized in comprehensive income

(In thousands of EUR)	2016	2015
<b>Service cost</b>		
Current service cost	-34.741	-16.592
Cost of early retirement	-26	1.075
Past service cost	0	-5.672
Actuarial (gains)/losses on other long-term benefits	-8.069	3.444
<b>Net interest on the net defined benefit liability/(asset)</b>		
Interest cost on defined benefit obligation	-16.851	-13.124
Interest income on plan assets	11.229	7.360
<b>Defined benefit costs recognized in profit or loss</b>	<b>-48.457</b>	<b>-23.509</b>
<b>Actuarial gains/(losses) on defined benefit obligation arising from</b>		
i) changes in demographic assumptions	26.827	1.414
ii) changes in financial assumptions	-81.571	40.584
iii) changes from experience adjustments	-40.669	24.599
Return on plan assets (excluding interest income)	90.102	-15.595
<b>Remeasurements of net defined benefit liability/(asset) recognized in Other Comprehensive Income (OCI)</b>	<b>-5.311</b>	<b>51.003</b>
<b>Total</b>	<b>-53.769</b>	<b>27.494</b>

### Amounts recognized in the balance sheet

(In thousands of EUR)	Present value of funded defined benefit obligation	Fair value of plan assets	Funded status
Pensions - funded status	670.981	-657.662	13.319
Pensions - unfunded status	25.134	0	25.134
Healthcare costs, tariff benefits - unfunded status	165.464	0	165.464
Other long-term employee benefits - funded status	69.304	-13.858	55.446
<b>Total defined benefit obligation and long-term employee benefits at 31 December 2016</b>	<b>930.883</b>	<b>-671.520</b>	<b>259.363</b>
Pensions - funded status	436.719	-508.159	-71.440
Pensions - unfunded status	174.132	0	174.132
Healthcare costs, tariff benefits - unfunded status	168.562	0	168.562
Other long-term employee benefits - funded status	63.378	-3.382	59.995
<b>Total defined benefit obligation and long-term employee benefits at 31 December 2015</b>	<b>842.792</b>	<b>-511.541</b>	<b>331.250</b>

### Changes in the present value of the obligation

(In thousands of EUR)	2016	2015
Total at 1 January	842.791	951.033
Current service cost	30.960	15.822
Interest cost	16.851	13.124
Contributions from plan participants	3.781	770
Cost of early retirement	26	-1.075
Remeasurement (gains)/losses in Other Comprehensive Income (OCI) arising from		
i) changes in demographic assumptions	-23.827	-1.250
ii) changes in financial assumptions	87.769	-43.086
iii) changes from experience adjustments	39.391	-25.932
Taxes on contributions paid	-2.087	-2.824
Past service cost	0	5.672
Payments from the plan	-64.772	-69.464
<b>Total at 31 December</b>	<b>930.883</b>	<b>842.792</b>

## Changes in the fair value of the plan assets

(In thousands of EUR)	2016	2015
Total at 1 January	-511.541	-525.959
Interest income	-11.229	-7.360
Remeasurement gains/(losses) in Other Comprehensive Income (OCI) arising from return on plan assets (excluding amounts included in net interest expense)	-89.953	15.822
Contributions from employer	-119.787	-60.260
Contributions from plan participants	-3.781	-770
Benefit payments	64.771	66.987
<b>Total at 31 December</b>	<b>-671.520</b>	<b>-511.541</b>
<b>Actual return on plan assets</b>	<b>-101.182</b>	<b>8.462</b>

## Classification of the plan investments on the balance sheet date

The classification of the plan investments in function of the major category at the end of 2016

Category	Currency	Elgabel %	Pensiobel %	Insurance companies %	Powerbel and Enerbel %	Total %
<b>Investments quoted in an active market</b>		<b>88,80</b>	<b>88,80</b>	<b>74,88</b>	<b>88,80</b>	<b>87,99</b>
Shares	Eurozone	21,52	21,52	4,34	21,52	<b>20,52</b>
	Outside					
Shares	Eurozone	26,68	26,68	2,71	26,68	<b>25,29</b>
Government bonds	Eurozone	0,00	0,00	23,74	0,00	<b>1,38</b>
Other bonds	Eurozone	20,30	20,30	44,09	20,30	<b>21,68</b>
	Outside					
Other bonds	Eurozone	20,30	20,30	0,00	20,30	<b>19,12</b>
<b>Unquoted investments</b>		<b>11,20</b>	<b>11,20</b>	<b>25,12</b>	<b>11,20</b>	<b>12,01</b>
Property		4,70	4,70	4,57	4,70	<b>4,69</b>
Qualifying insurance contracts		0,00	0,00	3,11	0,00	<b>0,18</b>
Cash and cash equivalents		0,00	0,00	1,94	0,00	<b>0,11</b>
Other		6,50	6,50	15,50	6,50	<b>7,03</b>
<b>Total in %</b>		<b>100,00</b>	<b>100,00</b>	<b>100,00</b>	<b>100,00</b>	<b>100,00</b>
<b>Total (In thousands of EUR)</b>		<b>380.111</b>	<b>177.779</b>	<b>38.988</b>	<b>74.642</b>	<b>671.520</b>

The classification of the plan investments in function of the major category at the end of 2015

Category	Currency	Elgabel %	Pensiobel %	Insurance companies %	Total %
<b>Investments quoted in an active market</b>		<b>79,66</b>	<b>80,30</b>	<b>76,73</b>	<b>78,88</b>
Shares	Eurozone	19,88	22,37	3,09	15,21
Shares	Outside Eurozone	16,59	16,08	3,08	12,40
Government bonds	Eurozone	2,83	2,74	14,57	6,38
Other bonds	Eurozone	28,47	27,59	55,99	36,68
Other bonds	Outside Eurozone	11,89	11,52	0,00	8,22
<b>Unquoted investments</b>		<b>20,34</b>	<b>19,70</b>	<b>23,27</b>	<b>21,12</b>
Property		3,92	3,79	4,28	4,01
Qualifying insurance contracts		0,00	0,00	5,47	1,66
Cash and cash equivalents		2,65	2,55	2,03	2,44
Other		13,77	13,35	11,50	13,01
<b>Total in %</b>		<b>100,00</b>	<b>100,00</b>	<b>100,00</b>	<b>100,00</b>
<b>Total (In thousands of EUR)</b>		<b>269.272</b>	<b>86.988</b>	<b>155.281</b>	<b>511.541</b>

#### Breakdown of the defined benefit obligation by type of plan participants and by type of benefits

(In thousands of EUR)	2016	2015
<b>Breakdown of defined benefit obligation by type of plan participants</b>	<b>930.883</b>	<b>842.791</b>
Active plan participants	640.459	557.949
Terminated plan participants with deferred benefit entitlements	53.219	24.498
Retired plan participants and beneficiaries	237.205	260.344
<b>Breakdown of defined benefit obligation by type of benefits</b>	<b>930.883</b>	<b>842.791</b>
Retirement and death benefits	696.115	610.851
Other post-employment benefits (medical and tariff reductions)	165.464	168.562
Jubilee bonuses (Seniority payments)	69.304	63.378

The results of the **sensitivity analysis** are included below to explain the impact of the assumptions.

(In thousands of EUR)	Effect: increase (+) / decrease (-)
Increase of discount rate (0,5%)	-76.972
Average salary increase - excluding inflation (0,5 %)	40.307
Increase of inflation (0,25% movement)	37.422
Increase of healthcare care benefits (1,0%)	21.876
Increase of tariff advantages (0,5 % movement)	4.748
Increase of life expectancy of male pensioners (1 year)	5.120
Increase of life expectancy of female pensioners (1 year)	10.333

The annual balance of the defined benefit lump sum is financed by the Group through a recurrent allocation expressed as a percentage of the total payroll. This percentage is defined by the aggregate cost method and is reviewed annually. This method of financing is used to smooth out future costs over the remaining period of the plan. The costs are estimated on projected bases (salary growth and inflation taken into account).

The assumptions related to salary increase, inflation, employee turnover and age-term are defined on the basis of historical statistics of the Group. The mortality tables used are the ones corresponding to the observed experience within the financing vehicle. The discount rate is set up with regard to the investment strategy of the company.

These assumptions are challenged on a regular basis.

Exceptional events (such as modification of the plan, change of assumptions, too short degree of coverage...) can eventually lead to additional payments by the Group.

The **average duration** of the defined benefit obligation at 31 December 2016 is 9 years (2015: 8 years).

The Group estimates to contribute 42.831 k EUR to the defined benefit pension plans in 2017 and 18.409 k EUR to the defined contribution plans.

## 24. Derivative financial instruments

The Group has entered into interest rate swaps in order to convert the variable interest rate on long term loans into a fixed interest rate. The derivative financial instruments have been measured at fair value for 131.067 k EUR in 2016 and 145.715 k EUR in 2015.

The changes in the fair value are recognized in the income statement (see note 'Financial results').

The fair value of derivative financial instruments entered into for hedging the interest rate risk is calculated on the basis of the discounted expected future cash flows taking into account current market interest rates and the yield curve for the instrument's remaining maturity.

### *Overview of the derivative financial instruments*

A Linear Constant Maturity swap within the framework of the original 200 million EUR loan with a maturity of 20 years concluded in June 2003 entered into force in June 2013.



A Linear Constant Maturity swap within the framework of the original 220 million EUR loan with a maturity of 20 years concluded in December 2004 entered into force in December 2014.

A Linear Constant Maturity swap within the framework of the original 200 million EUR loan with a maturity of 20 year concluded in December 2004 entered into force in December 2009.

A Bonus Range Accrual within the framework of the original 250 million EUR loan with a maturity of 20 year loan concluded in December 2006 entered into force in December 2011.

A Varifix within the framework of the original 250 million EUR loan with a maturity of 20 year concluded in December 2007 entered into force in October 2010.

A forward fixing IRS swap was concluded in July 2013 within the framework of a loan subscribed to in December 2013 for an amount of EUR 150 million over 10 years.

## 25. Provisions, other

(In thousands of EUR)	Site restoration	Other	Total
Total 1 January 2015	19.880	596	20.476
Used	-2.192	-257	-2.449
<b>Total at 31 December 2015</b>	<b>17.688</b>	<b>339</b>	<b>18.027</b>
Used	-2.752	-339	-3.091
<b>Total at 31 December 2016</b>	<b>14.936</b>	<b>0</b>	<b>14.936</b>

The provisions comprise the obligations recognized for the restoration of the former gas factories' grounds. The DSOs own several gas factory grounds on which soil and groundwater have been polluted in the past. Tackling this pollution has already started on a voluntary basis and a framework agreement with OVAM was concluded in 2001. Meanwhile, the number of such grounds has been reduced. In a new agreement with OVAM, it will be determined what the spread in time, the budget, the order of priority and the modalities of execution of the works for rehabilitating the soil, and possibly other measures, will be.

In 2016 an amount of 11.349 k EUR was pledged to OVAM and in 2015 a bank guarantee was given to OVAM for an amount of 10.764 k EUR.

The Group is working on possible sales of certain contaminated sites. In this context, several grounds were already sold and letters of intent were entered into with potential buyers.

On certain grounds already sold, restoration duties still remain for an amount of 860 k EUR in 2016 and 910 k EUR in 2015 (see note 'Contingencies').

The decrease to the provision for site restoration was due to the use of (remediation) and more concrete elements for the estimation of the clean-up costs. No amounts were reversed nor were any amounts added to the provisions during 2016 and 2015.

The provision 'Other' relates to expenses for litigations with third parties and other provisions based upon the management's best possible estimate of the expenses that the Group might incur. During 2016 arrangements were entered into to settle these costs.

## 26. Government grants

(In thousands of EUR)	2016	2015
<b>Total at 1 January</b>	<b>0</b>	<b>0</b>
Received during the year	1.357	0
Released to the income statement	-1	0
<b>Total at 31 December</b>	<b>1.356</b>	<b>0</b>

The Flemish region (Vlaamse Gewest) and the Flemish Energy Agency (Vlaams Energieagentschap) granted capital subsidies to the DSOs for various projects that need to be implemented. These support measures are part of the projects 'green energy'.

## 27. Trade payables and other liabilities

(In thousands of EUR)	2016	2015
Trade debts	213.868	268.099
VAT and other taxes payable	26.571	2.958
Remuneration and social security	76.483	62.756
Advances Soclev clients and other	35.205	34.211
Solidarity payables related to the certificates for green energy	71.416	71.935
Other current liabilities	166.393	207.512
<b>Total</b>	<b>589.936</b>	<b>647.471</b>

The items related to trade payables and other liabilities decrease with 57.535 k EUR in comparison to 2015. The decrease is the result of on the one hand, the decrease in trade payables of 54.231 k EUR and other current liabilities of 41.119 k EUR and on the other hand, the increase of the VAT and other taxes payable and liability for remuneration and social security.

The decrease in trade payables mainly relates to the payment of the debts for the contribution of 100 kWh free of charge (46.645 k EUR).

The major items related to the 'Other current liabilities' comprise a debt to shareholders amounting to 16 k EUR (2015: 10.015 k EUR), the reserved amounts concerning the Bonus 2014 and 2013 amounting to 64.244 k EUR (2015: 64.267 k EUR). This section also contains charges to be allocated related to among others the interest expenses and costs on bond loans for an amount of 40.502 k EUR (2015: 43.854 k EUR). Furthermore, it was decided to use in 2016 the accumulated funds from allotments built up until 2014 (2015: 25.652 k EUR). The funds from allotments of 2015 are still recorded as deferred income and amount to 6.405 k EUR (2015: 7.161 k EUR).

Since the settlement of the solidarity related to the certificates for green energy can be both a receivable or a liability, this item must be read together with the item reported in the notes 'Trade and other receivables'.

The terms and the conditions for the debts are as follows:

For the standard trade debts the average payment term amounted to 39 days and for contractors 30 days after invoice date.

Debts for VAT and withholding tax are paid respectively 20 and 15 days after the end of the month. All debts are paid by the maturity date.

## 28. Current tax liabilities

(In thousands of EUR)	2016	2015
Tax expenses on current year result	124.271	122.605
Tax increase	0	739
Advances paid	-26.555	-16.020
Deductable withholding tax	-14	-114
<b>Tax expense current year</b>	<b>97.702</b>	<b>107.210</b>
<b>Tax expenses on previous years</b>	<b>104.564</b>	<b>268</b>
<b>Total tax expenses</b>	<b>202.266</b>	<b>107.478</b>

In January 2017, all taxes related to 2015 have been paid.

## Financial instruments

### 29. Financial instruments: policy

#### Risks

It is the Group's intention to understand all risks separately, as well as their mutual connections, and to define strategies in order to manage the economic impact on the Group's results. The Audit Committee is responsible for reviewing the risk analysis, for the approval of the recommended risk management strategies, and for compliance with the guidelines on risk management and reporting.

#### *Equity structure*

The Group's equity structure consists of equity and the financial liabilities.

Apart from the legally (Belgian) required minimum levels for equity that are applicable, the mission charged associations are also subject to the Flemish Decree on Intermunicipal Cooperation. This decree stipulates that by the end of 2018 at the latest no Private Partner / shareholder can participate in the share capital of mission charged associations (the principle of mixed mission charged associations companies will disappear). As from the amendment during 2016, this is again allowed for the sectors of energy and waste, provided that certain conditions are met. For the ex IGAO municipalities (in IMEA, Intergem and Iveka), Iveka and Intergem this date is earlier, being 31 December 2014, 31 December 2016 and 14 September 2018 respectively.

On 29 December 2014 the share of the private partner/participant Electrabel N.V. in equity (Belgian GAAP) was purchased by the public participants.

The purpose of the Group is to maintain a strong balance sheet structure and to ensure that the Group can retain a 'good' credit rating from the credit rating offices. Hence, the Group was preparing the participation of a private partner during 2016. The statutory structure required amendments to enable a merger of the seven DSOs in Eandis Assets. As not all conditions precedent of the transaction had been completed, the merger-company Eandis Assets could not be founded. Consequently, the private partner could not participate.

As the Group works within a regulated environment with a guaranteed remuneration (fair remuneration/profit and a guaranteed return/dividend), the risk is rather limited. During 2016 and 2015 the Group fulfilled all 'expected' obligations.

The Group has called upon long and short term funding to support its capital structure.

The Group monitors its solvency. Solvency means the degree to which the Group, in case of liquidation, can meet its financial obligations towards the providers of debt capital.

#### *Credit risk*

The credit risk comprises the risk that one party to a financial instrument will cause a financial loss for the other party by failing to discharge an obligation.

The Group pursues a credit policy whereby the credit risk is scrutinized and diversification of counterparties is necessary.

The maximum credit risk is each financial asset's balance sheet value.

Trade debtors  
Ageing analysis of trade receivables past due, but not impaired

(In thousands of EUR)	2016	2015
1 - 60 days	7.939	12.285
61 - 90 days	3.804	2.877
91 - 180 days	10.423	7.368
181 - 365 days	16.094	15.203
>365 days	18.817	20.101
<b>Total trade receivable - net</b>	<b>57.077</b>	<b>57.834</b>

Movements in accumulated impairments on trade receivables

(In thousands of EUR)	2016	2015
<b>Balance at 1 January</b>	<b>-75.761</b>	<b>-77.145</b>
Charge of impaired receivables	-7.643	-5.541
Write back of impaired receivables	7.350	6.925
<b>Total at 31 December</b>	<b>-76.054</b>	<b>-75.761</b>

*Currency risk*

The Group is not substantially exposed to currency risk since transactions in currencies other than the euro are limited.

*Liquidity risk*

The liquidity risk implies the risk that the Group will encounter difficulties in meeting its obligations associated with financial liabilities. The Group limits this risk by scrutinizing cash flows continually and by taking care that a sufficient number of credit facilities are available.

The Group can call upon several banks to attract resources on short term. It has the possibility to issue commercial paper within the framework of a treasury bill programme, to draw upon fixed advances with a maturity of one week up to twelve months and to take up straight loans with a maturity between one day up to one year. All loans have fixed interest rates except for the bank overdraft that has a variable interest rate.

The Group borrows on a long term basis mainly to finance its ongoing investments in the distribution grid for electricity and gas, and to refinance loans and pay interest. During 2014 the collected cash of these debentures was also used to pay the exit fee relating to Electrabel's exit from the DSOs' equity.

During 2010, the Group issued for the first time bond loans aimed at private investors in Belgium and the Grand Duchy of Luxembourg.

To diversify and broaden its funding resources, so that a safe, reliable, efficient, and innovative distribution of energy to the customers can be assured, Eandis has requested a rating from Moody's Investors Service ('Moody 's').

In October 2011, Moody's granted Eandis System Operator an 'A1' credit rating with a 'negative outlook.' This rating was confirmed by Moody's on 5 July 2016. On 14 December 2016, however, Moody's reviewed the rating to A3 (stable outlook) as the merger of the seven DSOs in Eandis Assets was not accomplished and so attracting a private partner for this merged company had to be stopped.

Eandis System Operator successfully issued bonds in the framework of its € 5 billion Euro Medium Term Note (EMTN) programme. There has always been a large interest from European investors for the bond issuances and also interest from private investors to whom several bond loans were issued.

In the framework of the € 5 billion EMTN programme an amount of € 2.660 million or 53,21 % was issued. As from 2014 onwards, no issues have taken place under this programme.

An overview of the loans is included in the note 'Interest bearing loans and borrowings'.

The following schedule shows the maturity schedule of the different loans.  
At the end of 2016

(In thousands of EUR)	2016	1 year or less	2-3 year	4-5 year	More than 5 year
Bond issue - retail	319.958	150.012	0	169.946	0
Bond issue - EMTN	2.642.164	0	0	498.821	2.143.343
Bond issue - private	435.042	0	0	0	435.042
Bank loans - fixed interest rate	1.494.381	131.521	273.457	218.749	870.654
Bank loans - variable interest rate	0	0	0	0	0
Bank loans - with derivative instrument	708.252	73.855	154.895	164.829	314.673
<b>Total</b>	<b>5.599.797</b>	<b>355.388</b>	<b>428.353</b>	<b>1.052.345</b>	<b>3.763.711</b>
<b>Total bullet payment</b>	<b>3.397.164</b>	<b>150.012</b>	<b>0</b>	<b>668.767</b>	<b>2.578.385</b>
<b>Total bullet payment excluded</b>	<b>2.202.633</b>	<b>205.376</b>	<b>428.353</b>	<b>383.578</b>	<b>1.185.327</b>

At the end of 2015

(In thousands of EUR)	2015	1 year or less	2-3 year	4-5 year	More than 5 year
Bond issue - retail	319.970	0	150.038	169.932	0
Bond issue - EMTN	2.639.987	0	0	0	2.639.987
Bond issue - private	434.803	0	0	0	434.803
Bank loans - fixed interest rate	1.761.385	667.004	215.675	197.763	680.944
Bank loans - variable interest rate	34	34	0	0	0
Bank loans - with derivative instrument	779.771	71.519	150.087	159.796	398.369
<b>Total</b>	<b>5.935.951</b>	<b>738.558</b>	<b>515.799</b>	<b>527.491</b>	<b>4.154.103</b>
<b>Total bullet payment</b>	<b>3.894.760</b>	<b>500.000</b>	<b>150.038</b>	<b>169.932</b>	<b>3.074.790</b>
<b>Total bullet payment excluded</b>	<b>2.041.191</b>	<b>238.558</b>	<b>365.762</b>	<b>357.559</b>	<b>1.079.313</b>

#### *Interest rate risk*

The Group has entered into long-term loans with a fixed and variable interest rate. Loans with variable interest were swapped to a fixed interest rate (see note 'Derivative financial instruments'). For certain loans, forward swap contract were concluded. All other loans were initially at a fixed interest rate.

The interest payment for the following years, calculated on the basis of the current interest rate, is as follows:

(In thousands of EUR)	2016	2015
In 2016	0	192.817
In 2017	161.412	156.404
In 2018	163.583	158.865
In 2019	149.726	145.301
In 2020	142.913	138.785
In 2021	129.907	126.079
In 2022 and beyond	662.662	637.221
<b>Total</b>	<b>1.410.204</b>	<b>1.555.472</b>

#### *Other*

More information about the risks of the Group and its shareholders is included in the prospectus of the Eandis System Operator group (Eandis System Operator cvba and its subsidiaries) dated 25 November 2014 concerning the guaranteed Euro Medium Term Note Programme and the investor presentation of January 2017. These documents can be consulted on the website [www.eandis.be](http://www.eandis.be).

## Fair value

The fair value is the amount for which an asset could be exchanged or a liability settled between knowledgeable, willing parties that are independent in an arm's length transaction and not in a forced sale or liquidation sale.

(In thousands of EUR)	Level 1	Level 2
Other investments	987	0
Green energy and cogeneration certificates (GEC & CGC)	546.107	0
Trade and other receivables excluding GEC and CGC	1.130.893	0
Cash and cash equivalents	2.708	0
<b>Total</b>	<b>1.680.695</b>	<b>0</b>
Loans on short term	411.309	0
Bond loans (included short term portion)	3.880.975	0
Loans on long term (included short term portion)	2.202.633	0
Derivative financial instruments	0	131.067
<b>Total</b>	<b>6.494.917</b>	<b>131.067</b>

### Fair value hierarchy

The Group uses the following fair value hierarchy classification to determine and classify the fair value of the financial instruments by a valuation technique:

Level 1: valuation is based on quoted (unadjusted) prices in an active market for identical assets or liabilities

Level 2: other techniques for which all input with a significant impact on the recorded fair value can be observed either directly or indirectly

Level 3: techniques that use input with a significant impact on the recorded fair value that is not based on observable market data.

The following methods and assumptions were used to estimate the fair values:

Cash and short term deposits, trade receivables (net of impairment), trade payables and other current liabilities approximate the carrying amounts as to the short term maturity of these instruments.

The fair value of the unquoted other investments is based on the latest available financial information.

The fair value of the certificates for green energy and cogeneration certificates are the guaranteed amount, as stipulated in the decision of the Flemish Government amending the Energy Decree. The fair value of the quoted bond loans is based on the price quotations at the reporting date.

The derivative financial instruments are interest rate swaps. The valuation techniques are swap models that use value calculations. The models include various kinds of input including forward prices, yield curves that are obtained on the basis of market interest rates and derivatives from market prices of various financial products that are requested with various market participants.

The fair value was obtained on the basis of the indicative quotations on Bloomberg (Bloomberg is a prominent provider of business and financial market news. On the reporting date it delivers world economic news, quotes for stock futures, stocks and other).





The fair value of the quoted bonds, issued for a total amount of 2.980,5 million EUR varies according to the market interest rate. The fair value at 31 December 2016 amounts to 3.441,0 million EUR and differs from the amount that will be reimbursed and the carrying value.

## Other information

### 30. Related parties

Transactions between the DSOs and their subsidiaries (the associated parties) have been eliminated in the consolidation process and are therefore not included in this note.

The remunerations paid to the directors are attendance fees and transport fees for an amount of 460.718,98 EUR in 2016 and 635.792.42 EUR in 2015.

The remunerations paid to the management committee and the directors amounted to 3.318.971,97 EUR for 2016 and 3.562.056,96 EUR for 2015. The post-employment benefits included in the total remuneration mentioned amounted for 2016 to 624.971,32 EUR and for 2015 to 786.435,55 EUR. There are no other benefits in kind, share options, credits or advances granted to the directors.

Transactions of the Group with companies with a non-controlling interest (Farys/TMVW during 2016 and 2015 and Ores Assets/Ores during 2015) were as follows:

(In thousands of EUR)	2016	2015
<b>Amount of the transactions</b>		
Recharge of costs to the non-controlling interests	4.804	10.220
Recharge of costs from the non-controlling interests	116	2.723
<b>Amount of outstanding balances</b>		
Trade receivables	605	1.460
Trade payables	3	250

Transactions of the Group with other companies (Atrias and Synductis) were as follows:

(In thousands of EUR)	2016	2015
<b>Amount of the transactions</b>		
Recharge of costs to other companies	2.330	2.323
Recharge of costs from other companies	7.654	5.823
<b>Amount of outstanding balances</b>		
Trade receivables (including financing)	16.478	11.270
Trade payables	2.745	1.251

#### *Membership of professional organisations*

Eandis System Operator is a member of Synergrid vzw, which is the Belgian common interest federation of the electricity and gas transport and distribution grid operators.

Eandis System Operator is a member of the European Distribution System Operators for Smart Grids (EDSO for Smart Grids).

During 2016 the parent companies, DSOs, paid fees of 58 k EUR to the statutory auditor and an amount of 20 k EUR for other assignments.  
The fee for other assignments was approved by the Audit Committee.

### 31. Contingencies

(In thousands of EUR)	2016	2015
Rent deposits, buildings	1.463	1.374
Other bank guarantees	484	11.114
Pledge trade receivables	11.349	0
<b>Guarantees given</b>	<b>13.297</b>	<b>12.488</b>
Guarantees obtained from contractors and suppliers	51.562	43.848
Goods held by third parties in their own name but at risk for the Group	49	45
Obligation to purchase property, plant and equipment	4.698	3.570
Obligation to sell property, plant and equipment	8.442	500
Obligation to rehabilitation	860	910

Outstanding orders in 2016 amounted to 21.132 k EUR (2015: 20.786 k EUR).

The Group has rented several buildings and adjoining parking lots for a total value of 6.016 k EUR in 2016 and 6.055k EUR in 2015, as well as cars for a total value of 4.798 k EUR in 2016 and 4.883 k EUR in 2015.

The future rent obligations (operational rent obligations) concern buildings, vehicles and other materials.

The contracts relating to buildings contain renewal clauses and have an average term of two years.

The future minimum lease payments under non-cancellable finance leases are as follows.

(In thousands of EUR)	2016
In 2017	8.768
In 2018 and 2019	10.462
In 2020 and 2021	3.655
In 2022 and beyond	918
<b>Total</b>	<b>23.803</b>

The Group's budgeted investments for 2017 were estimated at 446.481 k EUR (532.096 k EUR in 2016).

Furthermore, there is also a legal dispute pending between the DSOs and Essent concerning free distribution of green electricity (3.533 k EUR for 2016 and 2015), with Infrabel and the Flemish Region on grid displacements (5.526 k EUR in 2016 and 5.594 k EUR in 2015) and disputes with various parties (for a total of 9.281 k EUR in 2016 and 11.693 k EUR in 2015).

The Group is involved in legal disputes for which the risk of loss is possible but not likely and for which, as a result, no provisions have been set up. Currently, the possible timing of the settlements cannot be estimated reliably.

### **32. Events after the reporting date**

On 18 January 2017 the credit rating agency Creditreform Rating AG has granted Eandis System Operator a rating A+ with stable outlook.

Creditreform is a European rating agency of German origin and is recognized by the ESMA (European Security and Market Authority) since 2011. See press release on [www.eandis.be](http://www.eandis.be).

Eandis System Operator and Infracore will roll out digital meters together.

On 3 February 2017, the Flemish Government approved the introduction of digital meters on the grid. From 2019 onwards, these new, digital meters will be installed in various phases, initially in new constructions or at major renovation, or with specific customer groups, such as owners of solar panels and customers with a budget meter. Eandis System Operator and Infracore, the two Flemish network operators, are satisfied with this decision. They will actively participate in the stakeholder consultation planned by the Flemish Government to update the cost-benefit analysis of these digital meters. Afterwards, Eandis System Operator and Infracore will realize the harmonized roll out of the digital meters in Flanders in their joint venture company Fluvius.

On 27 March 2017 the press reported on some policy initiatives launched by the Flemish Energy Minister Tommelein on the future structure of the Flemish energy distribution sector and Eandis System Operator, and more in particular on an integration of the operating companies Eandis System Operator and Infracore. The Board of Directors of Eandis System Operator has taken notice of this and concludes that the ideas put forward by the minister are in line with Eandis' vision and the measures the company had already taken in the creation of Fluvius as a joint affiliate of Eandis System Operator and Infracore. Eandis System Operator is therefore looking forward to working together with the Flemish government on the future of the sector.

### 33. List of group entities included in the consolidation

Subsidiary	Registered office	Number of shares owned (%)	Voting rights (%)
<b>Distribution System Operators *</b>			
Gaselwest	President Kennedypark 12, B-8500 Kortrijk		
IMEA	Merksemsesteenweg 233, B-2100 Deurne		
Imewo	Brusselsesteenweg 199, B-9090 Melle		
Intergem	Administratief Centrum (AC), Franz Courtensstraat 11, B-9200 Dendermonde		
Iveka	Koningin Elisabethlei 38, B-2300 Turnhout		
Iverlek	Aarschotsesteenweg 58, B-3012 Wilsele-Leuven		
Sibelgas	Gemeentehuis St. Joost-Ten-Node, Sterrenkundelaan 12, B-1210 Brussels		
<b>Subsidiaries</b>			
Eandis System Operator cvba	Brusselsesteenweg 199, B-9090 Melle	100,00	100,00
De Stroomlijn cvba	Brusselsesteenweg 199, B-9090 Melle	64,03	64,03
Atrias cvba	Ravensteingalerij 4 bus 2, B-1000 Brussels	25,00	25,00
Synductis cvba	Brusselsesteenweg 199, B-9090 Melle	33,24	32,47
Warmte@Vlaanderen cvba	Boombekelaan 14, B-2660 Hoboken	50,00	50,00
Fluvius cvba	Koning Albert II laan 37, B-1030 Brussels	50,00	50,00

\* Address of contact: Brusselsesteenweg 199, B-9090 Melle

The subsidiaries Warmte@Vlaanderen and Fluvius were established during 2016 but do not contain any activity yet at the end of December 2016. They were registered in the consolidation as 'Investments in other companies'.

The company Eandis System Operator cvba together with its subsidiaries De Stroomlijn, Atrias, Synductis, Warmte@Vlaanderen and Fluvius form the (legal) 'Eandis System Operator group'. This group reports its IFRS results, which can be consulted on the website [www.eandis.be](http://www.eandis.be).

## Operating in a regulated environment

### 34. Operating in a regulated environment

#### Renewal of permission to call on the operating company

The Flemish energy regulator VREG has by its decision of 24 February 2015 granted the permission to the DSOs to call on the services of Eandis System Operator cvba as operating company for electricity. This authorisation applies as from 5 September 2014 and is valid for a period of twelve years.

#### Recognition of the distribution system operators

The Flemish energy regulator VREG reported, by letter of 6 February 2015, its decision of 3 February 2015 to renew the recognition of the 7 DSOs as electricity distribution system operators. This designation is valid for a period of 12 years starting from 5 September 2014.

On 29 September 2015 the VREG decided to renew the term for the 7 DSOs for gas distribution for a period of 12 years beginning on 14 October 2015. At the same time, the permission to operate with Eandis System Operator cvba as operating company for gas was granted.

#### Regulated tariff methodology

The Group operates in a regulated environment and hence revenue is based on tariff rates that were approved by the regulator.

As a result of the Sixth State Reform the VREG – Flemish Regulator of the electricity and gas markets - has as from **1 July 2014**, retrieved the competence of the federal regulator CREG to determine the tariff methodology for distribution in the Flemish region.

- **Tariff methodology 2015-2016**

On 30 September 2014 the VREG determined a new tariff rate methodology for electricity and gas for the DSOs active in the Flemish region for the regulatory period 2015-2016.

In building the new tariff method the following elements were taken into account: promoting efficient operations, information asymmetry, stability, transparency, administrative efficiency and avoiding rate volatility. This method should be an incentive for the DSOs to work in a cost-efficient and sustainable manner.

The costs are divided into three categories that also have another determination of its related income: The exogenous costs are the costs over which the DSO has no control because they are imposed: the cost of GEC, cogeneration certificates, premiums for RUE and social public service obligations; the non-exogenous costs include the cost of depreciation, the operational costs and the compensation for the cost of capital; and other costs include the fines.

The allowable income will be determined as follows: the income related to the exogenous costs is tailored to the exogenous costs; the income for the non-exogenous costs follows a stimulating revenue regulation to support efficient operations and the remaining costs are borne by the distribution system operator.

The capital remuneration is referred to by the VREG as the total of the average regulated assets at a stipulated cost of capital (4,8 % - gross 6,20 % as a result of the application of the corporate income tax) and the accepted net operating capital at a determined level (4,1 %) and an additional increase for the compensation for the cost of capital related to the exogenous costs at the legal interest rate of 2.25 %.

The recording of the exogenous costs at their actual value will give rise to differences between the rates and accounting costs. These balances should be booked on specific accounts and are named 'regulatory balance' in contrast to the differences from previous tariff methodologies that are named 'regulatory assets/liabilities'.

There are two regulatory balances allowed: a regulatory balance for exogenous costs and a regulatory balance for the volume differences regarding the revenue for non-exogenous costs.

#### **Regulatory assets/liabilities of the past**

The CREG has fixed the amounts of the regulatory assets/liabilities from the financial years 2008 and 2009. These may be recuperated in accordance with the amounts that were agreed upon by the VREG, being half of the amount in 2015 and the other half in 2016.

On 30 June 2015, the Brussels Court of Appeal ruled that the VREG is competent to determine the regulatory balances of the period 2010 to 2014 as well as their destination.

In its decision of 5 October 2015 the VREG ruled that for the time being 20% of the deficits of this period can be recharged in the tariffs of 2016.

#### **Eligible income 2015-2016**

The eligible income (fair remuneration) for the period 2015-2016 is made up of a portion related to the allowed income for exogenous costs and a portion for non-exogenous costs. There is a budget proposal submitted by the DSOs based on a reporting model.

The income related to the non-exogenous cost is determined on the basis of the evolution of the non-exogenous sector costs for a historical period of four years (2010-2013) which, according to a linear regression technique will determine the future income. Inflation is taken into account by discounting the costs to their current value. Also an annual adjustment for inflation is taken into account, based on the consumer price index (CPI) of August.

The data and information provided by the DSO in the reporting model regarding prior financial years, need to be controlled by the Auditor who needs to submit a report of factual findings (assurance report) to the VREG.

#### **Tariffs for 2015**

On 18 December 2014, the VREG approved the tariffs for the DSOs for 2015.

Eandis has asked for an adjustment on the proposed tariffs, because the federal contribution (decrease) and the Elia-tariff (increase) were changed after the submission. The VREG changed the tariffs accordingly as from 1 March 2015.

There was also a request for an adjustment to the tariffs following the transition from the legal entity tax to the **corporate income tax** of the DSOs. The adjustment of the rates will start from **1 August 2015** onwards. The amount not yet recovered of corporate income tax for the tax year 2015 was settled in 2016 on top of the corporation tax for the tax year 2016.

A further change concerns the increase of the VAT rate for electricity as from 1 September 2015.

#### **Approved tariffs for 2016**

On 14 December 2015 the VREG published the distribution tariffs for electricity and gas.

The main changes concern the **provisional recharge of 20 %** of the accumulated deficit (regulatory transfer) from the period 2010-2014, the abolishment of the **100 kWh free electricity** and the full globalization in Flanders of the cost of green energy by also removing the ceiling that was used in the past for the settlement.

The accumulated balances related to the **Federal contribution** - charges to finance funds held by the CREG - must be recorded on the balance sheet and will be settled as soon as a decision is taken by the CREG (federal matter).

#### **Adjustments to the tariff methodology of 2016**

On **28 June 2016** the VREG reviewed the existing tariff methodology 2015-2016 as a result of the introduction of the public service obligation of the distribution system operators to stimulate the **infrastructure for electric vehicles**. This tariff methodology does not affect the distribution tariffs. The costs and benefits of the operation will be followed up during 10 years and then settled.

- **Tariff methodology 2017-2020**

On 24 August 2016, the VREG published the tariff methodology for the Flemish electricity and natural gas distribution system operators for the period 2017-2020.

The tariff methodology includes among others

- Adjustments to the parameters for the remuneration for cost of capital: net working capital is compensated to the corrected WACC before corporate income tax (5,00%), equity to 5,24%, the cost of debt capital to 3,04%
- Further recuperation of the regulatory assets/liabilities for the period 2010-2014 over 5 years (until 2020)
- the new regulatory balances can be recuperated according to an annual percentage of cumulated balance: exogenous costs (60%), volume differences 75 % (electricity) and 40% (gas), corporate income tax (for the part via endogenous costs), indexing of endogenous cost 50 %
- There will be reports on the quality of service (Q-factor): for example power cuts and intervention time for connectivity. The financial settlement will take place via a bonus or malus starting from the next regulatory period. During this tariff period the DSOs only need to report to the regulator.

### Eligible income 2017

On 7 October 2016, the VREG established the permitted income for the natural gas and electricity distribution system operators for 2017. The distribution rates were determined on the basis of the tariff methodology 2017-2020. For both gas and electricity, there is an increase compared to 2016 mainly due to the increasing costs for the GEC (electricity) and the processing of the regulatory balances.

### Tariffs for 2017

On 20 December 2016, the VREG approved the distribution tariffs for electricity and gas for the year 2017. The rates for electricity rise because of the increased costs on which the distribution system operator does have any impact (GEC and RUE contributions).

### Accounting treatment

Overview of the assets and liabilities of the settlement mechanism (see note 'Trade and other receivables' and 'Trade and other short-term liabilities').

(In thousands of EUR)	2016	2015
Transfers 2008 - 2009	-2.006	53.888
Transfers 2010 - 2014	266.551	345.372
<b>Total regulatory assets*</b>	<b>264.545</b>	<b>399.260</b>
<b>Regulatory balances</b>		
Balances from 2015	268.275	259.705
Balances from 2016	54.414	0
<b>Total regulatory balances</b>	<b>322.689</b>	<b>259.705</b>
<b>Total amount recoverable</b>	<b>587.234</b>	<b>658.965</b>
of which reported as Current assets	587.234	658.965



\* Transfers were grouped according to their recuperation in the tariffs with 50,00 % take back of the transfers recorded in 2008 and 2009 to recuperate during 2015 and 2016 (with the exception of the transfer for the Walloon municipalities) and 20 % take back of the transfers recorded in 2010 up to and including 2014 to recuperate during 2016 (with the exception of the scheme for the Walloon municipalities and separate treatment of the federal contribution amounting to 63.417 k EUR).

Reconciliation of the settlement mechanism.

(In thousands of EUR)	2016	2015
Regulatory assets at 1 January	658.965	452.986
Recovered transfers from 2008 - 2009	-55.894	-53.726
Recovered transfers from 2010 - 2014	-78.821	0
Transfer to third parties	113	0
<b>Total movements regulatory assets*</b>	<b>-134.602</b>	<b>-53.726</b>
Additional transfer from 2015	8.432	259.705
Additional transfer from 2016	54.414	0
<b>Total movements regulatory balances</b>	<b>62.846</b>	<b>259.705</b>
<b>Total movements</b>	<b>-71.756</b>	<b>205.979</b>
Movement through the income statement	-71.756	205.979
Transfer to third parties	25	0
<b>Regulatory assets at 31 December</b>	<b>587.234</b>	<b>658.965</b>

With regard to the transfers, being the differences between the actual and the budgeted costs and revenues and the settlement mechanism, the regulatory assets and the related calculations still need to obtain approval by the CREG/VREG, notwithstanding the control of the reporting for the year 2014. This uncertainty comprises that the control by the regulator can give rise to additional differences that need to be processed as an adjustment to the regulatory assets/liabilities or via the result in the following financial year.

Up till now, Eandis has not yet received a final decision from the regulator on the reporting of the results of 2010 up to 2015. The VREG has meanwhile started the control on the balances of 2010-2014 (which, in principle, will be completed by the end of 2017). In the meantime, already 20% of the regulatory transfers in relation to the period 2010-2014 was recovered in 2016 for the first time.

At the moment there are no specific IFRS guidelines as to the accounting treatment of the settlement mechanism in a regulated environment.

On 30 January 2014 the IASB published a new standard IFRS14 Regulatory Deferral Accounts. This new standard is applicable for "first time adopters" and allows the recording of regulated assets and liabilities as separate items of the balance sheet and profit and loss account. This standard was not endorsed by the EU and is awaiting the final standard.

Free translation from the Dutch original

## **Statutory auditor's report to the shareholders of the Flemish distribution net owners on the consolidated financial statements of the Economical Group Eandis as of and for the year ended 31 December 2016**

We report to you on the performance of our mandate which was assigned to us by the Management Committee of Eandis System Operator CVBA. This report includes our opinion of the financial position as at 31 December 2016, the consolidated statement of the realized and non-realized results, the consolidated statement of changes in equity and the consolidated statement of cash flows for the year for the year ended 31 December 2016 and the notes (all elements together "the Consolidated Financial Statements"). The consolidated financial statements of the Economical Group Eandis consists of seven Flemish Distribution System Operators (DSOs): Gaselwest, IMEA, Imewo, Intergem, Iveka, Iverlek and Sibelgas who have joint control over Eandis System Operator CVBA and its subsidiaries (De Stroomlijn CVBA, Synductis CVBA, Atrias CVBA, Fluvius CVBA and Warmte@Vlaanderen CVBA).

### **Report on the Consolidated Financial Statements - Unqualified opinion**

We have audited the Consolidated Financial Statements of the Economical Group Eandis (together "the Group") as of and for the year ended 31 December 2016, prepared in accordance with the *International Financial Reporting Standards* as adopted by the European Union, which show a consolidated balance sheet total of € 9.617.821 thousand and of which the consolidated income statement shows a profit for the year of € 282.892 thousand.

### *Responsibility of the Management Committee of Eandis System Operator CVBA for the preparation of the Consolidated Financial Statements*

The Management Committee of Eandis System Operator CVBA is responsible for the preparation of Consolidated Financial Statements that give a true and fair view in accordance with the *International Financial Reporting Standards* as adopted by the European Union. This responsibility includes: designing, implementing and maintaining internal control relevant to the preparation of Consolidated Financial Statements that give a true and fair view and that are free from material misstatement, whether due to fraud or error; selecting and applying appropriate accounting policies; and making accounting estimates that are reasonable in the given circumstances.

### *Responsibility of the statutory auditor*

Our responsibility is to express an opinion on these Consolidated Financial Statements based on our audit. We conducted our audit in accordance with International Standards on Auditing ("ISAs"). Those standards require that we comply with the ethical requirements and plan and perform the audit to obtain reasonable assurance about whether the Consolidated Financial Statements are free from material misstatement.

**Audit report dated 29 March 2017 on the Consolidated Financial Statements  
of the Economical Group Eandis as of and  
for the year ended 31 December 2016 (continued)**

An audit involves performing procedures to obtain audit evidence about the amounts and disclosures in the Consolidated Financial Statements. The procedures selected depend on the statutory auditor's judgment, including the assessment of the risks of material misstatement of the Consolidated Financial Statements, whether due to fraud or error. In making those risk assessments, the statutory auditor considers internal control relevant to the Group's preparation and presentation of the Consolidated Financial Statements that give a true and fair view, in order to design audit procedures that are appropriate in the circumstances, but not for the purpose of expressing an opinion on the effectiveness of the Group's internal control. An audit also includes evaluating the appropriateness of accounting policies used, the reasonableness of accounting estimates made by the Management Committee, as well as evaluating the overall presentation of the Consolidated Financial Statements.

We have obtained from the Management Committee and the Company's officials the explanations and information necessary for performing our audit procedure and we believe that the audit evidence we have obtained is sufficient and appropriate to provide a basis for our opinion.

*Unqualified opinion*

In our opinion, the Consolidated Financial Statements of the Group as at 31 December 2016 give a true and fair view of the consolidated net equity and financial position, as well as its consolidated results and its consolidated cash flows for the year then ended in accordance with the International Financial Reporting Standards as adopted by the European Union.

*Emphasis of matter paragraph*

Without qualifying our opinion, we wish to draw the attention to the information, included in note 34 of the Consolidated Financial Statements related to operating in a regulated environment, which clarifies the specificities of the regulatory framework, tariffs and related accounting treatment. The information also clarifies the uncertainties related to the financial balances resulting from tariff settlement mechanisms which are still to be approved by the VREG.

Ghent, 29 March 2017

Ernst & Young Bedrijfsrevisoren BCVBA  
Statutory auditor  
represented by



Paul Eelen  
Partner

**ANNEX 3**  
**CONSOLIDATED FINANCIAL STATEMENTS EANDIS ECONOMIC GROUP AS OF AND**  
**FOR THE FINANCIAL YEAR ENDED 31 DECEMBER 2015**



**Economic Group Eandis**

**Consolidated Financial Statements IFRS**

**Year end 31 December 2015**

## Content

### Consolidated Financial Statements

**Consolidated statement of profit or loss**

**Consolidated statement of comprehensive income**

**Consolidated statement of financial position**

**Consolidated statement of changes in equity**

**Consolidated statement of cash flows**

**Notes to the consolidated financial statements**

1. Reporting entity
2. Summary of significant accounting policies
  - 2.1. Statement of compliance and basis of presentation
  - 2.2. Principles of consolidation
  - 2.3. Segment information
  - 2.4. Significant accounting policies
  - 2.5. Summary of changes in accounting policies
  - 2.6. Use of estimates and judgments
  - 2.7. Standards issued but not yet effective
3. Operating revenue
4. Cost of trade goods
5. Cost for services and other consumables
6. Employee benefit expenses
7. Amortization, depreciation, impairments and changes in provisions
8. Other operational expenses
9. Regulated transfers
10. Financial results
11. Income tax expenses
12. Intangible assets
13. Property, plant and equipment
14. Investments in associates
15. Other investments
16. Long term receivables
17. Inventories
18. Trade and other receivables
19. Cash and cash equivalents
20. Share capital and reserves
21. Interest bearing loans and borrowings
22. Pensions and other post-employment employment benefit plans
23. Derivative financial instruments
24. Provisions, other
25. Government grants
26. Trade payables and other liabilities
27. Current tax liabilities
28. Financial instruments: risks and fair value
29. Related parties
30. Commitments and contingencies
31. Events after the reporting date
32. List of group entities included in the consolidation

**Operating in a regulated environment**

# Consolidated Financial Statements

## Consolidated statement of profit or loss

(In thousands of EUR)	Notes	2015	2014
<b>Operating revenue</b>	<b>3</b>	<b>2.677.762</b>	<b>2.781.007</b>
Revenue		2.315.718	2.148.647
Other operating income		59.116	86.052
Own construction, capitalized		302.928	546.308
<b>Operating expenses</b>		<b>-2.065.689</b>	<b>-2.299.725</b>
Cost of trade goods	4	-1.025.983	-1.006.921
Cost for services and other consumables	5	-488.053	-635.823
Employee benefit expenses	6	-368.472	-383.343
Depreciation, amortization, impairments and changes in provisions	7	-333.272	-315.221
Other operational expenses	8	-55.888	-60.412
Regulated balances and transfers	8	205.979	101.995
<b>Result from operations</b>		<b>612.073</b>	<b>481.282</b>
Finance income	10	27.011	4.857
Finance costs	10	-211.874	-257.837
<b>Profit before tax</b>		<b>427.210</b>	<b>228.302</b>
<b>Income tax expenses</b>	<b>11</b>	<b>-142.767</b>	<b>188.737</b>
<b>Profit for the period</b>		<b>284.443</b>	<b>417.039</b>

## Consolidated statement of comprehensive income

(In thousands of EUR)	Notes	2015	2014
<b>Profit for the period</b>		<b>284.443</b>	<b>417.039</b>
<b>Other comprehensive income</b>			
<b>Items not to be reclassified to profit or loss in subsequent periods</b>			
Actuarial gains (losses) on long term employee benefits	22	51.003	-38.824
Deferred tax gains (losses)*	11	-2.929	-507.038
<b>Net other comprehensive income not being reclassified to profit or loss in subsequent periods</b>		<b>48.074</b>	<b>-545.862</b>
<b>Total comprehensive income for the period</b>		<b>332.517</b>	<b>-128.823</b>

\* As from 2015 the Distribution System Operators are subject to corporate tax and as a result deferred tax was calculated as from the year 2014. This calculation has important effects on the different elements of equity. See note 'Income tax expenses'.



## Consolidated statement of financial position

(In thousands of EUR)	Notes	2015	2014
<b>Non-current assets</b>		<b>7.908.256</b>	<b>7.854.706</b>
Intangible assets	12	105.586	106.559
Property, plant and equipment	13	7.800.585	7.745.624
Investments in an associate	14	11	5
Other investments	15	919	1.092
Long term receivables	16	1.155	1.426
<b>Current assets</b>		<b>1.814.932</b>	<b>2.306.126</b>
Inventories	17	45.316	34.199
Trade and other receivables	18	1.765.960	2.263.014
Cash and cash equivalents	19	3.656	8.913
<b>TOTAL ASSETS</b>		<b>9.723.188</b>	<b>10.160.832</b>
<b>EQUITY</b>	<b>20</b>	<b>1.977.198</b>	<b>2.608.370</b>
<b>Total equity attributable to owners of the parent</b>		<b>1.976.119</b>	<b>2.607.291</b>
Capital		1.278.688	2.056.752
Reserves		759.548	679.802
Other components of equity		-651.430	-699.505
Retained earnings		589.313	570.241
<b>Non-controlling interest</b>		<b>1.079</b>	<b>1.079</b>
<b>LIABILITIES</b>		<b>7.745.990</b>	<b>7.552.462</b>
<b>Non-current liabilities</b>		<b>6.027.245</b>	<b>6.463.752</b>
Interest bearing loans and borrowings	21	5.197.393	5.533.554
Employee benefit liability	22	331.250	425.074
Derivative financial instruments	23	145.715	169.839
Provisions	24	18.027	20.476
Other non-current liabilities		0	2.285
Deferred tax liabilities	11	334.860	312.524
<b>Current liabilities</b>		<b>1.718.745</b>	<b>1.088.710</b>
Interest bearing loans and borrowings	21	963.796	516.126
Government grants	25	0	0
Trade payables and other current liabilities	26	647.471	569.464
Current tax liabilities	27	107.478	3.120
<b>TOTAL EQUITY AND LIABILITIES</b>		<b>9.723.188</b>	<b>10.160.832</b>

## Consolidated statement of changes in equity

(In thousands of EUR)	Share Capital	Reserves	Other comprehensive income	Retained earnings	Total equity attributable to equity holders	Non-controlling interest	Total
<b>Balance at 1 January 2014</b>	<b>1.924.415</b>	<b>520.437</b>	<b>-153.643</b>	<b>687.087</b>	<b>2.978.296</b>	<b>1.079</b>	<b>2.979.375</b>
Total comprehensive income for the period	0	0	-38.824	417.039	<b>378.215</b>	0	<b>378.215</b>
Transition to corporate tax	0	0	-507.038	0	<b>-507.038</b>	0	<b>-507.038</b>
Share capital decrease	-51.981	0	0	0	<b>-51.981</b>	0	<b>-51.981</b>
Share capital increase	184.318	-6.076	0	-178.242	<b>0</b>	0	<b>0</b>
Addition/decrease reserves	0	165.441	0	-165.441	<b>0</b>	0	<b>0</b>
Dividends paid	0	0	0	-190.202	<b>-190.202</b>	0	<b>-190.202</b>
<b>Balance at 31 December 2014</b>	<b>2.056.752</b>	<b>679.802</b>	<b>-699.505</b>	<b>570.241</b>	<b>2.607.291</b>	<b>1.079</b>	<b>2.608.370</b>
Total comprehensive income for the period	0	0	48.075	284.443	<b>332.518</b>	0	<b>332.518</b>
Share capital decrease	-895.798	0	0	0	<b>-895.798</b>	0	<b>-895.798</b>
Share capital increase	117.734	0	0	0	<b>117.734</b>	0	<b>117.734</b>
Addition/decrease reserves	0	79.746	0	-79.746	<b>0</b>	0	<b>0</b>
Dividends paid	0	0	0	-185.625	<b>-185.625</b>	0	<b>-185.625</b>
<b>Balance at 31 December 2015</b>	<b>1.278.688</b>	<b>759.548</b>	<b>-651.430</b>	<b>589.313</b>	<b>1.976.119</b>	<b>1.079</b>	<b>1.977.198</b>

The above information is disclosed in the notes 'Equity' and as regard to 'other comprehensive income' in the notes 'Income tax expenses' and 'Employee benefit liabilities'.

## Consolidated statement of cash flows

(In thousands of EUR)	Notes	2015	2014
Profit for the period		284.443	417.039
Amortization of intangible assets	7, 12	44.264	45.598
Depreciation on property, plant and equipment	7, 13	292.841	287.550
Change in provisions (Reversal -; Recognition +)	7, 24	-2.450	-4.257
Impairment current assets (Reversal -; Recognition +)	7	-1.383	-13.670
Gains or losses on realization receivables		11.690	24.195
Net finance costs	10	208.989	204.826
Change in fair value of derivative financial instruments	10	-24.125	48.380
Gains or losses on sale of property, plant and equipment		40.308	32.280
Movement in government grants	25	0	-226
Income tax expense	11	142.767	-188.737
<b>Operating cash flow before change in working capital and provisions for employee benefits</b>		<b>997.344</b>	<b>852.978</b>
Change in inventories	17	-11.117	-2.191
Change in trade and other receivables		486.697	-996.509
Change in trade payables and other current liabilities		80.447	36.227
Change in employee benefits		-42.821	-33.098
<b>Net operating cash flow</b>		<b>513.206</b>	<b>-995.571</b>
Interest paid		-211.917	-195.254
Interest received		2.306	3.458
Financial discount on debts	10	673	854
Income tax paid		-19.002	-3.194
<b>Net cash flow from operating activities</b>		<b>1.282.610</b>	<b>-336.729</b>
Proceeds from sale of property, plant and equipment		3.091	2.336
Purchase of intangible assets	12	-43.291	-44.953
Purchase of property, plant and equipment	13	-391.201	-453.926
Net investments		0	-104
Proceeds from sale of other investments	15	387	0
Net investments in long term receivables		9	-22
<b>Net cash flow used in investing activities</b>		<b>-431.005</b>	<b>-496.669</b>
Proceeds from issue of shares	20	117.734	0
Repayment of share capital	20	-895.798	-51.981
Repayment of borrowings	21	-516.126	-269.223
Proceeds from borrowings	21	400.000	300.000
Proceeds from bonds/borrowings	21	0	1.274.998
Change in current liabilities	21	225.238	-226.317
Transfer of guarantee for allotments	26	-2.285	0
Dividends paid	20	-185.625	-190.202
<b>Net cash flow from/used in financing activities</b>		<b>-856.862</b>	<b>837.275</b>
<b>Net increase/decrease in cash</b>	<b>20</b>	<b>-5.257</b>	<b>3.877</b>
<b>Cash and cash equivalents at the beginning of period</b>		<b>8.913</b>	<b>5.036</b>
<b>Cash and cash equivalents at the end of period</b>		<b>3.656</b>	<b>8.913</b>

# Notes to the consolidated financial statements

## 1. Reporting entity

The consolidated financial statements of the Economic Group Eandis comprise – beside the accounts of the 7 Flemish Distribution System Operators (DSOs) Gaselwest, IMEA, Imewo, Intergem, Iveka, Iverlek and Sibelgas – the accounts of the subsidiaries being the operating company Eandis cvba, and its subsidiaries De Stroomlijn cvba, Indexis cvba, Atrias cvba and SYNDUCTIS cvba. The aggregated accounts taken together form the ‘Economic Group’.

The DSOs are being managed centrally by their operating company Eandis.

The statutory aim of the DSOs is the distribution system operation as understood by the Flemish Energy Decree and their execution resolutions, as well as carrying out each peripheral activity, such as public lighting.

The main activities are subject to the regulation by the Flemish Regulator of Electricity and Gas (VREG). For more information, see chapter ‘Operating in a regulated environment’.

The Group can also carry out other activities such as energy services to local authorities (ESLA). At request of the local public authorities (municipalities, cities, ...) Eandis offers support at cost price aiming at planning and implementing efficient measures and projects for energy saving and energy efficiency.

During 2014, the development, construction and operation of district heating grids and the delivery of heat was added to the portfolio of services.

The companies IMEA, Imewo, Intergem, Iveka and Iverlek are mission charged associations according to the provisions of the Flemish Decree on Intermunicipal Cooperation (6 July 2001). Until recently, the companies Gaselwest and Sibelgas were intermunicipal associations under the form of cooperative societies with limited liability. On 1 January 2015, the legal status of the company Gaselwest was converted to a mission charged association to comply as much as possible with the articles of association of the other Flemish DSOs (Decree of 25 April 2014 – on cross-border intermunicipal companies) and on 30 June 2015 the same adoption took place for Sibelgas.

Electrabel, the private partner of the DSOs, sold its shares in the DSOs on 29 December 2014. All of these shares were purchased by the DSOs’ public shareholders.

As from 2015 onwards, the DSOs are no longer subject to legal entity tax but to corporate income tax. This change has an impact on the shareholders’ equity and profit as deferred taxes were recognized in 2014.

All companies of the Group are registered in Belgium.

In October 2011 the rating agency Moody’s Investors Service (‘Moody’s’) granted Eandis an ‘A1’ credit rating (negative outlook) which was confirmed on 10 September 2015. The rating allows Eandis to issue bonds in the international financial markets.

Eandis cvba was active in 234 cities and municipalities and employed, together with its subsidiaries, on average 4.480 persons during 2015.

## **2. Summary of significant accounting policies**

### **2.1. Statement of compliance and basis of presentation**

The consolidated financial statements have been prepared in accordance with International Financial Reporting Standards (IFRS), as published by the International Accounting Standard Board (IASB) and endorsed by the European Community on 31 December 2015. The Group has not applied new IFRS requirements that are effective after 2015.

The consolidated financial statements are expressed in thousands of euro, which is the functional currency and presentation currency of the Group. They have been prepared with the assumption that business activities will be continued and under the historical cost convention method unless otherwise stated.

### **2.2 Principles of consolidation**

The consolidated financial statements comprise all subsidiaries over which the Group has control. There is control when the Group has the power to govern the financial and operating policies of the entity so as to obtain benefits from its activities. Such a form of control exists when the companies, directly or indirectly, hold more than half of the voting rights in the entity. The existence and impact of potential voting rights that were exercisable or convertible at that time, are being taken into consideration when judging whether the Group has the control to determine the financial and operating policies of another entity.

Subsidiaries have been fully consolidated as of the date on which the Group gained actual control until the date the Group no longer exercises such control.

The financial reporting of the subsidiaries is prepared for the same reporting year as that of the parent companies, using consistent accounting principles. All intercompany transactions, balances and unrealized gains and losses between group companies have been eliminated.

Non-controlling interest in the net assets of the consolidated subsidiaries has been individually reported in equity of the parent companies. Non-controlling interest consists of the amount of that interest at the acquisition date and the non-controlling share in the equity changes since the date of the business combination. Losses relative to the minority that are higher than the non-controlling interests in the subsidiary's equity have been allocated to the Group's interests with the exception of those cases in which the minority has a binding obligation to make additional investments to compensate for the losses and is able to do so.

A list of the subsidiaries of the Group is set out in note 'List of group entities included in the consolidation'.

### **2.3 Segment information**

The Group does not distinguish between different segments, neither at the level of activities, nor geographically, since the Group generates income from a sole activity, i.e. distribution network management (electricity and gas) in Flanders.

## 2.4 Significant accounting policies

As from 1 January 2015 a new accounting system was introduced. The reporting model was adopted to adhere to new structures (being future proof). Certain transactions, previously recorded in the DSOs, are now recorded in Eandis, such as billing to customers (excluding social suppliers), all transactions regarding green energy (green energy certificates and cogeneration certificates), application of the VAT-unit in Eandis and the application of customized allocations. These changes have an impact on the valuation of certain items of the balance sheet and shifts on line items of the profit and loss account compared to 2014.

As a consequence of the introduction of a section 'assets under construction' (as part of the property, plant and equipment), the valuation rules have been refined. Likewise, the accounting principles have been adopted to be in accordance with the Belgian tax rules as the DSOs are subject to corporate income tax starting from 2015.

The impact of these adjustments concerns mainly the depreciation of property, plant & equipment and trade receivables which is described in the corresponding notes.

The applied accounting policies are in accordance with last year's accounting principles subject to the extension for the above mentioned transactions.

### a) Operating income

#### *Goods sold and services rendered*

Revenue from sale of goods has been recognized when all of the following conditions have been satisfied: the Group transferred the significant risks and rewards of ownership of the goods to the buyer; the Group retains neither the continuing managerial involvement nor effective control over the goods sold; the amount of revenue can be determined reliably; it is probable that the economic benefits associated with the transaction will flow to the Group; and costs incurred or to be incurred in respect of the transaction can be measured reliably.

On the basis of the previously mentioned principles the sale of goods and the rendering of services have been recognized at the moment of delivery of the goods to the customer, of the customer accepting the goods and of the collectability of the related amounts.

#### *Distribution network remuneration (energy transport) – Social function (energy supply)*

The distribution grid revenue (grid fee) is based on the actual billing of the grid fee of the DSOs in the relevant year.

The billing of grid fee to energy suppliers and other DSOs is based on the approved tariffs that are published on the websites of the respective DSOs. The real grid fee invoice contains invoiced advances (for customers whose meter is recorded annually), settlement billing (from annually recorded, manual monthly recorded and remotely read access points) as well as rectification invoices recorded in the calendar year concerned.

*Interest income* is recorded as soon as acquired and for the period to which it relates (taking into account the asset's actual interest rate), unless there is doubt about its collectability.

*Dividends received* are recognized in the income statement at the moment they are granted.

*Government grants* are recognized in the balance sheet as soon as it is reasonably certain that the grant will be received and that all of the conditions attached to it will be complied with.

Grants related to an asset are included in Government grants and will be recognized in the income statement on a systematic basis over the expected useful life of the related asset.

Grants related to expenses are presented in the income statement as Other operating income in the same period in which the costs are included.

## b) Expenses

*The finance costs* include interest on loans, calculated using the effective interest rate method and bank charges. All interest and other costs incurred in connection with loans or other financial transactions such as hedging options are recognized as financial expenses when they occur.

The *taxes on profit or loss* for the financial year include the current and deferred taxes. The tax on profit of the year is recorded in the profit and loss accounts unless they relate to transactions that were recorded directly in equity. In this case, the taxes are directly charged to equity.

The current tax expenses are the expected current taxes payable on the taxable income for the year, based on tax rates in effect at the balance sheet date and any adjustment to current taxes payable from previous years. For the calculation of the income tax on the taxable income for the year, the current tax rate (that has been enacted or substantively enacted by the end of the reporting period) is used.

Deferred taxes are recognized for temporary differences between the tax values of assets and liabilities and the carrying amounts for financial reporting purposes.

Until the end of 2014 the DSOs are only subject to legal entity tax on the portion of the dividend granted to the private partner/participant (Electrabel N.V.). As from 2015 onwards, the DSOs will have to pay corporate tax, as well as Eandis and its subsidiaries.

## c) Intangible assets

Intangible assets are measured at cost less any accumulated amortizations and possible impairment losses.

Costs relating to research, which is carried out with the purpose of obtaining new technical knowledge and insights, are recognized in the income statement in the period in which they occur.

Costs relating to the development phase, in which knowledge obtained through research is applied in order to achieve a plan or design for the production of new or significantly improved products and processes, are included in the balance sheet if and only if the product or process was technically and commercially feasible, the entity has the necessary resources to complete the development, it is probable that future economic benefits will flow into the Group and the cost can be measured reliably. The capitalised amount includes all costs that are directly attributable to the creation, production, and the preparation of the asset, so that it could operate in the same manner as intended by the management.

Intangible assets with a finite useful life are amortized on a straight-line basis over their expected useful life. Another amortization method is only used if the expected pattern of consumption of the future economic benefits of the asset was better reflected.

Intangible assets are not revalued.

When the carrying amount of an intangible asset exceeds its recoverable amount, the asset is considered impaired and is written down to its recoverable amount.

The following amortization percentages are used in the calculation of depreciation:

Software	20,00 %
Cost for smart projects, clearing house and district heating	20,00 %

## d) Property, plant and equipment

Property, plant and equipment are measured at historical cost less third party contributions, the accumulated depreciations and impairment losses. The historical cost comprises the initial purchase price plus other directly attributable costs.

The cost price of assets of own-production comprises the cost of material, direct labour cost and a reasonable part of indirect labour costs. These indirect labour costs comprise that part of general administrative and operational costs that cannot be directly attributed to investment expenses. These costs (for the largest part personnel costs) are added to the cost price of investment projects according to the internal billing system.

Each part of an item of property, plant and equipment with a cost that is significant in relation to the total cost of the item can be depreciated separately.

The Group recognizes the cost of an expansion or replacement part of such asset when these costs have been incurred if it is probable that the future economic benefits associated to that asset will flow to the Group and the asset's cost can be measured reliably. All other costs are expensed as incurred.

As from 2015 the costs of the networks not yet completed are classified as 'Assets under construction'. The investments reported are not depreciated.

Until 2014, depreciation is recognized in profit or loss on a straight-line basis as of the date of bringing into use and over the estimated useful life of each component of an item of property, plant and equipment.

As from 2015 the DSOs are subject to corporate income tax and the depreciation is calculated, in accordance with the tax rules, on a pro rata temporis basis during the year in which the asset is brought into use. This means that depreciation starts from the month after the month of bringing the asset into use.

Land is not depreciated. The applied depreciation percentages on the basis of the average useful life are as follows.

Construction and administrative buildings *	2,00 %
Networks and lines	2,00 %
Other distribution installations	3,00 %
Technical installations buildings*	4,00 %
Recycled equipment	6,67 %
Optical fibre	10,00 %
Electronic metering equipment	10,00 %
Office furniture and tools	10,00 %
Leasehold improvements*	10,00 %
Leasehold improvements – rented buildings*	11,12 %
Vehicles	20,00 %
Electronics in administrative buildings	20,00 %
Hardware	33,33 %
Test equipment EVA (Electric vehicles in action)	50,00 %

\* The depreciation rates indicated with an asterisk were used from fiscal year 2014 for the newly acquired investments

In the opening balance sheet as per 1 January 2007 the Belgian GAAP carrying amount, as accepted by the CREG, was taken as the opening value for IFRS.

Repair and maintenance costs that do not increase the future economic benefits, are recognized in the income statement as incurred.

Recognition of costs in the carrying amount of an item of property, plant and equipment ceases when the asset is at its location and in the condition necessary for it to function in the manner intended by management.



#### *Gains and losses on sale*

Any gain or loss arising on a sale of property, plant and equipment is included in the income statement. They are recognized when the significant risks and rewards of ownership have been transferred to the buyer, collectability of the consideration is probable, the associated costs can be estimated reliably, and there is no continuing managerial involvement with the property, plant and equipment.

#### *Leasing*

Lease of assets under which all the risks and rewards incidental to ownership are substantially retained by the lessor, are classified as operating lease.

Lease payments based on operating leases are expensed on a straight-line basis, unless another systematic method is more representative of the time pattern of the benefits for the user.

#### *Impairment*

The Group assesses at each reporting date whether there is an indication that an asset may be impaired. If any indication exists, the Group estimates the asset's recoverable amount.

Impairment has been recognized if an asset's carrying amount exceeds the recoverable value. Impairment is charged directly to the income statement.

#### e) Investments

All investments are accounted for at trade date.

Investments in equity instruments consist of interests in entities in which the Group does not have significant influence or control. This is the case in companies where the Group has less than 20% of the voting rights. Such investments are designated as financial assets available for sale and are at initial recognition measured at fair value unless the fair value cannot be reliably determined in which case they are measured at cost.

An impairment is recognized if the carrying amount exceeds the expected realizable value.

Options and warrants for the purchase of shares have been recognized at fair value. The fair value for the options and warrants was determined using the Black-Scholes model. Changes in fair value have been recognized in profit or loss.

#### f) Inventories

Inventories have been measured at purchase cost. Their value has been determined using the moving weighted average method.

An impairment is carried out on inventories if, due to its obsolescence, it is no longer usable or if its carrying amount exceeds the estimated sales price. If items of inventory have not been used for more than one year, an impairment of 100 % is recorded.

This impairment loss is recognized as an expense in the income statement.

#### g) Trade and other receivables

Trade and other receivables are measured at amortized cost.

An allowance for doubtful debt is recognized if the collection of the receivable becomes doubtful and after comparison with the realizable value.

In the case of a bankruptcy or judicial reorganization the receivable is immediately impaired and the value added tax recovered, on the basis of a certificate obtained from the curator or a publication of the closing of the bankruptcy in the annex to the Belgian Official Gazette.

In the framework of the full liberalization of the energy market in Flanders as per 1 July 2003, an impairment loss was recognized for the total amount including VAT of all receivables as per 31

December 2003, older than 6 months. These provisions have been reversed in view of the collection of these receivables or they have been used whenever these receivables have been written off.

The receivable of the work carried out and delivered services, with the exception of, on the one hand, the damages handled by the legal department and, on the other hand, the receivables from the affiliated municipalities, which are overdue for more than 6 months are recognized as doubtful and therefore impaired at 100% (excluding VAT).

A provision for bad debt related to receivables from energy supplies by the Distribution System Operators is calculated and recorded on the basis of the average collection degree stemming from statistical data of the payment history that was kept since the liberalisation of the energy market for the main client categories.

Receivables are permanently impaired (written off) using the provision for bad debts that was set up for this purpose as soon as certificates, provided by bailiffs, lawyers or debt collection agencies can demonstrate that there is no recoverability possible.

Also when it can be revealed that the revenue associated with a possible recovery does not compensate (i.e. not economically justifies) the costs for this recovery, the receivable is completely impaired using the provision which was set up for this purpose.

#### h) Cash and cash equivalents

Cash and cash equivalents comprise the readily available cash resources, deposits that can be immediately withdrawn and other short term, highly liquid investments (with a maximum maturity of three months), that are readily convertible to known amounts of cash and which are subject to an insignificant risk of changes in value. They are stated at face value, which approximates their fair value. For the purpose of the cash flow statement, they are presented as cash and cash equivalents.

#### i) Share capital

Up to the beginning of 2015, the share capital is represented by certificates C, shares A, C, D without nominal value and F and the shares/certificates E" and E. Together with the shares/certificates C, they are entitled to a dividend.

The shares A, C, D and F have voting rights; the certificates C, the shares/certificates E" and E do not have voting rights.

The profit is paid proportionally to the shares A or C and the certificates C after setting up the necessary reserves and after paying the remuneration for the F shares and the shares/certificates E" and E according to the reimbursement rate stipulated in the articles of association.

During 2015 the shares F and the shares/certificates E" and E were converted to shares A.

The shares A and C are entitled to a dividend.

The shares A and C have voting rights, the certificates C have no voting rights.

Dividends are recognized as a liability in the period in which they have been approved.

If there are components of the results that are the consequence of elements originating in the captive period (before 1 July 2003) and that would have affected the outcome of the relevant period, then this part of the result is assigned to the participants according to the terms as were applicable with respect to the distribution of net profit realized in the years preceding the first effects of liberalization.

#### j) Loans and borrowings

Interest bearing loans are recognized initially at fair value less related transaction costs. Subsequent to initial recognition, interest bearing loans are measured at amortized cost, in which

any difference between the proceeds and the reimbursement is charged to the income statement using the effective interest method over the maturity of the loans.

#### k) Employee benefit liability

##### *Pension plans and other post-employment benefits*

The contributions for defined contribution plans have been recognized as an expense at the moment when incurred including possible deficits to the minimum guaranteed return. These pension plans are subject to the Act of 28 April 2003 regarding additional pensions and the tax regime of these pensions and of some additional social security benefits (the 'W.A.P./L.P.C.'). According to Article 24 of this Act, the Group has to guarantee an average minimum return of 3,75 % on employee contributions and of 3,25 % on employer contributions.

Starting from 2016 the guaranteed yield will be adapted as a consequence of a change in the law (see note 'Pensions and other post-employment benefit plans').

These kinds of pension plans are valued by using the intrinsic value. Any individual difference between the mathematical reserve and the minimum guaranteed amount will be recorded as a liability in the financial statements.

The Group's liabilities for the defined benefit plans, as well as for the subsequent costs, have been valued on the basis of the 'Projected Unit Credit' method. The amount recognized in the balance sheet represents the present value of the pension liabilities (Defined Benefit Obligation) mentioned, less the fair value of plan assets.

Remeasurements comprise actuarial gains and losses, and the return on plan assets (excluding interest) which is reflected in the statement of financial position with a charge or credit recognized in other comprehensive income in the period in which they occur. Remeasurements are not reclassified to profit or loss in subsequent periods.

Past service costs are recognized in profit or loss in the period of a plan amendment.

Net interest is calculated by applying the discount rate at the beginning of the period to the net defined benefit liability.

The amounts recognized in the income statement comprise service costs (including current service costs, past service costs, gains and losses on other long term employee benefits as well as curtailments and settlements), net interest expense or income and remeasurement.

The Group presents the first two components of the defined benefit costs in profit or loss on the line item Employee benefit expenses.

##### *Other long term employee benefits contain provisions for retirement and jubilee bonuses.*

These benefits are treated in the same manner as pension plans; however, past service costs and actuarial gains and losses have immediately been recognized in the income statement.

All pension liabilities are valued on an annual basis by a qualified actuary.

#### l) Derivative financial instruments

The Group uses derivative financial instruments (Linear Constant Maturity Swap – LCMS; Interest Rate Swaps - IRS and other) to hedge the exposure to interest rate risks that arise from its financing activities. Derivative financial instruments are initially recognized at fair value. The gain or loss resulting from fluctuations in the fair value is immediately accounted for through the income statement. The fair value of the interest rate swaps was the estimated amount the Group would receive or pay to end the swap at the balance sheet date, taking into account the actual interest rate and the creditworthiness of the counterparty.

The derivatives do not qualify for hedge accounting.

m) Provisions, other

Provisions are recognized in the balance sheet when the Group has a present (legal or constructive) obligation as a result of a past event, and when it is probable that an outflow of financial resources will be required to settle the obligation and the obligation's amount can be reliably estimated.

The amount recognized as provision is the best available estimate on the balance sheet date for the expenses needed to meet the existing liabilities, possibly discounted if the money's time value is relevant.

n) Trade and other liabilities

Trade and other liabilities have been measured at amortized cost.

o) Income tax expense

Current tax assets and liabilities are offset only if the entity has a legally enforceable right to set off the recognized amounts and has the intention to either settle the obligation on a net basis, or to realize the asset and settle the liability simultaneously.

The deferred tax assets and liabilities reflect the deductible or taxable temporary differences between the carrying amounts and the tax values.

The deferred tax assets and liabilities are measured at the tax rates that are expected to be applied in the period in which the claim will be realized or the obligation will be met, using the tax rates that have been enacted or substantively enacted by the end of the reporting period.

The deferred tax assets are recorded when it is probable that taxable profits will be realized to settle the deferred tax.

## 2.5 Summary of the new accounting standards applicable as from 2015

The following standards, interpretations and amendments are applicable for the accounting period beginning on 1 January 2015. As required, those adjustments on the accounting policies are detailed below.

- Improvements to IFRS (2011-2013), applicable for annual periods beginning on or after 1 January 2015
- IFRIC 21 *Levies*, applicable for annual periods beginning on or after 17 June 2014

## 2.6 Use of estimates and judgments

The preparation of the consolidated financial statements in conformity with IFRS requires management to make judgments, estimates and assumptions that might affect the reported amounts of assets and liabilities, and the amounts of revenue and expenses. The estimates and the underlying assumptions have been based on past experience and several other factors that are believed to be reasonable given the circumstances. The results thereof form the basis for the judgment on the carrying amount of assets and liabilities that could not be deduced in a simple way from other sources. The actual results could differ from these estimates.

The estimates and underlying assumptions are reviewed on an ongoing basis. Revisions to accounting estimates are recognized in the period in which the estimate is revised if the revision affects only that period or in the period of the revision and the future periods if the revision affects both current and future periods.

#### *Defined benefit plans and other long term employee benefits*

The cost of the defined benefit pension plans and other long term employee benefits and the present value of the pension obligation are determined using actuarial valuations. This involves making various assumptions that may differ from actual developments in the future.

Due to the complexity of the actuarial calculations and the long-term nature of the obligation, the defined benefit obligation is highly sensitive to changes in the assumptions.

The major assumptions and a sensitivity analysis are disclosed in the note 'Pensions and other post-employment benefit plans'.

#### *Derivative financial instruments*

Information about major items of uncertainty and critical judgment with regard to the recording of the derivative financial instruments is included in the note 'Financial instruments: risks and fair value'.

## **2.7 Standards issued but not yet effective**

The following new standards and interpretations were published, but were not yet applicable for the annual period beginning on 1 January 2015.

- IFRS 9 *Financial Instruments* and subsequent amendments, applicable for annual periods beginning on or after 1 January 2018 but not yet endorsed by the EU  
This standard was issued in the framework of a wider project to replace IAS 39. IFRS 9 prevents but simplifies the mixed valuation model and suggests two primary valuation classes for financial assets: amortized cost and fair value.
- Amendments to IFRS 10, IFRS 12 and IAS 28 *Investment Entities: Applying the Consolidation Exception*, effective 1 January 2016 but not yet endorsed by the EU
- Amendments to IFRS 10 *Consolidated Financial Statements* and IAS 28 *Investments in Associates and Joint Ventures - Sale or Contribution of Assets between an Investor and its Associate or Joint Venture*, effective 1 January 2016 but not yet endorsed by the EU
- Amendments to IFRS 11 *Joint Arrangements – Accounting for Acquisitions of Interests in Joint Operations*, effective 1 January 2016
- IFRS 14 *Regulatory Deferral Accounts*, effective 1 January 2016 but not yet endorsed by the EU  
IFRS 14 is an optional standard that allows an entity whose activities are subject to rate-regulation, to continue applying most of its existing accounting policies for regulatory deferral account balances upon its first-time adoption of IFRS. Entities that adopt IFRS 14 must present the regulatory deferral accounts as separate line items on the statement of financial position and present movements in these account balances as separate line items in the statement of profit or loss and other comprehensive income. The standard requires disclosures on the nature of, and risks associated with, the entity's rate-regulation and the effects of that rate-regulation on its financial statements.
- IFRS 15 *Revenue from Contracts with Customers*, effective 1 January 2018 but not yet endorsed by the EU  
IFRS 15 establishes a new five-step model that will apply to revenue arising from contracts with customers. Under IFRS 15 revenue is recognised at an amount that reflects the consideration to which an entity expects to be entitled in exchange for transferring goods or

services to a customer. The principles in IFRS 15 provide a more structured approach to measuring and recognising revenue.

- Amendments to IAS 1 *Presentation of Financial Statements* – Disclosure Initiative, effective 1 January 2016 but not yet endorsed by the EU
- Amendments to IAS 16 *Property, Plant and Equipment* and IAS 38 *Intangible Assets* – Clarification of Acceptable Methods of Depreciation and Amortization, effective 1 January 2016
- Amendments to IAS 16 *Property, Plant and Equipment* and IAS 41 *Agriculture* – Bearer Plants, effective 1 January 2016
- Amendments to IAS 19 *Employee Benefits* – Defined Benefit Plans: Employee Contributions, effective 1 February 2015
- Amendments to IAS 27 *Separate Financial Statements* – Equity Method in Separate Financial Statements, effective 1 January 2016 but not yet endorsed by the EU
- Annual Improvements to IFRSs - 2010-2012 Cycle (Issued December 2013), effective 1 February 2015
- Annual Improvements to IFRSs - 2012-2014 Cycle (Issued September 2014), effective 1 January 2016 but not yet endorsed by the EU

The Group will apply the new standards and interpretations applicable to its financial statements as soon as they become effective. The Group has not opted for early application of these standards and interpretations.

The adoption of these standards, interpretations and amendments to the standards already issued and their impact on the Group's results are currently being assessed.

### 3. Operating revenue

#### Revenue

(In thousands of EUR)	2015	2014
Distribution and transport grid revenue	2.182.494	2.014.244
Sale of energy	72.579	68.963
Construction works for third parties	60.645	59.665
Other sales	0	5.775
<b>Total</b>	<b>2.315.718</b>	<b>2.148.647</b>

The Group has realized most of its revenue from the remuneration of the distribution and transport of electricity and gas via its networks. This revenue should be evaluated together with the regulatory transfers. The increase in distribution and transmission grid fee is due to the new tariff methodology of the VREG, which was applied as from 1 January 2015 and the additional adjustments to these tariffs during the year (see chapter 'Working in a regulated environment').

The sale of energy consists of the energy supplies to individuals who do not find an energy supplier on the market due to payment problems.

The billing of construction works for third parties comprises the construction works carried out by Eandis (possibly in synergy with other utilities) for the account of customers.

The other sales mainly comprise the revenue from costs billed for studies, combined heat and power projects and others. This item is being reported as 'Other operating income - recuperations' as from 2015 and amounts to 5.097 k EUR.

#### Other operating income

(In thousands of EUR)	2015	2014
Recuperations	44.170	72.433
Other	14.946	13.619
<b>Other operating income</b>	<b>59.116</b>	<b>86.052</b>
<b>Own construction, capitalized</b>	<b>302.928</b>	<b>546.308</b>

The recuperations relate to billings for work performed for customers, the re-invoicing of costs for RUE campaigns and the recovery of general expenses by contractors, insurance and other authorities. During 2015 an amount of 1.537 k EUR was received from the Natural Gas Fund (Aardgasfonds) (2014: 46.330 k EUR).

The other operating income mainly comprises allowances for damages and operations, gains on trade receivables (207 k EUR in 2015 and 224 k EUR for 2014) and gains on the sale of property, plant and equipment (2.189 k EUR in 2015 and 986 k EUR for 2014).

All costs related to distribution activities have been registered as operational cost. Periodically, a settlement has been recorded and certain costs related to investments have been activated through the item Own construction, capitalized. As a result, this revenue cannot be considered as an operating income.

The decline of this item during 2015 is the consequence of the changes in the accounting system, whereby for specific costs (mainly costs for services and other consumables) a direct allocation (netting) was recorded. The remainder that could not be assigned, has therefore decreased and is still recorded via the former procedure and included as an Own construction, capitalized.

This item also contains the contributions received from customers (103.275 k EUR for 2015 and 103.463 k EUR for 2014) which are also deducted as own construction, capitalized (-103.275 k EUR for 2015 and -103.463 k EUR for 2014).

#### 4. Cost of trade goods

(In thousands of EUR)	2015	2014
Cost for transportation	455.715	440.576
Purchase of energy	30.030	28.833
Purchase of goods for resale	79.785	102.425
Purchase of grid losses	16.859	34.306
Certificates for green energy	443.594	400.781
<b>Total</b>	<b>1.025.983</b>	<b>1.006.921</b>

The **cost for transportation** includes the expense of the federal contribution amounting to € 61,2 million for 2015 (59,5 million for 2014). This contribution is used to finance certain public service obligations, the obligations for denuclearization, the reduction of emissions of greenhouse gases (Kyoto) and the costs relating to the regulation and control of the energy market. The DSOs charge these costs in their tariffs to the end users, through the suppliers i.e. a cascade mechanism (see note 'Operating revenue').

The Group has the obligation to buy **certificates for green energy** that were offered at a certain price. These certificates can be sold in an active market. The value of the certificates sold is lower than the purchase price. The resulting costs were included under the heading 'Certificates for green energy' as well as the revaluation cost to fair value and the solidarity contribution on the certificates for green energy (see note Trade and other receivables ).



## 5. Cost for services and other consumables

(In thousands of EUR)	2015	2014
Cost of purchase network grids	71.120	240.895
Cost for direct purchases	30.113	34.839
Fee for usage of installations	45.117	35.482
Advertising, information, documentation, receptions a.o.	9.320	12.604
Subsidy for rational use of energy (RUE)	72.820	54.318
Contribution 100 kWh free of charge	150.214	100.962
Contracts and administration costs	1.582	7.395
Consultancy and other services	56.394	94.883
Other	51.373	54.445
<b>Total</b>	<b>488.053</b>	<b>635.823</b>

The cost for services and other consumables decreased with 147.770 k EUR compared to 2014. This decrease is mainly due to lower costs of purchase of network grids (169.775 k EUR) due to changes in the accounting system and for these costs a netting can be carried out. On the other hand, the premiums for the rational use of energy (18.502 k EUR) and the contribution for 100 kWh free of charge (49.252 k EUR) increased. The latter cease to exist at the end of 2015 and, as a result all the advances were recorded in 2015 (see chapter 'Working in a regulated environment').

The item 'Other' comprises the costs for rent, communication, transport, insurance and other.

## 6. Employee benefit expenses

(In thousands of EUR)	2015	2014
Remunerations	258.746	262.230
Social security contributions	71.752	72.642
Contributions to defined benefit plans and other insurances	21.666	32.210
Other personnel costs	16.308	16.261
<b>Total</b>	<b>368.472</b>	<b>383.343</b>

The employee benefit expenses amounted to 368.472 k EUR in 2015, a decrease of 14.871 k EUR compared to 2014, mainly as a result of the decrease in the contribution for pension plans and insurances.

The average number of employees amounted to 4.480 persons in 2015 and 4.645 persons in 2014.

## 7. Amortization, depreciation, impairments and changes in provisions

(In thousands of EUR)	2015	2014
Amortization of intangible assets	44.264	45.598
Depreciation of property, plant and equipment	292.841	287.550
<b>Total amortization and depreciation</b>	<b>337.105</b>	<b>333.148</b>
Impairment of inventories and trade receivables	-1.383	-13.670
Changes in provisions	-2.450	-4.257
<b>Total</b>	<b>333.272</b>	<b>315.221</b>

The amortization and depreciation amount to 337.105 k EUR at the end of 2015, an increase of 3.957 k EUR mainly as a result of depreciation of property, plant and equipment.

From 2015 the distribution system operators are subject to corporate income tax and hence the depreciation is calculated, in accordance with the Belgian tax rule, on a "pro rata temporis" basis during the year in which the asset is taken into service.

Also, networks for which the work is still in progress, are now reported in a separate category "Assets under construction" and are not depreciated.

Both measures have a beneficial effect on the total amount of depreciation: 5.188 k EUR lower amortisation for the intangible assets and 9.233 k EUR lower depreciation for the property, plant & equipment.

The impairment of trade receivables mainly concerns the use in 2014 of the provisions for doubtful receivables and overdue receivables (see note 'Financial instruments: risks and fair value - credit risk').

From 2015 onwards, the calculation of the provision for doubtful debts is based on statistical data obtained from the payment pattern of this category of clients (social suppliers). The impact of this adopted methodology on this category of clients is an extra cost of 2.885 k EUR.

The change in **provisions** mainly concerns the provision for rehabilitation costs which amounted to 2.192 k EUR in 2015 and 4.258 k EUR in 2014 (see note 'Provisions, other'). The decrease of the provisions was due to the use (rehabilitation and sale of land) and more specific elements which could reduce the provision of the rehabilitation cost.

## 8. Other operational expenses

(In thousands of EUR)	2015	2014
Loss on disposal/retirement of property, plant and equipment	42.506	33.267
Loss on realization receivables	11.897	24.419
Other	1.485	2.726
<b>Total</b>	<b>55.888</b>	<b>60.412</b>

## 9. Regulated balances and transfers

Since 2011 the Group reports the additions, recoveries and regularisation for transfers in this separate section as 'Operating expenses', where previously they were reported as 'Revenue'. The Group believes that the balance between actual income and expenses and the budgeted income and expenses is not part of revenue, since the recovery through tariffs will occur in a subsequent period.

The regulated balances and transfers for 2015 and 2014 are as follows:

(In thousands of EUR)	2015	2014
Addition regulated transfers	0	-101.995
Recuperation regulated transfers	53.726	0
Addition regulated balances	-259.705	0
<b>Total</b>	<b>-205.979</b>	<b>-101.995</b>

The revenue of the items 'Addition and recuperation transfers' relate to the additional revenue registration that is allowed as the difference between the actual income and expenses and the budgeted income and expenses as approved by the regulator. The result thus additionally reported will be recuperated through the tariffs of the following years (see chapter 'Operating in a regulated environment').

The additions of 2015 concern the regulatory balances (new terminology of the VREG) and consist of 218.001 k EUR exogenous expenses that may be charged to future tariffs and 41.704 k EUR non-exogenous costs (volume differences).

## 10. Financial results

(In thousands of EUR)	2015	2014
Interest income, banks	104	1.697
Interest income, derivative financial instruments	24.125	0
Other financial income	2.782	3.160
<b>Finance income</b>	<b>27.011</b>	<b>4.857</b>
Interest expenses, non-current loans	-200.922	-193.092
Interest expenses, current loans and other borrowings	-2.362	-1.678
Interest expenses, derivative financial instruments	0	-48.380
Other financial expenses	-8.590	-14.687
<b>Finance costs</b>	<b>-211.874</b>	<b>-257.837</b>

**Financial income** increases with 24.125 k EUR due to fair value adjustment of the derivative financial instruments which reported a loss in 2014 (see Financial expenses).

The other financial income contains mainly interest received from cash deposits, financial discounts received and income in 2014 from government grants.

The **interest expenses** on non-current and current loans increase with 8.514 k EUR in comparison to 2014.

The other financial expenses decrease with 6.097 k EUR compared to 2014 mainly due to the lower interest expenses on the defined benefit pension plans. Others items recorded in this item are incurred costs for loans and various bank costs.

## 11. Income tax

(In thousands of EUR)	2015	2014
Tax expenses on current year result	-122.605	-5.796
Tax expenses on previous year result	-15	19
Tax increase	-739	0
Deferred tax gains (losses)	-19.408	194.514
<b>Total income tax expenses</b>	<b>-142.767</b>	<b>188.737</b>

(In thousands of EUR)	2015	2014
Profit before tax	336.708	228.301
Theoretical tax rate (1)	114.447	77.600
Specific tax regime DSOs (2)	0	-76.185
	114.447	1.415
Effect non-deductable expenses	19.871	6.905
Effect deductible expenses	-11.713	-4.138
Usage of fiscal loss carried forward	0	0
Private entity tax DSOs on dividends for the private partner/shareholder	0	1.614
<b>Total income tax expenses</b>	<b>122.605</b>	<b>5.796</b>

(1) Subject to the legal Belgian tax rate of 33,99 %

(2) Up to 2014, the DSOs were only taxable on the amount that is allocated as a dividend to their Private Partner/shareholder for the gas activity. This dividend tax is calculated at 25,75 %.

#### Deferred taxes

Based on the Programme Act of 19 December 2014, the DSOs are subject to the corporate income tax of 33,99 % as from accounting year 2015. Since this law was enacted in 2014, deferred taxes on temporary differences between the tax values of assets and liabilities and their carrying amounts for financial reporting purposes are to be recorded in accordance with the application of IAS12 Income tax.

The calculation of deferred taxes has an important effect on the different components of the Group's equity.

Based on the Programme Act of 10 August 2015 it was clarified that the recorded provisions for liabilities and charges could be considered as having been already taxed (taxed reserve). Therefore, an amendment was made compared to the calculation of 2015 for this item.

The deferred taxes are a result of the following items and trigger the following movements on the balance sheet, the income statement and equity:

(In thousands of EUR)	2015	2014
Property, plant & equipment	-558.704	-572.457
Derivative financial instruments	49.364	57.579
Employee benefit liabilities	170.692	202.889
Provisions, rehabilitation	1.617	1.776
Provisions, other	2.171	-2.311
<b>Net deferred tax asset/(liability)</b>	<b>-334.860</b>	<b>-312.524</b>

	2015	2015	2014	2014
(In thousands of EUR)	Movements via P&L	Movements via OCI	Movements via P&L	Movements via OCI
Property, plant & equipment		13.753		-572.457
Derivative financial instruments	-8.215		57.579	
Employee benefit liabilities	-15.515	-16.682	137.470	65.420
Provisions, rehabilitation	-159		1.776	
Provisions, other	4.482		-2.311	
<b>Deferred tax benefit/(expense)</b>	<b>-19.408</b>	<b>-2.929</b>	<b>194.514</b>	<b>-507.038</b>
<b>Net movement during the year</b>	<b>-22.337</b>		<b>-312.524</b>	

The main temporary differences relate to the revaluation of property, plant & equipment and the provisions for pensions and other post-employment benefits. A deferred tax liability was recorded of 558.704 k EUR (572.457 k EUR in 2014) related to the revaluation of property, plant & equipment since, according to the Belgian tax law, the costs are not deductible. Concerning the pension and other post-employment benefit provision, the costs will be deductible according to the Belgian tax law, and therefore a deferred tax asset was recorded of 170.692 k EUR (202.889 k EUR in 2014).

(In thousands of EUR)	2015	2014
Deferred tax asset	223.843	262.245
Deferred tax liability	-556.533	-574.768
<b>Deferred tax liability, net</b>	<b>-334.860</b>	<b>-312.524</b>

The movements in the item deferred tax liability are as follows:

(In thousands of EUR)	2015	2014
<b>As per 1 January, 2014</b>	<b>-312.524</b>	<b>0</b>
Tax income/(expense) recognised in profit or loss	-19.408	194.514
Tax income/(expense) recognised in OCI of the previous periods	-2.929	-507.038
<b>As per 31 December 2014</b>	<b>-334.860</b>	<b>-312.524</b>

## 12. Intangible assets

(In thousands of EUR)	Licences and similar rights	Research costs	Total
Acquisition value at 1 January 2015	19.958	230.527	250.485
Acquisitions	333	42.958	43.291
Other	-15.546	0	-15.546
<b>Acquisition value at 31 December 2015</b>	<b>4.745</b>	<b>273.485</b>	<b>278.230</b>
Amortization and impairment at 1 January 2015	18.608	125.318	143.926
Amortization	478	43.786	44.264
Other	-15.546	0	-15.546
<b>Amortization and impairment at 31 December 2015</b>	<b>3.540</b>	<b>169.104</b>	<b>172.644</b>
<b>Net book value at 31 December 2015</b>	<b>1.205</b>	<b>104.381</b>	<b>105.586</b>

(In thousands of EUR)	Licences and similar rights	Development costs	Total
Acquisition value at 1 January 2014	19.470	186.062	205.532
Acquisitions	1.310	44.465	45.775
Other	-822	0	-822
<b>Acquisition value at 31 December 2014</b>	<b>19.958</b>	<b>230.527</b>	<b>250.485</b>
Amortization on and impairment at 1 January 2014	17.879	80.449	98.328
Amortization	729	44.869	45.598
<b>Amortization and impairment at 31 December 2014</b>	<b>18.608</b>	<b>125.318</b>	<b>143.926</b>
<b>Net book value at 31 December 2014</b>	<b>1.350</b>	<b>105.209</b>	<b>106.559</b>

The investments for the projects smart metering, smart grids, smart users (as from 2012) and district heating (as from 2014) are recorded as 'Development costs'. The acquisitions for the project smart metering amounted to 9.97 k EUR for 2015 and 14.695 k EUR for 2014.

No research costs are included in the income statement for 2015 and 2014.

There were no intangible assets with an indefinite useful life.

### 13. Property, plant and equipment

(In thousands of EUR)	Land and buildings	Installation, machinery and equipment	Furniture and vehicles	Others	Assets under construction	Total
Acquisition value at 1 January, 2015	260.992	12.657.106	397.202	19.062	3.738	13.338.100
Acquisitions	7.249	213.522	10.554	23	160.880	392.228
Sales and disposals	-1.847	-177.776	-52.506	0	0	-232.129
Transfer to others	4.567	169.025	-170.018	0	-3.574	0
<b>Acquisition value at 31 December, 2015</b>	<b>270.961</b>	<b>12.861.877</b>	<b>185.232</b>	<b>19.085</b>	<b>161.044</b>	<b>13.498.199</b>
Depreciation and impairment at 1 January, 2015	90.749	5.141.245	343.864	16.618	0	5.592.476
Depreciation	3.948	278.106	8.977	1.810	0	292.841
Acquisitions from third parties	680	2	345	0	0	1.027
Sales and disposals	-1.335	-135.142	-52.253	0	0	-188.730
Transfer to others	412	138.553	-138.965	0	0	0
<b>Depreciation and impairment at 31 December, 2015</b>	<b>94.454</b>	<b>5.422.764</b>	<b>161.968</b>	<b>18.428</b>	<b>0</b>	<b>5.697.614</b>
<b>Net book value at 31 December, 2015</b>	<b>176.507</b>	<b>7.439.113</b>	<b>23.264</b>	<b>657</b>	<b>161.044</b>	<b>7.800.585</b>

(In thousands of EUR)	Land and buildings	Installation, machinery and equipment	Furniture and vehicles	Others	Assets under construction	Total
Acquisition value at 1 January, 2014	242.024	12.385.696	387.783	17.711	0	13.033.214
Acquisitions	21.749	426.079	15.158	223	3.738	466.947
Sales and disposals	-1.629	-154.693	-5.739	0	0	-162.061
Transfer to others	-1.152	24		1.128	0	0
<b>Acquisition value at 31 December, 2014</b>	<b>260.992</b>	<b>12.657.106</b>	<b>397.202</b>	<b>19.062</b>	<b>3.738</b>	<b>13.338.100</b>
Depreciation and impairment at 1 January, 2014	74.931	5.001.121	329.382	13.916	0	5.419.350
Depreciation	4.007	261.227	19.703	2.613	0	287.550
Acquisitions from third parties	12.769	61	188	0	0	13.018
Sales and disposals	-845	-121.188	-5.409	0	0	-127.442
Transfer to others	-113	24	0	89	0	0
<b>Depreciation and impairment at 31 December, 2014</b>	<b>90.749</b>	<b>5.141.245</b>	<b>343.864</b>	<b>16.618</b>	<b>0</b>	<b>5.592.476</b>
<b>Net book value at 31 December, 2014</b>	<b>170.243</b>	<b>7.515.861</b>	<b>53.338</b>	<b>2.444</b>	<b>3.738</b>	<b>7.745.624</b>



The acquisitions reported in the item 'Installations, machinery and equipment' mainly relate to the investments in mid and low voltage electricity networks for a total value of 167.615 k EUR in 2015 and 227.963 k EUR in 2014 and investments in gas pipe lines and gas connections for a value of 111.582 k EUR in 2015 and 144.751 k EUR in 2014.

The commitments for the acquisition of property, plant and equipment at the end of 2015 amounted to 3.570 k EUR and 2.767 k EUR at the end of 2014. A commitment to sell property, plant and equipment for 500 k EUR existed at the end of 2015.

The net book value includes the assets paid by clients (third party intervention) and corresponds to the fair value of the Group's network.

As per 31 December 2015 and 2014, there are no restrictions on title and property, plant and equipment serving as pledge for liabilities.

## 14. Investment in an associate

The investments in associates increase from 5 k EUR at the end of 2014 to 11 k euros at the end of 2015. These investments are held in Atrias cvba and in Synductis cvba.

On 9 May 2011 **Atrias** cvba was established as a joint initiative of Belgium's five largest distribution system operators Eandis, Infrac, Ores, Sibelga and RESA.

Atrias is a central clearing house for the Distribution System Operators and charged with the development of a Message Implementation Guide (MIG), the development of a clearing house application, and the management and maintenance of this application.

MIG describes how the communication flow between the various players of the energy market should happen.

The Group has acquired 25 % of the shares. The amount of 5 k EUR was recorded as an investment in an associate.

Atrias is an unlisted company and has no official price quotation.

The following table summarizes the financial information of Atrias at 31 December:

(In thousands of EUR)	2015	2014
Property, plant and equipment	17.592	5.147
Current assets	7.940	7.451
Liabilities	25.513	12.579
Equity	19	19
<b>Share in equity</b>	<b>5</b>	<b>5</b>
Revenue	6.504	5.754
Result for the period	0	0
<b>Share in the result for the period</b>	<b>0</b>	<b>0</b>

**Synductis** cvba was founded on 21 December 2012 and aims to coordinate the infrastructure works by various utility companies in the Flemish cities and municipalities and so reduce nuisance of the works.

The various utility companies participating are: Eandis (distribution of gas and electricity), Farys/TMVW (Tussengemeentelijke Maatschappij der Vlaanderen voor Watervoorziening), IWVA (Intercommunale Waterleidingsmaatschappij van Veurne-Ambacht), IWVB (Intercommunale voor Waterbedeling in Vlaams-Brabant), Proximus (telecommunication) and Pidpa (Provinciale Intercommunale Drinkwatermaatschappij der Provincie Antwerpen).

The Group holds still 33,28 % of the shares since the step-in of Proximus, in early 2015. As from then, the amount of 6 k EUR was recorded as an investment in an associate.

Synductis is an unlisted company and has no official price quotation.

The following table summarizes the financial information of Synductis at 31 December:

(In thousands of EUR)	2015	2014
Property, plant and equipment	149	181
Current assets	727	1.029
Liabilities	857	1.191
Equity	19	19
<b>Share in equity</b>	<b>6</b>	<b>10</b>
Revenue	1.997	1.834
Result for the period	0	0
<b>Share in the result for the period</b>	<b>0</b>	<b>0</b>

The Group receives its share of the operating costs of Atrias and Synductis.

Since these companies also work at cost price, their results are without any profit or loss.

The Group grants funding and provides housing (see note 'Related parties').

## 15. Other investments

(In thousands of EUR)	2015	2014
Business centres	919	969
Other	0	123
<b>Total</b>	<b>919</b>	<b>1.092</b>

The other investments decrease from 1.092 k EUR at the end of 2014 to 919 k EUR at the end of 2015 as a result of the following transactions:

A sales agreement was signed on 11 November 2014, whereby Eandis cvba sold its shares of 10 k EUR in KIC InnoEnergy at 31 December 2014 at the latest, but effective on 14 February 2015.

The sales price amounts to 137 k EUR.

The company IICK was dissolved (the participation amounted to 104 k EUR as acquired in 2014) and on 9 December 2015 the Business Centre Westhoek was sold (the participation amounted to 50 k EUR).

The profit resulting from the above transactions amounts to 220 k EUR and has been included in the financial income (see note 'Financial results').

Furthermore, the participation of Eandis in Synductis for an amount of 9 k EUR was no longer included under this heading since the share of the sector 'Telecom' was transferred to Proximus

when it subscribed to Synductis in January 2015. The share of Eandis in Synductis decreased from 50,00 % to 33,28 %. The investment is now included as an ' investment in Associates ' for an amount of 6 k EUR.

The Group still holds the following participations in business centres:

Since 2007, the Group has subscribed to participations in business centres on the explicit demand of its former shareholder. These business centres are situated in the distribution area of Gaselwest (business centres Kortrijk, Roeselare, Flemish Ardennes and Waregem), Imewo (business centres Bruges, Ghent, Meetjesland and Ostend) and Iveka (business centre Kempen).

## 16. Long term receivables

This category consists almost exclusively of loans to local authorities at market conditions and amounted to 1.155 k EUR at the end of 2015 and 1.426 k EUR at the end of 2014.

## 17. Inventories

(In thousands of EUR)	2015	2014
Raw materials and consumables	46.081	34.692
Write down on inventories	-765	-493
<b>Total</b>	<b>45.316</b>	<b>34.199</b>

The impairment losses amounted to 272 k EUR in 2015 and 121 k EUR in 2014. These amounts were reported in the income statement.

## 18. Trade and other receivables

(In thousands of EUR)	2015	2014
Trade receivables - gross	427.015	399.849
Impairment	-75.763	-77.147
<b>Total trade receivables - net</b>	<b>351.252</b>	<b>322.702</b>
Other receivables	643.882	1.364.945
Other receivables - Transfers	770.826	575.367
<b>Total other receivables</b>	<b>1.414.708</b>	<b>1.940.312</b>
<b>Total trade and other receivables</b>	<b>1.765.960</b>	<b>2.263.014</b>

The information regarding outstanding balances with the associate, was included in the note 'Related parties'.

The detail of the **trade receivables – net** is as follows.

(In thousands of EUR)	2015	2014
<b>Trade receivables from distribution grid activities</b>		
Outstanding debt	235.425	199.096
Impairment	0	0
<b>Trade receivables social customers</b>		
Outstanding debt	101.429	108.270
Impairment	-62.556	-62.626
<b>Other trade receivables</b>		
Outstanding debt	51.743	39.609
Construction works for third parties	29.041	17.878
Impairment	-13.207	-14.521
<b>Trade receivables public authorities, state and country</b>	4.211	18.327
<b>Other</b>	5.166	16.669
<b>Total trade receivable - net</b>	<b>351.252</b>	<b>322.702</b>

The trade receivables from distribution grid activities increase with 36.329 k EUR and amount to 235.425 k EUR at the end of 2015.

The net amount of trade receivables from social customers decreased from 45.644 k EUR in 2014 to 38.873 k EUR in 2015.

The 'Other trade receivables' include an amount of 566 k EUR for 2015 and 1.124 k EUR for 2014 related to bad debts from the period before the energy market's liberalization, as well as receivables related to finished construction works and services rendered and costs still to be billed related to works for third parties.

The trade receivables from distribution grid activities are payable within 18 calendar days following the dispatch of the invoice as provided in the Access Code.

The detail of the **other receivables** is as follows.

(In thousands of EUR)	2015	2014
VAT receivable	88	131
Receivables municipalities	93	316
Green energy and cogeneration certificates	627.085	444.477
Receivables options	3.506	3.541
Others	13.110	916.480
<b>Other receivables</b>	<b>643.882</b>	<b>1.364.945</b>
Transfer tariff	658.965	452.986
Complement to annual energy sales	57.807	63.467
Solidarity receivables related to the certificates for green energy	16.993	31.548
Deferred charges	11.249	4.565
Accrued income	25.812	22.801
<b>Other receivables - Transfers</b>	<b>770.826</b>	<b>575.367</b>
<b>Total other receivables</b>	<b>1.414.708</b>	<b>1.940.312</b>

The decrease in **other receivables** with 721.063 k EUR to 643.882 k EUR was mainly due to the items reported as 'Others' partly compensated by an increase of unsold renewable energy certificates (REC) and combined heat & power certificates (CHPC).

The **RECs and CHPCs** amount to 627.085 k EUR compared to 444.477 k EUR in 2014.

Due to the application of the 'banking principle', being the temporary immobilization of the surplus certificates with a guarantee by the Flemish Region for a certain number of certificates to be sold at an agreed price, and the permanent purchase of certificates this item is increasing further. On the other hand, the certificates are offered for sale at quarterly intervals on the market.

As a result of the steady increase of the amount of RECs, the Flemish Minister of Energy decided to diminish, as from 2016, the unsold certificates (gradually) by increasing the quota of the market and through an increased contribution in an energy fund.

During 2015 and 2014, the certificates were offered for sale on a quarterly basis. A total amount of 22.540 k EUR of RECs were sold in 2015 (2014: 127.176 k EUR) and for 44.022 k EUR CHPCs (2014: 11.034 k EUR). The result from the sale amounts to 87 k EUR profit in 2015 (2014: 10.443 k EUR) and has been included in the item 'Cost of trade goods'.

As from 2014, the value of the RECs and the CHPCs that are not being guaranteed by banking was restated respectively from 93 euro to 88 euro per certificate and from 27 euro to 20 euro per certificate. The result from this operation amounts to 54.504 k EUR and has also been included as a 'Cost of trade goods'. For 2015, the same market price still applies.

The item '**Others**' contains at year-end 2014 an amount paid by Eandis on 29 December 2014 as exit fee to Electrabel, the private partner in the DSOs. This payment was carried out in the name and on behalf of the public authorities (municipalities and cities). The necessary funds were obtained from the issuance of bond loans and bank borrowings (see note 'Interest bearing loans and borrowings'). The settlement with Eandis was carried out early 2015.

**Transfer tariff** is related to the revenue correction that is eligible for inclusion in the following tariff period (see chapter 'Working in a regulated environment – The billing mechanism').

The **complement to the annual energy sales** concerns the estimate of the energy supplied to social customers but not yet invoiced.

#### **Solidarity contribution for RECs**

The cost of green power differs greatly for each distribution area in Flanders. In the Energy Decree, the distribution system operators are committed to a mutual settlement of the costs since 2010. The principles and procedures are initiated by the VREG (Flemish Regulator for Electricity and Gas). Since the settlement can be both a receivable or a liability, this item must be read together with the item reported in the notes 'Trade and other payables'.

The **deferred charges and accrued income** mainly concern the amounts to be settled on the purchase of energy.

## **19. Cash and cash equivalents**

Cash and cash equivalents comprise bank deposits, cash resources and fund investments that are readily exchangeable into cash. At the end of 2015 an amount of 3.656 k EUR was available and 8.913 k EUR at the end of 2014.

All resources are reported in euro.

## **20. Issued capital and reserves**

The various components of equity and the movements from 1 January 2014 to 31 December 2015 were reflected in the 'Statement of changes in equity'.

The **share capital** amounted to 1.278.688.431,18 EUR at the end of 2015 and 2.056.751.688,71 EUR at the end of December 2014. The capital was fully subscribed and paid up. It represents the sum of the capitals of the DSOs.

On 29 December 2014 Electrabel, the private partner in the DSOs exited as a member/partner from the seven DSOs and all of its shares were purchased by the public authorities (municipalities and cities).

To enable this exit, a capital increase was carried out by transferring an amount of 6.076 k EUR from the reserves and 178.242 k EUR from the retained earnings followed by a capital decrease of 51.981 k EUR.

Eandis has carried out the payment to Electrabel in name and on behalf of the public authorities.

In 2015 the funding of this operation was continued as well as the optimization of the DSOs' shareholders' structure. A capital decrease of 885.797.564,22 EUR was carried out on 2 January 2015.

On 9 January 2015 certain municipalities from the DSOs Gaselwest, Imewo, Intergem, Iveka and Iverlek subscribed to a capital increase for a total amount of 61.589.310,01 euro. This capital increase was organized to optimize the capital-cost structure (fair remuneration) of the equity of the associates. The proposed capital increase represented a total amount of 236,3 million euro which was only partially subscribed.

In the second quarter of 2015 the enrollment period of the previous capital increase was re-opened, with the same terms as the initial capital increase. In June 2015, 29.146.555,36 euro was subscribed to.

In April 2015, Sibelgas also subscribed for an amount of 26.998.441,32 euro in the capital.

Finally, Sibelgas reduced its capital on 29 December 2015 for 10.000.000,00 euro to balance the capital ratio with the other DSOs. The amount was recorded as a liability and is disclosed in the note 'Trade and other payables'.

The table below shows a summary of the 2015 movements of the share capital

Date	Transaction	Amount (In thousands of EUR)
<b>31 December 2014</b>		<b>2.056.752</b>
2 January 2015	Capital decrease	-885.798
9 January 2015	Capital increase	61.589
1 April 2015	Capital increase	26.998
29 June 2015	Capital increase	29.147
29 December 2015	Capital decrease	-10.000
<b>31 December 2015</b>		<b>1.278.688</b>

The table below shows the movements in the number of shares and profit certificates per category in the capital of each DSO at the end of 2015.

DSO	Shares A and C		Profit certificates C		Total	
	Number	Capital (In €)	Number	Capital (In€)	Number	Capital (In €)
Gaselwest	23.516.814	272.550.409,97	119	0,00	23.516.933	272.550.409,97
IMEA	13.397.899	126.070.700,07	12	0,00	13.397.911	126.070.700,07
Imewo	21.661.488	257.867.873,74	87	0,00	21.661.575	257.867.873,74
Intergem	11.178.550	97.961.020,49	48	0,00	11.178.598	97.961.020,49
Iveka	18.442.017	199.230.489,93	93	0,00	18.442.110	199.230.489,93
Iverlek	29.444.704	254.083.895,51	103	0,00	29.444.807	254.083.895,51
Sibelgas (1) (2)	3.264.382	70.924.041,47	0	0,00	3.264.382	70.924.041,47
<b>Total</b>	<b>120.905.854</b>	<b>1.278.688.431,18</b>	<b>462</b>	<b>0,00</b>	<b>120.906.316</b>	<b>1.278.688.431,18</b>

(1) Shares C

(2) In Sibelgas, 10.000 shares D are issued without representation in the share capital and 3 shares C

The table below shows the movements in the number of shares and profit certificates per category in the capital of each DSO at the end of 2014.

DSO	Shares A and C		Profit certificates C		Shares/Profit certificates F	
	Number	Capital (In €)	Number	Capital (In €)	Number	Capital (In €)
Gaselwest	13.636.330	215.818.791,76	119	0,00	2.718.294	177.335.132,75
IMEA	6.857.503	78.291.503,34	12	0,00	1.371.491	69.488.003,84
Imewo	13.471.943	241.819.942,33	87	0,00	2.694.379	139.827.154,47
Intergem	7.201.570	97.857.675,40	48	0,00	1.440.300	76.100.180,77
Iveka	10.798.392	157.972.237,48	93	0,00	2.091.014	109.233.217,70
Iverlek	16.177.467	172.569.619,65	103	0,00	3.235.487	153.054.430,90
Sibelgas (1) (2)	4.091.477	12.360.177,25	0	0,00	808.289	22.354.333,22
<b>Total</b>	<b>72.234.682</b>	<b>976.689.947,21</b>	<b>462</b>	<b>0,00</b>	<b>14.359.254</b>	<b>747.392.453,65</b>

DSO	Shares/Profit certificates E''		Shares/Profit certificates E		Total	
	Number	Capital (In €)	Number	Capital (In €)	Number	Capital (In €)
Gaselwest	843.437	54.997.639,49	436.906	15.160.239,04	17.635.086	463.311.803,04
IMEA	571.748	27.094.533,18	1.092.956	29.473.156,59	9.893.710	204.347.196,95
Imewo	74.990	4.616.255,71	1.150.503	37.939.814,00	17.391.902	424.203.166,51
Intergem	135.430	7.114.050,94	178.838	5.240.402,11	8.956.186	186.312.309,22
Iveka	601.258	32.255.094,00	438.610	14.150.572,96	13.929.367	313.611.122,14
Iverlek	1.148.536	55.093.403,62	1.144.387	30.323.036,53	21.705.980	411.040.490,70
Sibelgas	0	0,00	816.927	19.211.089,68	5.716.693	53.925.600,15
<b>Total</b>	<b>3.375.399</b>	<b>181.170.976,94</b>	<b>5.259.127</b>	<b>151.498.310,91</b>	<b>95.228.924</b>	<b>2.056.751.688,71</b>

(1) Shares C

(2) In Sibelgas, 10.000 shares D are issued without representation in the share capital and 3 shares C

The overview of the **reserves** is as follows:

(In thousands of EUR)	Legal reserves	Unavailable reserves	Available reserves	Total
<b>Total at 1 January 2014</b>	<b>1.031</b>	<b>347.722</b>	<b>171.684</b>	<b>520.437</b>
Addition in share capital	0	-6.076	0	-6.076
Transfers to reserves	21	39.155	142.541	181.717
Transfers from reserves	0	0	-16.276	-16.276
Transfer between reserves	0	-380.801	380.801	0
<b>Total at 31 December 2014</b>	<b>1.052</b>	<b>0</b>	<b>678.750</b>	<b>679.802</b>
Transfers to reserves	0	39.288	40.458	79.746
<b>Total at 31 December 2015</b>	<b>1.052</b>	<b>39.288</b>	<b>719.208</b>	<b>759.548</b>



A *legal reserve* has been formed amounting to 1.052.134,94 EUR. This legal reserve has been formed from the profits, at the rate of 5 % until a maximum of 10 % of the fixed part of the share capital as determined by the articles of association.

An *unavailable reserve* has been formed during the period prior to the energy market's liberalization (captive period), according to the guidelines issued by the Flemish authorities for a total amount of 63.832 k EUR.

Since 2008 amounts were included as unavailable reserve equal to the depreciation of the (RAB-added value) revaluation surplus value in accordance with the settlement with the CREG. From 2010 onwards, the costs of the surplus value of land, buildings and installations sold during the accounting year were taken into account. The addition to the reserves for 2015 amounted to 39.288 k EUR and 39.155 k EUR for 2014.

Furthermore, it was decided to transfer during 2014 the total of the unavailable reserves of 380.801 k EUR to the available reserves (see below) and to add a portion to the share capital amounting to 6.076 k EUR.

The total *available reserves* at the end of 2015 amounted to 719.208 k EUR (2014: 678.750 k EUR). The increase in 2015 amounting to 40.458 k EUR stems from the result of the year.

The net movement of 507.066 k EUR of 2014 is due to the inclusion of an amount from the unavailable reserves amounting 380.801 k EUR. Furthermore, the part related to the 'Bonus' 2013 and 2014 amounting to 49.960 k EUR, and 92.581 k EUR from the retained earnings were included, but 16.276 k EUR was withdrawn to guarantee the dividend.

The other components of equity i.e. **other comprehensive income** for 2015 amounted to 651.430 k EUR (2014: 699.505 k EUR) and contain the accumulated actuarial losses relating to pensions and other post-employment employee benefits amounting to 141.464 k EUR and since 2014 also the effect of the recording of deferred taxes for an amount of 509.966 k EUR.

The movement of the actuarial differences for employee benefits amounts to a profit of 51.003 k EUR (2014: 38.824 k EUR loss). This is a result of the changes in the assumptions (see note 'Pensions and other post-employment employee benefit plans').

The movement of the deferred taxes was explained in the note 'Income tax expenses'.

(In thousands of EUR)	2015	2014
Long term employee benefits	-141.464	-192.467
Deferred tax	-509.966	-507.038
<b>Total OCI</b>	<b>-651.430</b>	<b>-699.505</b>

A **non-controlling interest** amounts to 1.079 k EUR, unchanged in comparison to the end of 2014. A non-controlling interest of 35,97 % or 93 k EUR on Farys/TMVW was acknowledged vis-à-vis Farys/TMVW for its participation in De Stroomlijn.

On 17 June 2013, SYNDUCTIS has taken over from AWW its 77 shares in De Stroomlijn for an amount of 7,7 k EUR.

Eandis cvba owns 70,00 % of the shares of the company Indexis cvba, the other shares being held by Ores, the operating company of the Walloon mixed Distribution System Operators for electricity and gas, and by Fernand Grifnée, CEO of Ores (one share). The non-controlling interest therefore amounts to 30,00 % or 986 k EUR.

## Dividend

During the accounting year 2015 dividends were paid for a total value of 185.625 k EUR and 190.202 k EUR in 2014.

In 2014, the dividend payable to the private partner (Electrabel) was included into the exit price for the share transfer of the private partner.

Below is an overview of the dividends paid for 2015 and 2014 as well as per share/profit certificate and per DSO for 2014. As in 2015, only shares A & C and profit certificates C exist, the split is not detailed.

(In thousands of EUR)			Detail 2014 (In EUR)				
DSO	2015	2014	Share A&C	Profit certificate C	Share F	Share/Profit certificate E"	Share/Profit certificate E
Gaselwest	42.155	44.281	2,5824	2,5824	2,5266	2,0432	1,0873
IMEA	16.525	17.414	1,9423	1,9423	1,6932	1,4848	0,8449
Imewo	40.683	40.153	2,4555	2,4555	2,1298	1,9289	1,0333
Intergem	17.926	18.273	2,0553	2,0553	2,1412	1,6460	0,9182
Iveka	26.839	27.513	2,0339	2,0339	1,9589	1,6810	1,0109
Iverlek	36.764	37.529	1,7612	1,7612	1,9660	1,5031	0,8303
Sibelgas	4.733	5.039	0,9006	-	0,9310	-	0,7366
<b>Total</b>	<b>185.625</b>	<b>190.202</b>	<b>2,0843</b>	<b>2,1936</b>	<b>2,0351</b>	<b>1,6818</b>	<b>0,9026</b>

After the balance sheet date the Board of Directors of each of the DSOs has formulated a dividend proposal. The shareholders have approved the payment of these dividend balances at their DSO's General Assembly. According to IFRS these dividends are only reported in the year in which the dividends have been approved. The dividend balance for 2015 amounted to 1.758 k EUR and will be included in the 2016 accounts, the dividend balance for 2014 amounted to 21.512 k EUR and was included in the 2015 accounts.

The amounts mentioned are the net dividends before withholding tax.

The Group's **profit** comprises the fair remuneration, as described in the chapter 'Operating in a regulated environment'.

## 21. Interest bearing loans and borrowings

(In thousands of EUR)	2015	2014
<b>Long term loans</b>	<b>5.197.393</b>	<b>5.533.554</b>
Current portion of long term loans	738.558	516.126
Short term loans	225.238	0
<b>Short term loans</b>	<b>963.795</b>	<b>516.126</b>
<b>Total</b>	<b>6.161.189</b>	<b>6.049.680</b>

At the balance sheet date of 2015, the Group had taken up additional loans amounting to 1111.509 k EUR compared to 2014.  
All loans are expressed in euro.

### Long term loans

Overview of the long-term loans by category  
At the end of 2015

(In thousands of EUR)	2015	Initial amount	Current interest rate %	Maturity
Bond issue - retail	319.970	320.000	4,00 - 4,25	2017-2020
Bond issue - EMTN*	2.639.987	2.660.500	1,75 - 4,50	2021-2033
Bond issue - private**	434.803	440.000	2,60 - 3,55	2027-2044
Bank loans - fixed interest rate	1.761.385	2.350.000	1,24 - 4,76	2016-2035
Bank loans - variable interest rate	34	53.153	0,88 - 2,68	2016
Bank loans - with derivative instrument	779.771	1.270.000	2,97 - 4,56	2023-2027
<b>Total</b>	<b>5.935.951</b>	<b>7.093.653</b>		
Current portion of long term debt	-738.558			
<b>Total long term loans</b>	<b>5.197.393</b>			

At the end of 2014

(In thousands of EUR)	2014	Initial amount	Current interest rate %	Maturity
Bond issue - retail	319.982	320.000	4,00 - 4,25	2017-2020
Bond issue - EMTN*	2.637.816	2.660.500	1,75 - 4,50	2021-2033
Bond issue - private**	434.565	440.000	2,60 - 3,55	2027-2044
Bank loans - fixed interest rate	1.806.489	2.757.916	1,24 - 4,76	2015-2029
Bank loans - variable interest rate	1.792	53.153	0,85 - 2,68	2015-2016
Bank loans - with derivative instrument	849.036	1.270.000	2,97 - 4,56	2023-2027
<b>Total</b>	<b>6.049.680</b>	<b>7.581.569</b>		
Current portion of long term debt	-516.126			
<b>Total long term loans</b>	<b>5.533.554</b>			

\* EMTN: Euro Medium Term Note (is a programme to provide to the Group the flexibility to issue bond loans with different maturities)

\*\* Private: bond issues according to German law: Schuldschein and Namensschuldverschreibung as well as private issues to institutionals (stand alone)

For bank loans – with derivative instrument the Group subscribed to interest rate swaps in order to swap the variable interest rate to a fixed interest rate or some forward interest swaps were concluded (see note ‘Derivative financial instruments’).

For the bond loans issued by Eandis, each of the DSOs is guarantor on a non-joint and non-inclusive basis but limited to its proportional share in the capital of Eandis.

#### Overview of the long term loans issued and borrowings during 2015 and 2014

(In thousands of EUR)	2015	2014	Initial amount	Interest rate %	Maturity
Bank loans - fixed interest rate	400.000	0	400.000	1,52	2035
<b>Total 2015</b>	<b>400.000</b>	<b>0</b>	<b>400.000</b>		
Bond issue – private	50.467	50.413	52.000	3,55	2044
Bond issue – private	22.783	22.773	23.000	3,55	2036
Bond issue – EMTN	541.809	541.196	550.000	2,88	2029
Bond issue – private	169.428	169.409	170.000	3,00	2044
Bond issue - private	94.687	94.671	95.000	2,60	2034
Bond issue - EMTN	397.269	397.019	400.000	1,75	2026
Bank loans - fixed interest rate	188.133	200.000	200.000	1,64	2029
Bank loans - fixed interest rate	90.546	100.000	100.000	1,24	2024
<b>Total 2014</b>	<b>1.555.123</b>	<b>1.575.480</b>	<b>1.590.000</b>		

#### Short term loans

(In thousands of EUR)	Maturity	Available amount	Amounts used	Amounts not used	Average interest rate
Commercial paper	65 m€ on 18/1/2016 & 101,8 m€ on 29/1/2016	522.000	166.800	355.200	0,09%
Fixed advances		200.000	0	200.000	N/A
Fixed loans/Bank overdraft	Daily	200.000	58.438	141.562	0,70%
Fixed loans		100.000	0	100.000	N/A
<b>Total at 31 December 2015</b>		<b>1.022.000</b>	<b>225.238</b>	<b>796.762</b>	

(In thousands of EUR)	Maturity	Available amount	Amounts used	Amounts not used	Average interest rate*
Commercial paper		522.000	0	522.000	N/A
Fixed loans/Bank overdraft	Daily	200.000	0	200.000	N/A
Fixed loans		100.000	0	100.000	N/A
<b>Total 2014</b>		<b>822.000</b>	<b>0</b>	<b>822.000</b>	

\*The average interest rate of the used amounts at the end of the period

All loans, subscribed by Eandis cvba are in the name and on behalf of the DSOs who stand surety for their part and act as joint co-debtor except for the bank overdrafts.

## 22. Pensions and other post-employment employee benefit plans

### Defined contribution plans

Employees hired after 1 January 2002 and the executive staff hired after 1 May 1999 are entitled to defined contribution plans: these pension plans provide in a lump sum on retirement resulting from the contributions paid and the return granted by the pension institutions, as well as a lump sum and orphan interests in case of decease before retirement.

The financing is carried out by employee contributions and employer contributions that are deposited in pension funds (Powerbel and Enerbel) and group insurances.

The assets are managed within a Luxembourg Fund (Esperides), divided in 4 investment zones, each representing different risk profiles (low risk, medium risk, high risk and dynamic asset allocation). The risk level also has to be managed taking into account the age of the members. This is why the trustees of Powerbel have proposed to the members a new option (2014) to manage their assets. This option, called 'Life-Cycle', offers an evolution of the risk exposure from growth to more defensive throughout the member's career.

### Investment risk

According to article 24 of the law of 28 April 2003 on L.P.C. - Loi relative aux Pensions Complémentaires / W.A.P. a minimum average yield for certain pension plans is imposed: currently 3,75 % on employee contributions and 3,25 % on employer contributions.

These guarantees must be reached on resignation or retirement of the members or removal of the pension commitment.

The employee contributions are paid into a group insurance and the employer contributions are paid into a pension fund (Powerbel or Enerbel).

Due to the low level of the interest rates of the bonds it became a challenge for pension institutions to continue to cover the level of the guaranteed interest rates.

A reform was imposed and was announced with the publication on 24 December 2015 of the law of 18 December 2015 to guarantee the sustainability and the social character of supplementary pensions and to strengthen the complementary nature with respect to the retirement pension plans. This law shall enter into force on 1 January 2016.

The guaranteed interest will then be variable and is each year to be aligned on the average return over the last 24 months of linear bonds of the Belgian State (OLOs) with a duration of 10 years (at least 1,75% and maximum 3,75%).

In a group insurance of 'Tak 21' (with yield guarantee) the minimum interest guarantee remains at 3,75 % or 3,25 % up to the date of resignation or retirement on the reserves made up on 31 December 2015. The new interest rate of 1,75 % will be applied to the premiums paid as from 1 January 2016 onwards ("horizontal method").

In a pension fund or a group insurance 'Tak 23' (without yield guarantee) the new interest rate of 1,75 % will be applied on the reserves made up on 31 December 2015 and on the premiums paid as from 1 January 2016 onwards ("vertical method").

As per 31 December 2015 no individual deficits have been noted.

### Defined benefit plans

The Collective Labour Agreement of 2 May 1952 stipulated an additional pension equal to 75 % of the last annual salary after deduction of the legal pension at the end of a complete career, as well as a survival pension and an orphan allowance. This defined benefit plan has been fully paid up by the employer and the pensions have been paid out directly to the beneficiaries. The remaining subsequent obligations are for the largest part related to current pensions.

The majority of the employees hired before 1 January 2002 and the executive staff hired before 1 May 1999 are entitled to defined benefit plans which provide in the payment of a lump sum on retirement, and a lump sum and orphan interest in case of decease before retirement. These benefits are calculated taking into account the last annual salary and past service. The financing is carried out by employee contributions and employer contributions that are deposited in pension funds (O.F.P. Elgabel and O.F.P. Pensiobel) and group insurances.

Due to changes to the pension regulation in Belgium, the members of the pension plan Pensiobel were offered the opportunity to move as from 1 January 2015 to the defined contribution plan Powerbel. The accumulated and improved acquired rights (in Pensiobel) are capitalized at market returns but with a minimum return equal to 3,25 % (cash-balance plan).

The Group also grants **post-retirement allowances** being reimbursement of healthcare costs and tariff benefits.

The **other long term employee benefits** contain provisions for retirement and jubilee bonuses.

### **Actuarial risks**

The defined benefit plans expose the Group to various actuarial risks:

#### *Investment risk*

The present value of the defined benefit plan liability is calculated using a discount rate determined to high quality corporate bond yields. If the return on plan asset is below this rate, it will create a plan deficit. Currently the plan has a relatively balanced investment which is reported in the table below 'Classification of the plan investments on the balance sheet date'.

Due to the long term nature of the plan liabilities, the board of the pension fund considers it appropriate that a reasonable portion of the plan assets should be invested in equity securities to leverage the return generated by the funds.

#### *Interest risk*

A decrease in the bond interest rate will increase the plan liability. However, this will be partially offset by an increase in the return on the plan's debt investments.

#### *Longevity risk*

The present value of the defined benefit plan liability is calculated by reference to the best estimate of the mortality of plan participants both during and after their employment. An increase in the life expectancy of the plan participants will increase the plan's liability.

A study was carried out in 2013 in order to determine the mortality tables that best fit the historical observation of the portfolio. The resulting mortality tables are the MR/FR tables for the pensioners and the MR (corrected with 5 years)/FR (without correction) for the active employees.

From 2015 onwards, new prospective mortality tables are used as proposed by the Institute of Actuaries in Belgium (IA|BE).

#### *Salary risk*

The present value of the defined benefit plan liability is calculated by reference to the future salaries of plan participants. As such, an increase in the salary of the plan participants will increase the plan's liability.

The major actuarial assumptions used at balance sheet date to determine the provision for employee benefits and other allowances:

	2015	2014
Discount rate	1,96%	1,45%
Expected average salary increase (inflation excluded)	0,85%	0,75%
Expected inflation	1,65%	1,75%
Expected increase of health benefits (inflation included)	2,65%	2,75%
Expected increase of tariff advantages	0,25%	0,25%
Average assumed retirement age	62	62
	IA BE Prospective Tables	MR(-5)/FR
Mortality table used		
Life expectancy in years of a pensioner retiring at age 65:		
For a Person aged 65 at closing date:		
- Male	20	23
- Female	24	22
For a Person aged 65 in 20 years:		
- Male	22	23
- Female	26	22

### Amounts recognized in comprehensive income

(In thousands of EUR)	2015	2014
<b>Service cost</b>		
Current service cost	-16.592	-19.609
Cost of early retirement	1.075	-3.204
Past service cost	-5.672	-527
Actuarial (gains)/losses on other long term benefits	3.444	-5.543
<b>Net interest on the net defined benefit liability/(asset)</b>		
Interest cost on defined benefit obligation	-13.124	-26.024
Interest income on plan assets	7.360	14.632
<b>Defined benefit costs recognized in profit or loss</b>	<b>-23.509</b>	<b>-40.275</b>
<b>Actuarial gains/(losses) on defined benefit obligation arising from</b>		
i) changes in demographic assumptions	1.414	0
ii) changes in financial assumptions	40.584	-50.240
iii) changes from experience adjustments	24.599	-20.668
Return on plan assets (excluding interest income)	-15.595	32.085
Change in the effect of the asset ceiling excluding interest on this effect		
<b>Remeasurements of net defined benefit liability/(asset) recognised in Other Comprehensive Income (OCI)</b>	<b>51.003</b>	<b>-38.824</b>
<b>Total</b>	<b>27.494</b>	<b>-79.099</b>

## Amounts recognized in the balance sheet

(In thousands of EUR)	Present value of funded defined benefit obligation	Fair value of plan assets	Funded status
Pensions - funded status	436.719	-508.159	-71.440
Pensions - unfunded status	174.132	0	174.132
Healthcare costs, tariff benefits - unfunded status	168.562	0	168.562
Other long term employee benefits - funded status	63.378	-3.382	59.995
<b>Total defined benefit obligation and long term employee benefits at 31 December 2015</b>	<b>842.791</b>	<b>-511.541</b>	<b>331.250</b>
Pensions - funded status	510.236	-522.398	-12.162
Pensions - unfunded status	187.894	0	187.894
Healthcare costs, tariff benefits - unfunded status	183.908	0	183.908
Other long term employee benefits - funded status	68.995	-3.561	65.434
<b>Total defined benefit obligation and long term employee benefits at 31 December 2014</b>	<b>951.033</b>	<b>-525.959</b>	<b>425.074</b>

## Changes in the present value of the obligation

(In thousands of EUR)	2015	2014
At the beginning of the period	951.033	894.580
Current service cost	15.822	18.160
Interest cost/income	13.124	26.024
Contributions from plan participants	770	1.449
Cost of early retirement	-1.075	3.204
Remeasurement (gains)/losses in Other Comprehensive Income (OCI) arising from		
i) changes in demographic assumptions	-1.250	0
ii) changes in financial assumptions	-43.086	54.596
iii) changes from experience adjustments	-25.932	21.629
Taxes on contributions paid	-2.824	-3.277
Past service cost	5.672	527
Payments from the plan	-69.464	-65.858
<b>At the end of the period</b>	<b>842.791</b>	<b>951.033</b>



## Changes in the fair value of the plan assets

(In thousands of EUR)	2015	2014
Total at 1 January	-525.959	-475.232
Interest income	-7.360	-14.632
Remeasurement gains/(losses) in Other Comprehensive Income (OCI) arising from return on plan assets (excluding amounts included in net interest expense)	15.822	-31.857
Contributions from employer	-60.260	-65.435
Contributions from plan participants	-770	-1.449
Benefit payments	66.987	62.646
<b>Total at 31 December</b>	<b>-511.541</b>	<b>-525.959</b>
<b>Actual return on plan assets</b>	<b>8.462</b>	<b>-46.489</b>

## Classification of the plan investments on the balance sheet date

The classification of the plan investments in function of the major category at the end of 2015

Category	Currency	Elgabel %	Pensiobel %	Insurance companies %	Total %
<b>Investments quoted in an active market</b>		<b>79,66</b>	<b>80,30</b>	<b>76,73</b>	<b>78,88</b>
Shares	Eurozone	19,88	22,37	3,09	15,21
Shares	Outside eurozone	16,59	16,08	3,08	12,40
Government bonds	Eurozone	2,83	2,74	14,57	6,38
Other bonds	Eurozone	28,47	27,59	55,99	36,68
Other bonds	Outside eurozone	11,89	11,52	0,00	8,22
<b>Unquoted investments</b>		<b>20,34</b>	<b>19,70</b>	<b>23,27</b>	<b>21,12</b>
Property		3,92	3,79	4,28	4,37
Qualifying insurance contracts		0,00	0,00	5,47	1,30
Cash and cash equivalents		2,65	2,55	2,03	2,44
Other		13,77	13,35	11,50	13,01
<b>Total in %</b>		<b>100,00</b>	<b>100,00</b>	<b>100,00</b>	<b>100,00</b>
<b>Total (In thousands of EUR)</b>		<b>269.272</b>	<b>86.988</b>	<b>155.281</b>	<b>511.541</b>

The classification of the plan investments in function of the major category at the end of 2014

Category (in %)	Currency	Elgabel	Pensiobel	Insurance companies	Total
<b>Investments quoted in an active market</b>		<b>81,90</b>	<b>82,33</b>	<b>77,26</b>	<b>80,42</b>
Shares	Eurozone	18,17	20,96	2,95	13,57
Shares	Outside eurozone	15,59	15,01	4,40	11,74
Government bonds	Eurozone	2,40	2,31	14,68	6,50
Other bonds	Eurozone	33,95	32,69	55,24	40,86
Other bonds	Outside eurozone	11,79	11,35	0,00	7,76
<b>Unquoted investments</b>		<b>18,10</b>	<b>17,67</b>	<b>22,74</b>	<b>19,58</b>
Property		4,29	4,13	3,71	4,07
Qualifying insurance contracts		0,00	0,00	7,21	2,41
Cash and cash equivalents		0,74	0,95	0,77	0,79
Other		13,07	12,59	11,05	12,31
<b>Total in %</b>		<b>100,00</b>	<b>100,00</b>	<b>100,00</b>	<b>100,00</b>
<b>Total (In thousands of EUR)</b>		<b>256.269</b>	<b>93.561</b>	<b>176.129</b>	<b>525.959</b>

#### Breakdown of the defined benefit obligation by type of plan participants and by type of benefits

(In thousands of EUR)	2015	2014
<b>Breakdown of defined benefit obligation by type of plan participants</b>	<b>842.791</b>	<b>951.033</b>
Active plan participants	557.949	629.608
Terminated plan participants with deferred benefit entitlements	24.498	27.644
Retired plan participants and beneficiaries	260.344	293.781
<b>Breakdown of defined benefit obligation by type of benefits</b>	<b>842.791</b>	<b>951.033</b>
Retirement and death benefits	610.851	698.129
Other post-employment benefits (medical and tariff reductions)	168.562	183.908
Jubilee bonuses (Seniority payments)	63.378	68.996

The results of the **sensitivity analysis** are included below to explain the impact of the assumptions.

(In thousands of EUR)	Effect: increase (+) / decrease (-)
Increase of discount rate (0,5%)	(34.170)
Average salary increase – inflation excluded (0,5 %)	36.170
Increase of inflation (0,25% movement)	31.837
Increase of healthcare care benefits (1,0%)	18.790
Increase of tariff advantages (0,5 % movement)	4.152
Increase of life expectancy of male pensioners (1 year)	4.494
Increase of life expectancy of female pensioners (1 year)	8.990

The annual balance of the defined benefit lump sum is financed by the Group through a recurrent allocation expressed as a percentage of the total payroll. This percentage is defined by the aggregate cost method and is reviewed annually. This method of financing is used to smooth out future costs over the remaining period of the plan. The costs are estimated on projected bases (salary growth and inflation taken into account).

The assumptions related to salary increase, inflation, employee turnover and age-term are defined on the basis of historical statistics of the Group. The mortality tables used are the ones corresponding to the observed experience within the financing vehicle. The discount rate is set up with regard to the investment strategy of the company.

These assumptions are challenged on a regular basis.

Exceptional events (such as modification of the plan, change of assumptions, too short degree of coverage...) can eventually lead to additional payments by the Group.

The average duration of the defined benefit obligation at 31 December 2015 is 8 years (2014: 8 years).

The Group estimates to contribute 31.757 k EUR to the defined benefit pension plans in 2016 and 8.368 k EUR to the defined contribution plans.

## 23. Derivative financial instruments

The Group has entered into interest rate swaps in order to convert the variable interest rate on long term loans into a fixed interest rate. The derivative financial instruments have been measured at fair value for 145.715 k EUR in 2015 and 169.839 k EUR in 2014.

The changes in the fair value are recognized in the income statement (see note 'Financial results').

The fair value of derivative financial instruments entered into for hedging the interest rate risk is calculated on the basis of the discounted expected future cash flows taking into account current market interest rates and the yield curve for the instrument's remaining maturity.

### *Overview of the derivative financial instruments*

A Linear constant maturity swap within the framework of the original 200 million EUR loan with a maturity of 20 years concluded in June 2003 entered into force in June 2013.

A Linear constant maturity swap within the framework of the original 220 million EUR loan with a maturity of 20 years concluded in December 2004 entered into force in December 2014.

A Linear constant maturity swap within the framework of the original 200 million EUR loan with a maturity of 20 year concluded in December 2004 entered into force in December 2009.

A Bonus Range Accrual within the framework of the original 250 million EUR loan with a maturity of 20 year loan concluded in December 2006 entered into force in December 2011.

A Varifix within the framework of the original 250 million EUR loan with a maturity of 20 year concluded in December 2007 entered into force in October 2010.

A forward fixing IRS swap was concluded in July 2013 within the framework of a loan subscribed to in December 2013 for an amount of EUR 150 million over 10 years.

## 24. Provisions

(In thousands of EUR)	Rehabilitation	Other	Total
Total at 1 January 2014	24.138	596	24.734
Used	-4.258	0	-4258
<b>Total 31 December 2014</b>	<b>19.880</b>	<b>596</b>	<b>20.476</b>
Used	-2.192	-257	-2.449
<b>Total at 31 December 2015</b>	<b>17.688</b>	<b>339</b>	<b>18.027</b>

The provisions comprise the obligations recognized for the rehabilitation of the former gas factories' grounds. The DSOs own several gas factory grounds on which soil and groundwater have been polluted in the past. Tackling this pollution has already started on a voluntary basis and a framework agreement with OVAM was concluded in 2001. Meanwhile, the number of such grounds has been reduced. In a new agreement with OVAM, it will be determined what the spread in time, the budget, the order of priority and the modalities of execution of the works for rehabilitating the soil, and possibly other measures, will be.

A bank guarantee was given to OVAM for an amount of 10.764 k EUR in 2015 and 12.725 k EUR in 2014 within the framework of the transfer of a number of grounds, conforming to the applicable legislation.

The Group is working on possible sales of certain contaminated sites. In this context, several grounds were sold during 2012 and letters of intent were entered into with potential buyers.

On certain grounds already sold, rehabilitation duties still remain for an amount of 910 k EUR in 2015 and 710 k EUR in 2014 (see note 'Contingencies').

The decrease to the provision for rehabilitation was due to the use of (remediation) and more concrete elements for the estimation of the clean-up costs. No amounts were reversed nor were any amounts added to the provisions during 2015 and 2014.

The provision 'Other' relates to expenses for litigations with third parties and other provisions based upon the management's best possible estimate of the expenses that the Group might incur.

The expected timing of cash outflow is dependent upon the duration and the settlement of the various procedures.

## 25. Government grants

(In thousands of EUR)	2015	2014
Total at 1 January	0	214
Received during the year	0	-15
Released to the income statement	0	-226
<b>Total at 31 December</b>	<b>0</b>	<b>0</b>

In the framework of the participation in the EVA project investment grants were granted mainly by the 'Agentschap voor Innovatie door Wetenschap en Technologie' (IWT). As the project ran until the end of September 2014, the settlement was made based on the investments carried out at that time.

## 26. Trade payables and other liabilities

(In thousands of EUR)	2015	2014
Trade debts	268.099	161.155
VAT and other taxes payable	2.958	12.298
Remuneration and social security	62.756	65.763
Advances Soclev clients and other	34.211	36.589
Solidarity payables related to the certificates for green energy	71.935	55.971
Other current liabilities	207.512	237.688
<b>Total</b>	<b>647.471</b>	<b>569.464</b>

The items related to trade payables and other liabilities increase by 78.007 k EUR in comparison to 2014. The increase is the result of on the one hand, the increase in trade payables of 106.944 k EUR and solidarity payable for green energy certificates of 15.964 k EUR, and on the other hand, the decrease of other current liabilities with 30.176 k EUR.

The increase in trade payables mainly relates to the recording of accrued debts for the contribution of 100 kWh free of charge (46.645 k EUR) and the fact that for one of the major suppliers the invoices were not immediately paid anymore.

Since the settlement of the solidarity related to the certificates for green energy can be both a receivable or a liability, this item must be read together with the item reported in the notes 'Trade and other receivables'.

The major items related to the 'Other current liabilities' comprise a debt to shareholders amounting to 10.015 k EUR (2014: 51.981 k EUR) and the reserved amounts concerning the Bonus 2014 and 2013 amounting to 64.267 k EUR (2014: 64.267 k EUR) as reported under the

heading 'Share capital and reserves'. This section also contains charges to be allocated related to among others the interest expenses and costs on bond loans for an amount of 43.854 k EUR (2014: 45.968 k EUR).

Furthermore, it was decided to transfer in 2015 the accumulated funds from allotments built up until 2014 (23.368 k EUR) and the long term debt amounting to 2.285 k EUR as a debt for profit distribution amounting to 25.652 k EUR. The funds from allotments of 2015 are still recorded as deferred income and amount to 7.161 k EUR (2014: 23.368 k EUR).

The term and the conditions for the debts are as follows:

For the standard trade debts the average payment term amounted to 50 days after invoice date and for contractors 30 days after invoice date.

Debts for VAT and withholding tax are paid respectively 20 and 15 days after the end of the month. All debts are paid by the maturity date.

## 27. Current tax liabilities

(In thousands of EUR)	2015	2014
Tax expenses on current year result	122.605	5.796
Tax increase	739	0
Advances paid	-16.020	-2.557
Deductable withholding tax	-114	-423
<b>Tax expense current year</b>	<b>107.210</b>	<b>2.816</b>
<b>Tax expenses on previous years</b>	<b>268</b>	<b>304</b>
<b>Total tax expenses</b>	<b>107.478</b>	<b>3.120</b>

## 28. Financial instruments: policy

### Risks

It is the Group's intention to understand all risks separately, as well as their mutual connections, and to define strategies in order to manage the economic impact on the Group's results. The Audit Committee is responsible for reviewing the risk analysis, for the approval of the recommended risk management strategies, and for compliance with the guidelines on risk management and reporting.

### Equity structure

The Group's equity structure consists of equity and the financial liabilities.

Apart from the legally (Belgian) required minimum levels for equity that are applicable, the mission charged associations are also subject to the Flemish Decree on Intermunicipal Cooperation. This decree stipulates that by the end of 2018 at the latest no Private Partner / shareholder can participate in the share capital of mission charged associations (the principle of mixed mission charged associations companies will disappear). For the ex IGAO municipalities

(in IMEA, Intergem and Iveka), Iveka and Intergem this date is earlier, being 31 December 2014, 31 December 2016 and 14 September 2018 respectively.

On 29 December 2014 the share of the private partner/participant Electrabel N.V. in equity (Belgian GAAP) was purchased by the public participants.

The purpose of the Group is to maintain a strong balance sheet structure and to ensure that the Group can retain a 'good' credit rating from the credit rating offices. Hence, the Group is preparing the participation of a private partner and its statutory structure will be adjusted therefore (see note 'Events after the balance sheet date'). Also, some financing intermunicipal companies may be interested to participate in the share capital.

As the Group works within a regulated environment with a guaranteed remuneration (fair remuneration/profit and a guaranteed return/dividend), the risk is rather limited. During 2015 and 2014 the Group fulfilled all 'expected' obligations.

The Group has called upon long and short term funding to support its capital structure. The Group monitors its solvency. Solvency means the degree to which the Group, in case of liquidation, can meet its financial obligations towards the providers of debt capital.

#### Credit risk

The credit risk comprises the risk that one party to a financial instrument will cause a financial loss for the other party by failing to discharge an obligation.

The Group pursues a credit policy whereby the credit risk is scrutinized and diversification of counterparties is necessary.

The maximum credit risk is each financial asset's balance sheet value.

#### Trade debtors

Ageing analysis of trade receivables past due, but not impaired

(In thousands of EUR)	2015	2014
1 - 60 days	12.285	-891
61 - 90 days	2.877	3.391
91 - 180 days	7.368	10.411
181 - 365 days	15.203	17.479
>365 days	20.101	18.679
<b>Total trade receivable - net</b>	<b>57.834</b>	<b>49.069</b>

## Movements in accumulated impairments on trade receivables

(In thousands of EUR)	2015	2014
<b>Balance at 1 January</b>	<b>-77.145</b>	<b>-90.815</b>
Charge of impaired receivables	-5.541	-6.688
Write back of impaired receivables	6.925	20.358
<b>Total at 31 December</b>	<b>-75.761</b>	<b>-77.145</b>

### Currency risk

The Group is not substantially exposed to currency risk since transactions in currencies other than the euro are limited.

### Liquidity risk

The liquidity risk implies the risk that the Group will encounter difficulties in meeting its obligations associated with financial liabilities. The Group limits this risk by scrutinizing cash flows continually and by taking care that a sufficient number of credit facilities are available.

The Group can call upon several banks to attract resources on **short term**. It has the possibility to issue commercial paper within the framework of a treasury bill programme, to draw upon fixed advances with a maturity of one week up to twelve months and to take up straight loans with a maturity between one day up to one year. All loans have fixed interest rates except for the bank overdraft that has a variable interest rate.

The Group borrows on a **long term** basis mainly to finance its ongoing investments in the distribution grid and to refinance loans and pay interest. During 2014 the collected cash of these debentures was used to also pay the exit fee to Electrabel.

During 2010, the Group issued for the first time bond loans aimed at private investors in Belgium and the Grand Duchy of Luxembourg.

To diversify and broaden its funding resources, so that a safe, reliable, efficient, and innovative distribution of energy to the customers can be assured, Eandis has requested a rating from Moody's Investors Service ('Moody's').

In October 2011, Moody's granted Eandis an '**A1**' **credit rating** 'with a negative outlook.' This rating was confirmed by Moody's on 10 September 2015.

Eandis successfully issued bonds in the framework of its € 5 billion Euro Medium Term Note (EMTN) programme. There has always been a large interest from European investors for the bond issuances and also interest from private investors to whom several bond loans were issued.

In the framework of the € 5 billion EMTN programme an amount of € 2.660 million or 53,21 % was issued at the end of 2014. During 2015 no issues have taken place.

An overview of the loans is included in the note 'Interest bearing loans and borrowings'.



The following schedule shows the maturity schedule of the different loans.  
At the end of 2015

(In thousands of EUR)	2015	1 year or less	2-3 year	4-5 year	More than 5 year
Bond issue - retail	319.970	0	150.038	169.932	0
Bond issue - EMTN	2.639.987	0	0	0	2.639.987
Bond issue - private	434.803	0	0	0	434.803
Bank loans - fixed interest rate	1.761.385	667.004	215.675	197.763	680.944
Bank loans - variable interest rate	34	34	0	0	0
Bank loans - with derivative instrument	779.771	71.519	150.087	159.796	398.369
<b>Total</b>	<b>5.935.951</b>	<b>738.558</b>	<b>515.799</b>	<b>527.491</b>	<b>4.154.103</b>
<b>Total bullet payment</b>	<b>3.894.760</b>	<b>500.000</b>	<b>150.038</b>	<b>169.932</b>	<b>3.074.790</b>
<b>Total bullet payment excluded</b>	<b>2.041.191</b>	<b>238.558</b>	<b>365.762</b>	<b>357.559</b>	<b>1.079.313</b>

At the end of 2014

(In thousands of EUR)	2014	1 year or less	2-3 year	4-5 year	More than 5 year
Bond issue - retail	319.982	0	150.064	0	169.918
Bond issue - EMTN	2.637.816	0	0	0	2.637.816
Bond issue - private	434.565	0	0	0	434.565
Bank loans - fixed interest rate	1.806.489	445.104	738.494	186.231	436.660
Bank loans - variable interest rate	1.792	1.757	34	0	0
Bank loans - with derivative instrument	849.036	69.264	145.374	154.895	479.502
<b>Total</b>	<b>6.049.680</b>	<b>516.126</b>	<b>1.033.966</b>	<b>341.126</b>	<b>4.158.461</b>
<b>Total bullet payment</b>	<b>4.192.363</b>	<b>300.000</b>	<b>650.064</b>	<b>0</b>	<b>3.242.299</b>
<b>Total excluding bullet payment</b>	<b>1.857.317</b>	<b>216.126</b>	<b>383.902</b>	<b>341.126</b>	<b>916.162</b>

### Interest rate risk

The Group has entered into long-term loans with a fixed and variable interest rate. Loans with variable interest were swapped to a fixed interest rate (see note 'Derivative financial instruments'). For certain loans, forward swap contract were concluded. All other loans were initially at a fixed interest rate.

The interest payment for the following years, calculated on the basis of the current interest rate, is as follows:

(In thousands of EUR)	2015	2014
In 2015	0	199.234
In 2016	192.817	186.704
In 2017	156.404	150.587
In 2018	158.865	153.299
In 2019	145.301	140.007
In 2020	138.777	133.757
In 2021 and later	763.306	724.039
<b>Total</b>	<b>1.555.471</b>	<b>1.687.626</b>

#### Other

More information about the risks of the Group and its shareholders is included in the prospectus of the Eandis group (Eandis cvba and its subsidiaries) dated 25 November 2014 concerning the guaranteed Euro Medium Term Note Programme. This document can be consulted on the website [www.eandis.be](http://www.eandis.be).

#### Fair value

The fair value is the amount for which an asset could be exchanged or a liability settled between knowledgeable, willing parties that are independent in an arm's length transaction and not in a forced sale or liquidation sale.

(In thousands of EUR)	Level 1	Level 2
Other investments	1.134	0
Green energy and cogeneration certificates (GEC & CGC)	627.085	0
Trade and other receivables excluded GEC and CGC	1.138.875	0
Cash and cash equivalents	3.656	0
<b>Total</b>	<b>1.770.750</b>	<b>0</b>
Loans on short term	225.238	
Bond loans	3.741.669	0
Loans on long term (included short term part)	2.541.190	0
Derivative financial instruments	0	145.715
<b>Total</b>	<b>6.508.097</b>	<b>145.715</b>

#### Fair value hierarchy

The Group uses the following fair value hierarchy classification to determine and classify the fair value of the financial instruments by a valuation technique:

Level 1: valuation is based on quoted (unadjusted) prices in an active market for identical assets or liabilities

Level 2: other techniques for which all input with a significant impact on the recorded fair value can be observed either directly or indirectly

Level 3: techniques that use input with a significant impact on the recorded fair value that is not based on observable market data.

The following methods and assumptions were used to estimate the fair values:

Cash and short term deposits, trade receivables (net of impairment), trade payables and other current liabilities approximate the carrying amounts as to the short term maturity of these instruments.

The fair value of the unquoted other investments is based on the latest available financial information.

The fair value of the certificates for green energy and cogeneration certificates are the guaranteed amount, as stipulated in the decision of the Flemish Government amending the Energy Decree. The fair value of the quoted bond loans is based on the price quotations at the reporting date.

The derivative financial instruments are interest rate swaps. The valuation techniques are swap models that use value calculations. The models include various kinds of input including forward prices, yield curves that are obtained on the basis of market interest rates and derivatives from market prices of various financial products that are requested with various market participants.

The fair value was obtained on the basis of the indicative quotations on Bloomberg (Bloomberg is a prominent provider of business and financial market news. On the reporting date it delivers world economic news, quotes for stock futures, stocks and other).

The fair value of the quoted bonds, issued for a total amount of 2.980,5 million EUR varies according to the market interest rate. The fair value at 31 December 2015 amounts to 3.301,7 million EUR and differs from the amount that will be reimbursed and the carrying value.

## 29. Related parties

Transactions between the DSOs and their subsidiaries (the associated parties) have been eliminated in the consolidation process and are therefore not included in this note.

The remunerations paid to the directors are attendance fees and transport fees for an amount of 635.792,42 EUR in 2015 and 747.675,69 EUR for 2014.

The remunerations paid to the management committee and the directors amounted to 3.562.056,96 EUR for 2015 and 3.270.717,61 EUR for 2014. The post-employment benefits included in the total remuneration mentioned amounted for 2015 to 786.435,55 EUR and for 2014 to 687.828,86 EUR. There are no other benefits in kind, share options, credits or advances granted to the directors.

Transactions of the Group and non-controlling interest companies (Farys/TMVW, AWW (up to 2014) and Ores Assets/Ores) were as follows:

(In thousands of EUR)	2015	2014
<b>Amount of the transactions</b>		
Recharge of costs to non-controlling interest companies	11.484	12.049
Recharge of costs from non-controlling interest companies	3.045	2.938
<b>Amount of outstanding balances</b>		
Trade receivables	1.513	2.137
Trade payables	251	711
Provide financing	0	1.020

Transactions of the Group and associated companies (Atrias and Synductis) were as follows:

(In thousands of EUR)	2015	2014
<b>Amount of the transactions</b>		
Recharge of costs to associates	2323	637
Recharge of costs from associates	5.823	2.796
<b>Amount of outstanding balances</b>		
Trade receivables	11.270	5.691
Trade payables	1251	448

*Membership of professional organisations*

Eandis is a member of Synergrid vzw, which is the Belgian common interest federation of the electricity and gas transport and distribution grid operators.

Eandis is a member of the European Distribution System Operators for Smart Grids (EDSO for Smart Grids).

During 2015 the parent companies DSOs paid fees of 57 k EUR to the statutory auditor and an amount of 74 k EUR for other assignments.

### 30. Contingencies

(In thousands of EUR)	2015	2014
Rent deposits, buildings	1.374	1.374
Other bank guarantees	11.114	13.074
<b>Guarantees given</b>	<b>12.488</b>	<b>14.448</b>
Guarantees obtained from contractors and suppliers	43.848	33.813
Goods held by third parties in their own name but at risk for the Group	45	99
Obligation to purchase property, plant and equipment	3.570	2.767
Obligation to sell property, plant and equipment	500	0
Obligation to rehabilitation	910	710

Outstanding orders in 2015 amounted to 20.786 k EUR (2014: 35.044 k EUR).

The Group has rented several buildings and adjoining parking lots for a total value of 6.055k EUR in 2015 and 5.710 k EUR in 2014, as well as cars for a total value of 4.883 k EUR in 2015 and 6.088 k EUR in 2014.

The future rent obligations (operational rent obligations) concern buildings, vehicles and other materials.

The contracts relating to buildings contain renewal clauses and have an average term of two years.

The future minimum lease payments under non-cancellable finance leases are as follows.

(In thousands of EUR)	2015
In 2016	9.977
In 2017 en 2018	10.120
In 2019 en 2020	2.979
<b>Total</b>	<b>23.076</b>

The Group's budgeted investments for 2015 were estimated at 532.096 k EUR (658.788 k EUR in 2014).

Furthermore, there is also a legal dispute ongoing between the DSOs and Essent concerning free distribution of green electricity (3.533 k EUR for 2015 and 2014), with the NMBS and the Flemish Region on grid displacements (5.594 k EUR in 2015 and 5.819 k EUR in 2014) and disputes with various parties (for a total of 11.693 k EUR in 2015 and 14.548 k EUR in 2014).

The Group is involved in legal disputes for which the risk of loss is possible but not likely and for which, as a result, no provisions have been set up. Currently, the possible timing of the settlements cannot be estimated reliably.

### **31. Events after the reporting date**

The following statutory transactions have taken place at 1 January 2016:

Concerning the Distribution System Operators:

To meet the future challenges (such as the introduction of smart technologies, conversion of the gas network to high calorific gas) and to meet the refinancing needs, the balance sheet structure needs strengthening.

If the possibility of attracting new private capital is offered, it is preferred that the participation will take place in one entity rather than in seven separate entities.

Therefore, the decision was taken by the General Assembly to merge, as from 1 January 2016 the seven Eandis-distribution system operators (Gaselwest, Imea, Imewo, Intergem, Iveka, Iverlek and Sibelgas) into one Distribution System Operator, with the name Eandis Assets, but with conditions precedent.

Eandis Assets will take as legal form a 'mission charged association with private participation' under application of the (to be amended) Decree of 6 July 2001.

As a result, starting from 2016 a legal consolidation of the Eandis Assets Group should be performed according to Belgian legislation and IFRS. The impact will further be investigated by the company.

Prior to this merger by absorption (Gaselwest takes over the six other Eandis-DSOs) the statutory aim was adapted as well as a partial split of Gaselwest was carried out, separating the municipalities served by Gaselwest in Wallonia into a newly established Flemish Mission Charged Association. This new DSO with the name Gaselwest-Zuid was constituted comprising the following four Walloon municipalities, Comines-Warneton, Ellezelles, Mont-de-l'Enclus and Celles that were co-shareholders of the distribution system operator Gaselwest, The new DSO will, for the time being, call on Eandis System Operator as operating company.

A fifth Walloon municipality however, Frasnes-lez-Anvaing, switched to Ores, but Eandis System Operator remains active as operating company as a subcontractor of Ores.

Concerning the operating company Eandis, subsidiary of the DSOs:

On 1 January 2016, the activities and the staff of Indexis cvba were incorporated by Eandis cvba. The non-controlling interest in Indexis, held by Ores, was then transferred to the DSOs of Eandis. Within Eandis, this merger acquisition also leads to a capital increase of the current capital of 18.550 euro to 915.124,89 euro.

The name of Eandis cvba was changed to Eandis System Operator cvba (ESO).

On 7 January 2016 Moody's has confirmed that these registered transactions do not affect the current A1 rating, with negative outlook of Eandis.

## 32. List of group entities included in the consolidation

Subsidiary	Registered office	Number of shares owned (%)	Voting rights (%)
<b>Distribution System Operators *</b>			
Gaselwest	President Kennedypark 12, B-8500 Kortrijk		
IMEA	Merksemsesteenweg 233, B-2100 Deurne		
Imewo	Brusselsesteenweg 199, B-9090 Melle		
Intergem	Administratief Centrum (AC), Franz Courtensstraat 11, B-9200 Dendermonde		
Iveka	Koningin Elisabethlei 38, B-2300 Turnhout		
Iverlek	Aarschotsesteenweg 58, B-3012 Wilsele-Leuven Gemeentehuis St. Joost-Ten-Node, Sterrenkundelaan 12, B-1210		
Sibelgas	Brussels		
<b>Subsidiaries</b>			
Eandis cvba	Brusselsesteenweg 199, B-9090 Melle	100,00	100,00
De Stroomlijn cvba	Brusselsesteenweg 199, B-9090 Melle	64,03	64,03
Indexis cvba	Ravensteingalerij 4 bus 2, B-1000 Brussels	70,00	70,00
Atrias cvba	Ravensteingalerij 4 bus 2, B-1000 Brussels	25,00	25,00
Synductis cvba	Brusselsesteenweg 199, B-9090 Melle	33,28	32,81

\* Address of contact: Brusselsesteenweg 199, B-9090 Melle

The subsidiary SYNDUCTIS cvba founded on 21 December 2012 was - until the end of 2014 - included as an 'other investment' in the consolidation. Eandis held 50 % of the shares. Since Proximus joined in early 2015, the Group still holds 33,28 % of the shares and since then reports this company as an associate.

The company Eandis cvba together with its subsidiaries De Stroomlijn cvba, Indexis cvba, Atrias cvba and SYNDUCTIS cvba form the (legal) 'Eandis group'. This group reports its IFRS results, which can be consulted on the website [www.Eandis.be](http://www.Eandis.be).

## Operating in a regulated environment

### **Renewal of permission to call on the operating company**

The Flemish energy regulator VREG has by its decision of 24 February 2015 granted the permission to the DSOs to call on the services of Eandis cvba as operating company for electricity. This authorisation applies as from 5 September 2014 and is valid for a period of twelve years.

### **Recognition of the distribution system operators**

The Flemish energy regulator VREG reported, by letter of 6 February 2015, its decision of 3 February 2015 to renew the recognition of the 7 DSOs as electricity distribution system operators. This designation is valid for a period of 12 years starting from 5 September 2014. On 29 September 2015 the VREG decided to renew the term for the 7 DSOs for gas distribution for a period of 12 years beginning on 14 October 2015. At the same time, the permission to operate with Eandis cvba as operating company for gas was authorized.

### **Regulated tariff methodology**

The Group operates in a regulated environment and hence revenue is based on tariff rates that were approved by the regulator.

As a result of the Sixth State Reform the VREG – Flemish Regulator of the electricity and gas markets - has as from 1 July 2014, retrieved the competence of the federal regulator CREG to determine the tariff methodology for the Flemish region.

Consequent to the transfer of authority, it was decided to prolong the tariffs that were in effect in the year 2012 into the following years 2013 and 2014.

On 30 September 2014 the VREG determined a new tariff rate methodology for electricity and gas for the DSOs active in the Flemish region for the regulatory period 2015-2016. They considered that the hybrid model used in the past for establishing the tariff methodology no longer could be continued under the same form as there were too many limitations and drawbacks.

In building the new tariff method the following elements were taken into account: promoting efficient operations, information asymmetry, stability, transparency, administrative efficiency and avoiding rate volatility. This method should be an incentive for the DSOs to work in a cost-efficient and sustainable manner.

The costs are divided into three categories that also have another determination of its related income: The exogenous costs are the costs for which the DSO has no control because they are imposed: the cost of GEC, cogeneration certificates, premiums for RUE and social public service obligations.

The non-exogenous costs include the cost of depreciation, the operational costs and the compensation for the cost of capital. Other costs include the fines.

The allowable income will be determined as follows:

The income related to the exogenous costs is tailored to the exogenous costs.

The income for the non-exogenous costs follows a stimulating revenue regulation to support efficient operations.

The remaining costs are borne by the distribution system operator.



The capital remuneration is referred to by the VREG as the total of the average regulated assets at a stipulated cost of capital (4,8 %) and the accepted net operating capital at a determined level (4,1% and legal interest).

The recording of the exogenous costs at their actual value will give rise to differences between the rates and accounting costs. These balances should be booked on specific accounts and are named 'regulatory balance' in contrast to the differences from previous tariff methodologies that are named 'regulatory assets/liabilities'.

There are two regulatory balances allowed: a regulatory balance for exogenous costs and a regulatory balance for the volume differences regarding the revenue for non-exogenous costs.

### **Regulatory assets/liabilities of the past**

The CREG has fixed the amounts of the regulatory assets/liabilities from the financial years 2008 and 2009. These may be recuperated in accordance with the amounts that were agreed upon by the VREG, being half of the amount in 2015 and the other half in 2016.

On 30 June 2015, the Brussels Court of Appeal ruled that the VREG is competent to determine the regulatory balances of the period 2010 to 2014 as well as their destination.

In its decision of 5 October 2015 the VREG ruled that for the time being 20% of the deficits of this period can be recharged in the tariffs of 2016.

### **Budget 2015-2016**

The eligible income for the period 2015-2016 is made up of a portion related to the allowed income for exogenous costs and a portion for non-exogenous costs. There is a budget proposal submitted by the DSOs based on a reporting model.

The income related to the non-exogenous cost is determined on the basis of the evolution of the non-exogenous sector costs for a historical period of four years (2010-2013) which, according to a linear regression technique will determine the future income. Inflation is taken into account by discounting the costs to their current value. Also an annual adjustment for inflation is taken into account, based on the consumer price index (CPI) of August.

The data and information provided by the DSO in the reporting model regarding prior financial years, need to be controlled by the Auditor who needs to submit a report of factual findings (assurance report) to the VREG.

### **Changes to the 2015 tariffs**

On 18 December 2014, the VREG approved the tariffs for the DSOs for 2015.

Eandis has asked for an adjustment on the proposed tariffs, because the federal contribution (decrease) and the Elia-tariff (increase) were changed after the submission. The VREG changed the tariffs accordingly as from 1 March 2015.

There was also a request for an adjustment to the tariffs following the transition from the **legal entity tax** to the corporate income tax of the DSOs. The adjustment of the rates will start from **1 August 2015** onwards. The amount not yet recovered of corporate income tax for the tax year 2015 will be settled in 2016 on top of the corporation tax for the tax year 2016.

A further change concerns the increase of the VAT rate for electricity as from 1 September 2015.

### **Approved tariffs for 2016**

On 14 December 2015 the VREG published the distribution tariffs for electricity and gas.

The main changes concern the **provisional recharge of 20%** of the accumulated deficit (regulatory active) from the period 2010-2014, the abolishment of the **100 kWh free electricity** and the full globalization in Flanders of the cost of green energy by also removing the ceiling that was used the past for the settlement.

### Accounting treatment

At the moment there are no specific IFRS guidelines as to the accounting treatment of the settlement mechanism in a regulated environment.

On 30 January 2014 the IASB published a new standard "IFRS 14 Regulatory Deferral Accounts". This new standard is applicable for "first time adopters" and allows the recording of regulated assets and liabilities as separate items of the balance sheet and profit and loss account.

**Overview** of the assets and liabilities of the settlement mechanism (see note 'Trade and other receivables' and 'Trade and other short-term liabilities').

(In thousands of EUR)	2015	2014
<b>Regulatory assets - Transfers</b>		
<u>Recoverable in 2015-2016</u>	53.726	0
Transfer 2008	19.770	0
Transfer 2009	33.956	0
<u>Recoverable in later years</u>	345.534	452.986
Transfer 2008	282	39.822
Transfer 2009	-120	67.792
Transfer 2010	-12.686	-12.686
Transfer 2011	87.347	87.347
Transfer 2012	182.702	182.702
Transfer 2013	-13.986	-13.986
Transfer 2014	101.995	101.995
<b>Total transfers</b>	<b>399.260</b>	<b>452.986</b>
<b>Regulatory assets - Balances</b>		
<b>Total balances from 2015</b>	<b>259.705</b>	<b>0</b>
<b>Total net amount recoverable</b>	<b>658.965</b>	<b>452.986</b>
of which reported as Current assets	658.965	452.986

Reconciliation of the settlement mechanism.

(In thousands of EUR)	2015	2014
<b>Regulatory assets at 1 January</b>	<b>452.986</b>	<b>350.991</b>
Additional transfers from 2014	0	101.995
Additional balances from 2015	259.705	0
<b>Total additional balances and transfers</b>	<b>259.705</b>	<b>101.995</b>
Recovered transfers from 2008	-19.770	0
Recovered transfers from 2009	-33.956	0
<b>Total recovered transfers</b>	<b>-53.726</b>	<b>0</b>
<b>Total movements</b>	<b>205.979</b>	<b>101.995</b>
of which - movement through the income statement	205.979	101.995
<b>Regulatory assets at 31 December</b>	<b>658.965</b>	<b>452.986</b>

Free translation from the Dutch original

## **Statutory auditor's report to the shareholders of the Flemish distribution net owners on the consolidated financial statements of the Economical Group Eandis as of and for the year ended 31 December 2015**

We report to you on the performance of our mandate which was assigned to us by the Board of Directors of Eandis CVBA. This report includes our opinion on the consolidated balance sheet as at 31 December 2015, the consolidated statement of the realized and non-realized results, the consolidated statement of changes in equity and the consolidated statement of cash flows for the year for the year ended 31 December 2015 and the notes (all elements together "the Consolidated Financial Statements") and includes as well our report on other legal and regulatory requirements. The consolidated financial statements of the Economical Group Eandis consists of seven Flemish Distribution System Operators (DSOs): Gaselwest, IMEA, Imewo, Intergem, Iveka, Iverlek and Sibelgas who have joint control over Eandis CVBA and its subsidiaries (De Stroomlijn CVBA, Indexis CVBA, Synductis CVBA and Atrias CVBA).

### **Report on the Consolidated Financial Statements - Unqualified opinion**

We have audited the Consolidated Financial Statements of the Economical Group Eandis (together "the Group") as of and for the year ended 31 December 2015, prepared in accordance with the *International Financial Reporting Standards* as adopted by the European Union, which show a consolidated balance sheet total of € 9.723.188 thousand and of which the consolidated income statement shows a profit for the year of € 284.443 thousand.

### *Responsibility of the Board of Directors of Eandis CVBA for the preparation of the Consolidated Financial Statements*

The Board of Directors of Eandis CVBA is responsible for the preparation of Consolidated Financial Statements that give a true and fair view in accordance with the *International Financial Reporting Standards* as adopted by the European Union. This responsibility includes: designing, implementing and maintaining internal control relevant to the preparation of Consolidated Financial Statements that give a true and fair view and that are free from material misstatement, whether due to fraud or error; selecting and applying appropriate accounting policies; and making accounting estimates that are reasonable in the given circumstances.

### *Responsibility of the statutory auditor*

Our responsibility is to express an opinion on these Consolidated Financial Statements based on our audit. We conducted our audit in accordance with International Standards on Auditing ("ISAs"). Those standards require that we comply with the ethical requirements and plan and perform the audit to obtain reasonable assurance about whether the Consolidated Financial Statements are free from material misstatement.

**Audit report dated 23 March 2016 on the Consolidated Financial Statements  
of the Economical Group Eandis as of and  
for the year ended 31 December 2015 (continued)**

An audit involves performing procedures to obtain audit evidence about the amounts and disclosures in the Consolidated Financial Statements. The procedures selected depend on the statutory auditor's judgment, including the assessment of the risks of material misstatement of the Consolidated Financial Statements, whether due to fraud or error. In making those risk assessments, the statutory auditor considers internal control relevant to the Group's preparation and presentation of the Consolidated Financial Statements that give a true and fair view, in order to design audit procedures that are appropriate in the circumstances, but not for the purpose of expressing an opinion on the effectiveness of the Group's internal control. An audit also includes evaluating the appropriateness of accounting policies used, the reasonableness of accounting estimates made by the Board of Directors, as well as evaluating the overall presentation of the Consolidated Financial Statements.

We have obtained from the Board of Directors and the Company's officials the explanations and information necessary for performing our audit procedure and we believe that the audit evidence we have obtained is sufficient and appropriate to provide a basis for our opinion.

*Unqualified opinion*

In our opinion, the Consolidated Financial Statements of the Group as at 31 December 2015 give a true and fair view of the net consolidated equity and financial position, and of its results for the year then ended in accordance with the International Financial Reporting Standards as adopted by the European Union.

**Emphasis of matter paragraph**

Without qualifying our opinion, we wish to draw the attention to the information, included in the notes of the Consolidated Financial Statements related to operating in a regulated environment, which clarifies the specificities of the regulatory framework, tariffs and related accounting treatment. The information also clarifies the uncertainties related to the financial balances resulting from tariff settlement mechanisms which are still to be approved by the VREG.

Ghent, 23 March 2016

Ernst & Young Bedrijfsrevisoren BCVBA  
Statutory auditor  
represented by



Paul Eelen  
Partner

160188

**ANNEX 4**  
**BALANCE SHEET AND INCOME STATEMENT OF EACH GUARANTOR**

**1. IMEWO**

**1.1 Balance sheet as of 31 December 2016 and 2015 in accordance with the financial reporting framework applicable in Belgium ("BE-GAAP")**

<u>ASSETS (In thousand €)</u>	<u>Codes</u>	<u>TOTAL</u>	
		31/12/2016	31/12/2015
<b>I. Formation expenses</b>	<b>20</b>	--	--
<b><u>FIXED ASSETS</u></b>	<b><u>21/28</u></b>	<b><u>1,787,082</u></b>	<b><u>1,781,376</u></b>
<b>II. Intangible fixed assets</b>	<b>21</b>	<b>21,336</b>	<b>23,128</b>
<b>III. Tangible fixed assets</b>	<b>22/27</b>	<b>1,765,520</b>	<b>1,758,243</b>
A. Land and buildings	22	31,526	30,773
B. Plant, machinery and equipment	23	1,664,117	1,680,095
C. Furniture and vehicles	24	3,706	4,030
D. Leasing and other rights	25	--	--
E. Other tangible fixed assets	26	154	138
F. Assets under construction and advance payments	27	66,017	43,207
<b>IV. Financial fixed assets</b>	<b>28</b>	<b>226</b>	<b>5</b>
A. Affiliated enterprises	280/1	--	--
1. Participating interests	280	--	--
2. Amounts receivable	281	--	--
B. Other enterprises linked by participating interests:	282/3	226	5
1. Participating interests	282	226	5
2. Amounts receivable	283	--	--
C. Other financial assets	284/8	--	--
1. Shares	284	--	--
2. Amounts receivable and cash guarantees	285/8	--	--
<b><u>CURRENT ASSETS</u></b>	<b><u>29/58</u></b>	<b><u>390,322</u></b>	<b><u>400,585</u></b>
<b>V. Amounts receivable after more than one year</b>	<b>29</b>	--	--
A. Trade debtors	290	--	--
B. Other amounts receivable	291	--	--
<b>VI. Stocks and contracts in progress</b>	<b>3</b>	<b>8,795</b>	<b>8,627</b>
A. Stocks	30/36	--	--

1. Raw materials and consumables	30/31	--	--
2. Work in progress	32	--	--
3. Finished goods	33	--	--
4. Goods purchased for resale	34	--	--
5. Immovable property intended for sale	35	--	--
6. Advance payments	36	--	--
B. Contracts in progress	37	8,795	8,627
<b>VII. Amounts receivable within one year</b>	<b>40/41</b>	<b>163,953</b>	<b>168,757</b>
A. Trade debtors	40	77,073	64,868
B. Other amounts receivable	41	86,880	103,889
<b>VIII. Current investments</b>	<b>50/53</b>	<b>--</b>	<b>--</b>
A. Own shares	50	--	--
B. Other investments and deposits	51/53	--	--
<b>IX. Cash at bank and in hand</b>	<b>54/58</b>	<b>3</b>	<b>3</b>
<b>X. Deferred charges and accrued income</b>	<b>490/1</b>	<b>217,571</b>	<b>223,198</b>
<b><u>TOTAL ASSETS</u></b>	<b><u>20/58</u></b>	<b><u>2,177,404</u></b>	<b><u>2,181,961</u></b>

<b><u>EQUITY AND LIABILITIES (In thousand €)</u></b>	<b><u>Codes</u></b>	<b><u>TOTAL</u></b>	
		<b>31/12/2016</b>	<b>31/12/2015</b>
<b><u>EQUITY</u></b>	<b><u>10/15</u></b>	<b><u>612,308</u></b>	<b><u>606,576</u></b>
<b>I. Capital</b>	<b>10</b>	<b>257,170</b>	<b>257,868</b>
A. Issued capital	100	257,170	257,868
B. Uncalled capital (-)	101	--	--
<b>II. Share premium account</b>	<b>11</b>	<b>--</b>	<b>--</b>
<b>III. Revaluation surpluses</b>	<b>12</b>	<b>180,488</b>	<b>188,353</b>
<b>IV. Reserves</b>	<b>13</b>	<b>159,678</b>	<b>145,337</b>
A. Legal reserve	130	25	25
B. Reserves not available	131	15,752	7,887
1. In respect of own shares held	1310	--	--
2. Other	1311	15,752	7,887
C. Untaxed reserves	132	--	--
D. Available reserves	133	143,901	137,425
<b>V. Accumulated profits</b>	<b>140</b>	<b>14,971</b>	<b>15,018</b>

Accumulated (losses)	141	--	--
<b>V. bis Result of the year</b>		--	--
<b>VI. Investment grants</b>	15	--	--
Advance to associates on the sharing out of the assets	19	--	--
<b><u>PROVISIONS AND DEFERRED TAXES</u></b>	<b>16</b>	<b>3,558</b>	<b>3,664</b>
<b>VII. A. Provisions for liabilities and charges</b>	<b>160/5</b>	<b>3,558</b>	<b>3,664</b>
1. Pensions and similar obligations	160	--	--
2. Taxation	161	--	--
3. Major repairs and maintenance	162	--	--
4. Environmental liabilities	163	2,269	2,269
5. Other risks and costs	164/5	1,289	1,395
<b>B. Deferred taxes</b>	<b>168</b>	<b>--</b>	<b>--</b>
<b><u>AMOUNTS PAYABLE</u></b>	<b>17/49</b>	<b>1,561,538</b>	<b>1,571,721</b>
<b>VII. Amounts payable after more than one year</b>	<b>17</b>	<b>1,227,316</b>	<b>1,217,272</b>
A. Financial debts	170/4	1,227,316	1,217,272
1. Subordinated loans	170	--	--
2. Unsubordinated debentures	171	--	--
3. Leasing and other similar obligations	172	--	--
4. Credit institutions	173	1,227,316	1,217,272
5. Other loans	174	--	--
B. Trade debts	175	--	--
1. Suppliers	1750	--	--
2. Bills of exchange payable	1751	--	--
C. Advances received on contracts in progress	176	--	--
D. Other amounts payable	178/9	--	--
<b>IX. Amounts payable within one year</b>	<b>42/48</b>	<b>241,476</b>	<b>273,374</b>
A. Current portion of amounts payable after more than one year falling due within one year	42	85,277	140,019
B. Financial debts	43	24,060	23,405
1. Credit institutions	430/8	--	--
2. Other loans	439	24,060	23,405
C. Trade debts	44	56,981	57,056
1. Suppliers	440/4	56,981	57,056
2. Bills of exchange payable	441	--	--
D. Advances received on contracts in progress	46	13,877	12,928
E. Taxes, remuneration and social security	45	40,452	21,505
1. Taxes	450/3	40,452	21,505
2. Remuneration and social security	454/9	--	--
F. Other amounts payable	47/48	20,829	18,461
<b>X. Accrued charges and deferred income</b>	<b>492/3</b>	<b>92,746</b>	<b>81,075</b>



<b><u>TOTAL LIABILITIES</u></b>	<b><u>10/49</u></b>	<b><u>2,177,404</u></b>	<b><u>2,181,961</u></b>

## 1.2 Income Statement BE-GAAP for the financial years ended 31 December 2016 and 2015

<b><u>CHARGES (In thousand €)</u></b>	<b><u>Codes</u></b>	<b><u>TOTAL</u></b>	
		<b>31/12/2016</b>	<b>31/12/2015</b>
<b><u>II. Operating charges</u></b>	<b><u>60/66A</u></b>	<b><u>410,993</u></b>	<b><u>445,494</u></b>
A. Raw materials, consumables	60	199,560	202,711
1. Purchases	600/8	199,560	202,711
2. Decrease (increase) in stocks (+)/(-)	609	--	--
B. Services and other goods	61	128,899	155,019
C. Remuneration, social security costs and pensions	62	--	--
D. Depreciation of and amounts written off formation expenses, intangible and tangible fixed assets	630	73,022	74,940
E. Increase, Decrease in amounts written off stocks contracts in progress and trade debtors:			
Appropriations (write-backs) (+)/(-)	631/4	-379	-1,243
F. Provisions for risks and charges - Appropriation (uses and write backs) (+)/(-)	635/8	-106	-128
G. Other operating charges	640/8	9,997	14,195
H. Operation charges carried to assets as restructuring costs (-)	649/6690	--	--
I. Non-recurring operating charges	66A	--	--
<b><u>III. Operating profit</u></b>	<b><u>9901</u></b>	<b><u>115,578</u></b>	<b><u>116,506</u></b>
<b><u>V. Financial charges</u></b>	<b><u>65/66B</u></b>	<b><u>44,489</u></b>	<b><u>46,680</u></b>
A. Recurring financial charges	65	44,489	46,680
1. Debt charges	650	44,473	46,653
2. Amounts written down on current assets except stocks, contracts in progress and trade debtors (+)/(-)	651	--	--
3. Other financial charges	652/9	16	27
B. Non recurring financial charges	66B	--	--
<b><u>VI. Profit for the period before taxes</u></b>	<b><u>9903</u></b>	<b><u>71,230</u></b>	<b><u>70,333</u></b>
<b><u>VII.B. Transfer to postponed taxes</u></b>	<b><u>680</u></b>	<b><u>--</u></b>	<b><u>--</u></b>
<b><u>VIII. Income taxes</u></b>			
A. Income taxes	<b><u>670/3</u></b>	<b><u>24,437</u></b>	<b><u>23,963</u></b>
	-	-	-
<b><u>IX. Profit for the period</u></b>	<b><u>9904</u></b>	<b><u>47,076</u></b>	<b><u>46,370</u></b>

	<b>TOTAL</b>	<b>60/67</b>	<b>526,995</b>	<b>562,507</b>
<b><u>X.B. Transfer to untaxed reserves</u></b>		<b>689</b>	<b>--</b>	<b>--</b>
<b><u>XI. Profit for the period available for appropriation</u></b>		<b>9905</b>	<b>47,076</b>	<b>46,370</b>

<b><u>INCOME (In thousand €)</u></b>	<b><u>Codes</u></b>	<b><u>TOTAL</u></b>	
		<b><u>31/12/2016</u></b>	<b><u>31/12/2015</u></b>
<b><u>I. Operating income</u></b>	<b><u>70/76A</u></b>	<b><u>526,571</u></b>	<b><u>562,000</u></b>
A. Turnover	70	510,380	544,175
B. Increase (decrease) in stocks of finished goods, work and contracts in progress (+)/(-)	71	169	-59
C. Own construction capitalised	72	--	--
D. Other operating income	74	16,022	17,884
E. Non-recurring operating income	76A	--	--
<b><u>III. Operating loss</u></b>	<b><u>9901</u></b>	<b><u>--</u></b>	<b><u>--</u></b>
<b><u>IV. Financial income</u></b>	<b><u>75/76B</u></b>	<b><u>141</u></b>	<b><u>507</u></b>
A. Recurring financial income	75	141	507
1. Income from financial fixed assets	750	--	--
2. Income from current assets	751	18	142
3. Other financial income	752/9	123	365
B. Non-recurring financial income	76B	--	--
<b><u>VI. Loss for the period before taxes</u></b>	<b><u>9903</u></b>	<b><u>--</u></b>	<b><u>--</u></b>
<b><u>VII.A. Transfer from postponed taxes</u></b>	<b><u>780</u></b>	<b><u>--</u></b>	<b><u>--</u></b>
<b><u>VIII. Income taxes</u></b>			
B. Adjustment of income taxes and write-back of tax provisions	<b><u>77</u></b>	<b><u>283</u></b>	<b><u>--</u></b>
<b><u>IX. Loss for the period</u></b>	<b><u>9904</u></b>	<b><u>--</u></b>	<b><u>--</u></b>
	<b>TOTAL</b>	<b>526,995</b>	<b>562,507</b>
<b><u>X.A. Transfer from untaxed reserves</u></b>	<b><u>789</u></b>	<b><u>--</u></b>	<b><u>--</u></b>
<b><u>XI. Loss for the period available for appropriation</u></b>	<b><u>9905</u></b>	<b><u>--</u></b>	<b><u>--</u></b>

## 2. Intergem

### 2.1 Balance sheet BE-GAAP as of 31 December 2016 and 2015

<u>ASSETS (In thousand €)</u>	<u>Codes</u>	<u>TOTAL</u>	
		<u>31/12/2016</u>	<u>31/12/2015</u>
<b>I. Formation expenses</b>	<b>20</b>	--	--
<b><u>FIXED ASSETS</u></b>	<b><u>21/28</u></b>	<b><u>845,106</u></b>	<b><u>851,128</u></b>
<b>II. Intangible fixed assets</b>	<b>21</b>	<b>10,647</b>	<b>11,644</b>
<b>III. Tangible fixed assets</b>	<b>22/27</b>	<b>834,349</b>	<b>839,482</b>
A. Land and buildings	22	24,372	24,461
B. Plant, machinery and equipment	23	785,296	801,851
C. Furniture and vehicles	24	2,425	2,164
D. Leasing and other rights	25	--	--
E. Other tangible fixed assets	26	18	26
F. Assets under construction and advance payments	27	22,238	10,980
<b>IV. Financial fixed assets</b>	<b>28</b>	<b>110</b>	<b>2</b>
A. Affiliated enterprises	280/1	--	--
1. Participating interests	280	--	--
2. Amounts receivable	281	--	--
B. Other enterprises linked by participating interests:	282/3	110	2
1. Participating interests	282	110	2
2. Amounts receivable	283	--	--
C. Other financial assets	284/8	--	--
1. Shares	284	--	--
2. Amounts receivable and cash guarantees	285/8	--	--
<b><u>CURRENT ASSETS</u></b>	<b><u>29/58</u></b>	<b><u>189,325</u></b>	<b><u>156,542</u></b>
<b>V. Amounts receivable after more than one year</b>	<b>29</b>	<b>93</b>	<b>117</b>
A. Trade debtors	290	93	117
B. Other amounts receivable	291	--	--
<b>VI. Stocks and contracts in progress</b>	<b>3</b>	<b>5,115</b>	<b>5,082</b>
A. Stocks	30/36	--	--
1. Raw materials and consumables	30/31	--	--
2. Work in progress	32	--	--
3. Finished goods	33	--	--

4. Goods purchased for resale	34	--	--
5. Immovable property intended for sale	35	--	--
6. Advance payments	36	--	--
B. Contracts in progress	37	5,115	5,082
<b>VII. Amounts receivable within one year</b>	<b>40/41</b>	<b>112,045</b>	<b>114,218</b>
A. Trade debtors	40	40,130	32,410
B. Other amounts receivable	41	71,915	81,808
<b>VIII. Current investments</b>	<b>50/53</b>	<b>--</b>	<b>--</b>
A. Own shares	50	--	--
B. Other investments and deposits	51/53	--	--
<b>IX. Cash at bank and in hand</b>	<b>54/58</b>	<b>2</b>	<b>3</b>
<b>X. Deferred charges and accrued income</b>	<b>490/1</b>	<b>72,070</b>	<b>37,122</b>
<b><u>TOTAL ASSETS</u></b>	<b><u>20/58</u></b>	<b><u>1,034,431</u></b>	<b><u>1,007,670</u></b>

<b><u>EQUITY AND LIABILITIES (In thousand €)</u></b>	<b><u>Codes</u></b>	<b><u>TOTAL</u></b>	
		<b>31/12/2016</b>	<b>31/12/2015</b>
<b><u>EQUITY</u></b>	<b><u>10/15</u></b>	<b><u>290,395</u></b>	<b><u>286,687</u></b>
<b>I. Capital</b>	<b>10</b>	<b>97,527</b>	<b>97,961</b>
A. Issued capital	100	97,527	97,961
B. Uncalled capital (-)	101	--	--
<b>II. Share premium account</b>	<b>11</b>	<b>--</b>	<b>--</b>
<b>III. Revaluation surpluses</b>	<b>12</b>	<b>96,592</b>	<b>101,252</b>
<b>IV. Reserves</b>	<b>13</b>	<b>87,826</b>	<b>78,962</b>
A. Legal reserve	130	35	35
B. Reserves not available	131	9,330	4,670
1. In respect of own shares held	1310	--	--
2. Other	1311	9,330	4,670
C. Untaxed reserves	132	--	--
D. Available reserves	133	78,461	74,257
<b>V. Accumulated profits</b>	<b>140</b>	<b>8,450</b>	<b>8,512</b>
<b>Accumulated (losses)</b>	<b>141</b>	<b>--</b>	<b>--</b>
<b>V. bis Result of the year</b>		<b>--</b>	<b>--</b>
<b>VI. Investment grants</b>	<b>15</b>	<b>--</b>	<b>--</b>

Advance to associates on the sharing out of the assets	19	--	--
<b>PROVISIONS AND DEFERRED TAXES</b>	<b>16</b>	<b>3,320</b>	<b>3,432</b>
<b>VII. A. Provisions for liabilities and charges</b>	<b>160/5</b>	<b>3,320</b>	<b>3,432</b>
1. Pensions and similar obligations	160	--	--
2. Taxation	161	--	--
3. Major repairs and maintenance	162	--	--
4. Environmental liabilities	163	2,679	2,728
5. Other risks and costs	164/5	641	704
<b>B. Deferred taxes</b>	<b>168</b>	<b>--</b>	<b>--</b>
<b>AMOUNTS PAYABLE</b>	<b>17/49</b>	<b>740,716</b>	<b>717,551</b>
<b>VII. Amounts payable after more than one year</b>	<b>17</b>	<b>532,076</b>	<b>520,807</b>
A. Financial debts	170/4	532,076	520,807
1. Subordinated loans	170	--	--
2. Unsubordinated debentures	171	--	--
3. Leasing and other similar obligations	172	--	--
4. Credit institutions	173	532,076	520,807
5. Other loans	174	--	--
B. Trade debts	175	--	--
1. Suppliers	1750	--	--
2. Bills of exchange payable	1751	--	--
C. Advances received on contracts in progress	176	--	--
D. Other amounts payable	178/9	--	--
<b>IX. Amounts payable within one year</b>	<b>42/48</b>	<b>153,689</b>	<b>168,627</b>
A. Current portion of amounts payable after more than one year falling due within one year	42	40,451	93,737
B. Financial debts	43	49,532	22,178
1. Credit institutions	430/8	--	--
2. Other loans	439	49,532	22,178
C. Trade debts	44	28,593	28,605
1. Suppliers	440/4	28,593	28,605
2. Bills of exchange payable	441	--	--
D. Advances received on contracts in progress	46	8,126	7,712
E. Taxes, remuneration and social security	45	19,984	10,472
1. Taxes	450/3	19,984	10,472
2. Remuneration and social security	454/9	--	--
F. Other amounts payable	47/48	7,003	5,923
<b>X. Accrued charges and deferred income</b>	<b>492/3</b>	<b>54,951</b>	<b>28,117</b>
<b>TOTAL LIABILITIES</b>	<b>10/49</b>	<b>1,034,431</b>	<b>1,007,670</b>

## 2.2 Income statement BE-GAAP for the financial years ended 31 December 2016 and 2015

<u>CHARGES (In thousand €)</u>	<u>Codes</u>	<u>TOTAL</u>	
		<u>31/12/2016</u>	<u>31/12/2015</u>
<b><u>II. Operating charges</u></b>	<b><u>60/66A</u></b>	<b><u>201,767</u></b>	<b><u>223,180</u></b>
A. Raw materials, consumables	60	102,315	102,846
1. Purchases	600/8	102,315	102,846
2. Decrease (increase) in stocks (+)/(-)	609	--	--
B. Services and other goods	61	60,491	79,304
C. Remuneration, social security costs and pensions	62	--	--
D. Depreciation of and amounts written off formation expenses, intangible and tangible fixed assets	630	35,345	35,575
E. Increase, Decrease in amounts written off stocks contracts in progress and trade debtors:			
Appropriations (write-backs) (+)/(-)	631/4	-225	821
F. Provisions for risks and charges - Appropriation (uses and write backs) (+)/(-)	635/8	-113	-299
G. Other operating charges	640/8	3,954	4,933
H. Operation charges carried to assets as restructuring costs (-)	649/6690	--	--
I. Non-recurring operating charges	66A	--	--
<b><u>III. Operating profit</u></b>	<b><u>9901</u></b>	<b><u>55,760</u></b>	<b><u>53,816</u></b>
<b><u>V. Financial charges</u></b>	<b><u>65/66B</u></b>	<b><u>20,597</u></b>	<b><u>21,079</u></b>
A. Recurring financial charges	65	20,597	21,079
1. Debt charges	650	20,587	21,064
2. Amounts written down on current assets except stocks, contracts in progress and trade debtors (+)/(-)	651	--	--
3. Other financial charges	652/9	10	15
B. Non recurring financial charges	66B	--	--
<b><u>VI. Profit for the period before taxes</u></b>	<b><u>9903</u></b>	<b><u>35,259</u></b>	<b><u>33,107</u></b>
<b><u>VII.B. Transfer to postponed taxes</u></b>	<b><u>680</u></b>	<b><u>--</u></b>	<b><u>--</u></b>
<b><u>VIII. Income taxes</u></b>			
A. Income taxes	<b><u>670/3</u></b>	<b><u>12,365</u></b>	<b><u>11,698</u></b>
	-	-	-
<b><u>IX. Profit for the period</u></b>	<b><u>9904</u></b>	<b><u>23,246</u></b>	<b><u>21,409</u></b>
<b>TOTAL</b>	<b><u>60/67</u></b>	<b><u>257,975</u></b>	<b><u>277,366</u></b>
<b><u>X.B. Transfer to untaxed reserves</u></b>	<b><u>689</u></b>	<b><u>--</u></b>	<b><u>--</u></b>

<b><u>XI. Profit for the period available for appropriation</u></b>	<b><u>9905</u></b>	<b><u>23,246</u></b>	<b><u>21,409</u></b>
---	--------------------	----------------------	----------------------

<b><u>INCOME (In thousand €)</u></b>	<b><u>Codes</u></b>	<b><u>TOTAL</u></b>	
		<b><u>31/12/2016</u></b>	<b><u>31/12/2015</u></b>
<b><u>I. Operating income</u></b>	<b><u>70/76A</u></b>	<b><u>257,527</u></b>	<b><u>276,996</u></b>
A. Turnover	70	248,121	265,253
B. Increase (decrease) in stocks of finished goods, work and contracts in progress (+)/(-)	71	33	978
C. Own construction capitalised	72	--	--
D. Other operating income	74	9,373	10,765
E. Non-recurring operating income	76A	--	--
<b><u>III. Operating loss</u></b>	<b><u>9901</u></b>	<b><u>--</u></b>	<b><u>--</u></b>
<b><u>IV. Financial income</u></b>	<b><u>75/76B</u></b>	<b><u>96</u></b>	<b><u>370</u></b>
A. Recurring financial income	75	96	370
1. Income from financial fixed assets	750	--	--
2. Income from current assets	751	1	90
3. Other financial income	752/9	95	280
B. Non-recurring financial income	76B	--	--
<b><u>VI. Loss for the period before taxes</u></b>	<b><u>9903</u></b>	<b><u>--</u></b>	<b><u>--</u></b>
<b><u>VII.A. Transfer from postponed taxes</u></b>	<b><u>780</u></b>	<b><u>--</u></b>	<b><u>--</u></b>
<b><u>VIII. Income taxes</u></b>			
B. Adjustment of income taxes and write-back of tax provisions	<b><u>77</u></b>	<b><u>352</u></b>	<b><u>--</u></b>
<b><u>IX. Loss for the period</u></b>	<b><u>9904</u></b>	<b><u>--</u></b>	<b><u>--</u></b>
<b>TOTAL</b>	<b><u>70/77</u></b>	<b><u>257,975</u></b>	<b><u>277,366</u></b>
<b><u>X.A. Transfer from untaxed reserves</u></b>	<b><u>789</u></b>	<b><u>--</u></b>	<b><u>--</u></b>
<b><u>XI. Loss for the period available for appropriation</u></b>	<b><u>9905</u></b>	<b><u>--</u></b>	<b><u>--</u></b>

### 3. IVEKA

#### 3.1 Balance sheet BE-GAAP as of 31 December 2016 and 2015

<u>ASSETS (In thousand €)</u>	<u>Codes</u>	<u>TOTAL</u>	
		31/12/2016	31/12/2015
<b>I. Formation expenses</b>	<b>20</b>	--	--
<b><u>FIXED ASSETS</u></b>	<b><u>21/28</u></b>	<b><u>1,102,225</u></b>	<b><u>1,103,338</u></b>
<b>II. Intangible fixed assets</b>	<b>21</b>	<b>13,849</b>	<b>15,028</b>
<b>III. Tangible fixed assets</b>	<b>22/27</b>	<b>1,088,231</b>	<b>1,088,307</b>
A. Land and buildings	22	26,193	25,922
B. Plant, machinery and equipment	23	1,024,290	1,039,041
C. Furniture and vehicles	24	2,737	3,378
D. Leasing and other rights	25	--	--
E. Other tangible fixed assets	26	24	23
F. Assets under construction and advance payments	27	34,987	19,943
<b>IV. Financial fixed assets</b>	<b>28</b>	<b>145</b>	<b>3</b>
A. Affiliated enterprises	280/1	--	--
1. Participating interests	280	--	--
2. Amounts receivable	281	--	--
B. Other enterprises linked by participating interests:	282/3	145	3
1. Participating interests	282	145	3
2. Amounts receivable	283	--	--
C. Other financial assets	284/8	0	0
1. Shares	284	--	--
2. Amounts receivable and cash guarantees	285/8	0	0
<b><u>CURRENT ASSETS</u></b>	<b><u>29/58</u></b>	<b><u>380,849</u></b>	<b><u>373,538</u></b>
<b>V. Amounts receivable after more than one year</b>	<b>29</b>	<b>116</b>	<b>152</b>
A. Trade debtors	290	116	152
B. Other amounts receivable	291	--	--
<b>VI. Stocks and contracts in progress</b>	<b>3</b>	<b>12,567</b>	<b>14,382</b>
A. Stocks	30/36	--	--
1. Raw materials and consumables	30/31	--	--
2. Work in progress	32	--	--
3. Finished goods	33	--	--
4. Goods purchased for resale	34	--	--
5. Immovable property intended for sale	35	--	--



6. Advance payments	36	--	--
B. Contracts in progress	37	12,567	14,382
<b>VII. Amounts receivable within one year</b>	<b>40/41</b>	<b>199,362</b>	<b>189,709</b>
A. Trade debtors	40	60,944	43,259
B. Other amounts receivable	41	138,418	146,450
<b>VIII. Current investments</b>	<b>50/53</b>	<b>--</b>	<b>--</b>
A. Own shares	50	--	--
B. Other investments and deposits	51/53	--	--
<b>IX. Cash at bank and in hand</b>	<b>54/58</b>	<b>3</b>	<b>3</b>
<b>X. Deferred charges and accrued income</b>	<b>490/1</b>	<b>168,801</b>	<b>169,292</b>
<b><u>TOTAL ASSETS</u></b>	<b><u>20/58</u></b>	<b><u>1,483,074</u></b>	<b><u>1,476,876</u></b>

<b><u>EQUITY AND LIABILITIES (In thousand €)</u></b>	<b><u>Codes</u></b>	<b><u>TOTAL</u></b>	
		<b>31/12/2016</b>	<b>31/12/2015</b>
<b><u>EQUITY</u></b>	<b><u>10/15</u></b>	<b><u>408,031</u></b>	<b><u>434,186</u></b>
<b>I. Capital</b>	<b>10</b>	<b>186,138</b>	<b>199,230</b>
A. Issued capital	100	186,138	199,230
B. Uncalled capital (-)	101	--	--
<b>II. Share premium account</b>	<b>11</b>	<b>--</b>	<b>--</b>
<b>III. Revaluation surpluses</b>	<b>12</b>	<b>107,471</b>	<b>112,738</b>
<b>IV. Reserves</b>	<b>13</b>	<b>107,245</b>	<b>114,982</b>
A. Legal reserve	130	98	98
B. Reserves not available	131	10,411	5,144
1. In respect of own shares held	1310	--	--
2. Other	1311	10,411	5,144
C. Untaxed reserves	132	--	--
D. Available reserves	133	96,736	109,740
<b>V. Accumulated profits</b>	<b>140</b>	<b>7,177</b>	<b>7,236</b>
Accumulated (losses)	<b>141</b>	<b>--</b>	<b>--</b>
<b>V. bis Result of the year</b>		<b>--</b>	<b>--</b>
<b>VI. Investment grants</b>	<b>15</b>	<b>--</b>	<b>--</b>

Advance to associates on the sharing out of the assets	19	--	--
<b><u>PROVISIONS AND DEFERRED TAXES</u></b>	<b><u>16</u></b>	<b><u>2,545</u></b>	<b><u>2,604</u></b>
<b>VII. A. Provisions for liabilities and charges</b>	<b>160/5</b>	<b>2,545</b>	<b>2,604</b>
1. Pensions and similar obligations	160	--	--
2. Taxation	161	--	--
3. Major repairs and maintenance	162	--	--
4. Environmental liabilities	163	1,282	1,282
5. Other risks and costs	164/5	1,263	1,322
<b>B. Deferred taxes</b>	<b>168</b>	<b>--</b>	<b>--</b>
<b><u>AMOUNTS PAYABLE</u></b>	<b><u>17/49</u></b>	<b><u>1,072,498</u></b>	<b><u>1,040,086</u></b>
<b>VII. Amounts payable after more than one year</b>	<b>17</b>	<b>779,912</b>	<b>776,382</b>
A. Financial debts	170/4	779,912	776,382
1. Subordinated loans	170	--	--
2. Unsubordinated debentures	171	--	--
3. Leasing and other similar obligations	172	--	--
4. Credit institutions	173	779,912	776,382
5. Other loans	174	--	--
B. Trade debts	175	--	--
1. Suppliers	1750	--	--
2. Bills of exchange payable	1751	--	--
C. Advances received on contracts in progress	176	--	--
D. Other amounts payable	178/9	--	--
<b>IX. Amounts payable within one year</b>	<b>42/48</b>	<b>232,327</b>	<b>222,755</b>
A. Current portion of amounts payable after more than one year falling due within one year	42	50,270	104,468
B. Financial debts	43	85,221	35,954
1. Credit institutions	430/8	--	--
2. Other loans	439	85,221	35,954
C. Trade debts	44	42,760	41,715
1. Suppliers	440/4	42,760	41,715
2. Bills of exchange payable	441	--	--
D. Advances received on contracts in progress	46	11,996	14,028
E. Taxes, remuneration and social security	45	27,269	14,512
1. Taxes	450/3	27,269	14,512
2. Remuneration and social security	454/9	--	--
F. Other amounts payable	47/48	14,811	12,078
<b>X. Accrued charges and deferred income</b>	<b>492/3</b>	<b>60,259</b>	<b>40,949</b>
<b><u>TOTAL LIABILITIES</u></b>	<b><u>10/49</u></b>	<b><u>1,483,074</u></b>	<b><u>1,476,876</u></b>

### 3.2 Income statement BE-GAAP for the financial years ended 31 December 2016 and 2015

<u>CHARGES (In thousand €)</u>	<u>Codes</u>	<u>TOTAL</u>	
		<u>31/12/2016</u>	<u>31/12/2015</u>
<b><u>II. Operating charges</u></b>	<b><u>60/66A</u></b>	<b><u>296,050</u></b>	<b><u>322,734</u></b>
A. Raw materials, consumables	60	155,915	157,524
1. Purchases	600/8	155,915	157,524
2. Decrease (increase) in stocks (+)/(-)	609	--	--
B. Services and other goods	61	87,508	109,768
C. Remuneration, social security costs and pensions	62	--	--
D. Depreciation of and amounts written off formation expenses, intangible and tangible fixed assets	630	46,954	48,007
E. Increase, Decrease in amounts written off stocks contracts in progress and trade debtors:			
Appropriations (write-backs) (+)/(-)	631/4	-1,245	218
F. Provisions for risks and charges - Appropriation (uses and write backs) (+)/(-)	635/8	-59	-61
G. Other operating charges	640/8	6,977	7,278
H. Operation charges carried to assets as restructuring costs (-)	649/6690	--	--
I. Non-recurring operating charges	66A	--	--
<b><u>III. Operating profit</u></b>	<b><u>9901</u></b>	<b><u>75,944</u></b>	<b><u>76,126</u></b>
<b><u>V. Financial charges</u></b>	<b><u>65/66B</u></b>	<b><u>28,695</u></b>	<b><u>29,512</u></b>
A. Recurring financial charges	65	28,695	29,512
1. Debt charges	650	28,695	29,511
2. Amounts written down on current assets except stocks, contracts in progress and trade debtors (+)/(-)	651	--	--
3. Other financial charges	652/9	-0	1
B. Non recurring financial charges	66B	--	--
<b><u>VI. Profit for the period before taxes</u></b>	<b><u>9903</u></b>	<b><u>47,391</u></b>	<b><u>47,125</u></b>
<b><u>VII.B. Transfer to postponed taxes</u></b>	<b><u>680</u></b>	<b><u>--</u></b>	<b><u>--</u></b>
<b><u>VIII. Income taxes</u></b>			
A. Income taxes	<b><u>670/3</u></b>	<b><u>16,406</u></b>	<b><u>16,002</u></b>
	-	-	-
<b><u>IX. Profit for the period</u></b>	<b><u>9904</u></b>	<b><u>31,010</u></b>	<b><u>31,123</u></b>
<b>TOTAL</b>	<b><u>60/67</u></b>	<b><u>372,162</u></b>	<b><u>399,371</u></b>
<b><u>X.B. Transfer to untaxed reserves</u></b>	<b><u>689</u></b>	<b><u>--</u></b>	<b><u>--</u></b>

<b><u>XI. Profit for the period available for appropriation</u></b>	<b><u>9905</u></b>	<b><u>31,010</u></b>	<b><u>31,123</u></b>
---	--------------------	----------------------	----------------------

<b><u>INCOME (In thousand €)</u></b>	<b><u>Codes</u></b>	<b><u>TOTAL</u></b>	
		<b><u>31/12/2016</u></b>	<b><u>31/12/2015</u></b>
<b><u>I. Operating income</u></b>	<b><u>70/76A</u></b>	<b><u>371,994</u></b>	<b><u>398,860</u></b>
A. Turnover	70	360,718	378,920
B. Increase (decrease) in stocks of finished goods, work and contracts in progress (+)/(-)	71	-1,814	5,236
C. Own construction capitalised	72	--	--
D. Other operating income	74	13,090	14,704
E. Non-recurring operating income	76A	--	--
<b><u>III. Operating loss</u></b>	<b><u>9901</u></b>	<b><u>--</u></b>	<b><u>--</u></b>
<b><u>IV. Financial income</u></b>	<b><u>75/76B</u></b>	<b><u>142</u></b>	<b><u>511</u></b>
A. Recurring financial income	75	142	511
1. Income from financial fixed assets	750	--	--
2. Income from current assets	751	9	101
3. Other financial income	752/9	133	410
B. Non-recurring financial income	76B	--	--
<b><u>VI. Loss for the period before taxes</u></b>	<b><u>9903</u></b>	<b><u>--</u></b>	<b><u>--</u></b>
<b><u>VII.A. Transfer from postponed taxes</u></b>	<b><u>780</u></b>	<b><u>=</u></b>	<b><u>=</u></b>
<b><u>VIII. Income taxes</u></b>			
B. Adjustment of income taxes and write-back of tax provisions	<u>77</u>	<u>25</u>	=
<b><u>IX. Loss for the period</u></b>	<b><u>9904</u></b>	<b><u>=</u></b>	<b><u>=</u></b>
<b>TOTAL</b>	<b>70/77</b>	<b>372,162</b>	<b>399,371</b>
<b><u>X.A. Transfer from untaxed reserves</u></b>	<b><u>789</u></b>	<b><u>=</u></b>	<b><u>=</u></b>
<b><u>XI. Loss for the period available for appropriation</u></b>	<b><u>9905</u></b>	<b><u>=</u></b>	<b><u>=</u></b>

#### 4. IVERLEK

##### 4.1 Balance sheet BE-GAAP as of 31 December 2016 and 2015

<u>ASSETS (In thousand €)</u>	<u>Codes</u>	<u>TOTAL</u>	
		31/12/2016	31/12/2015
<b>I. Formation expenses</b>	<b>20</b>	--	--
<b><u>FIXED ASSETS</u></b>	<b><u>21/28</u></b>	<b><u>1,561,548</u></b>	<b><u>1,552,300</u></b>
<b>II. Intangible fixed assets</b>	<b>21</b>	<b>18,855</b>	<b>20,594</b>
<b>III. Tangible fixed assets</b>	<b>22/27</b>	<b>1,542,497</b>	<b>1,531,702</b>
A. Land and buildings	22	39,137	38,613
B. Plant, machinery and equipment	23	1,439,936	1,456,132
C. Furniture and vehicles	24	4,725	5,152
D. Leasing and other rights	25	--	--
E. Other tangible fixed assets	26	43	58
F. Assets under construction and advance payments	27	58,656	31,747
<b>IV. Financial fixed assets</b>	<b>28</b>	<b>196</b>	<b>4</b>
A. Affiliated enterprises	280/1	--	--
1. Participating interests	280	--	--
2. Amounts receivable	281	--	--
B. Other enterprises linked by participating interests:	282/3	196	4
1. Participating interests	282	196	4
2. Amounts receivable	283	--	--
C. Other financial assets	284/8	--	--
1. Shares	284	--	--
2. Amounts receivable and cash guarantees	285/8	--	--
<b><u>CURRENT ASSETS</u></b>	<b><u>29/58</u></b>	<b><u>353,430</u></b>	<b><u>368,252</u></b>
<b>V. Amounts receivable after more than one year</b>	<b>29</b>	<b>93</b>	<b>121</b>
A. Trade debtors	290	93	121
B. Other amounts receivable	291	--	--
<b>VI. Stocks and contracts in progress</b>	<b>3</b>	<b>8,541</b>	<b>8,831</b>
A. Stocks	30/36	--	--
1. Raw materials and consumables	30/31	--	--
2. Work in progress	32	--	--
3. Finished goods	33	--	--
4. Goods purchased for resale	34	--	--
5. Immovable property intended for sale	35	--	--

6. Advance payments	36	--	--
B. Contracts in progress	37	8,541	8,831
<b>VII. Amounts receivable within one year</b>	<b>40/41</b>	<b>154,733</b>	<b>158,432</b>
A. Trade debtors	40	69,518	57,064
B. Other amounts receivable	41	85,215	101,368
<b>VIII. Current investments</b>	<b>50/53</b>	<b>--</b>	<b>--</b>
A. Own shares	50	--	--
B. Other investments and deposits	51/53	--	--
<b>IX. Cash at bank and in hand</b>	<b>54/58</b>	<b>30</b>	<b>3</b>
<b>X. Deferred charges and accrued income</b>	<b>490/1</b>	<b>190,033</b>	<b>200,865</b>
<b><u>TOTAL ASSETS</u></b>	<b><u>20/58</u></b>	<b><u>1,914,978</u></b>	<b><u>1,920,552</u></b>

<b><u>EQUITY AND LIABILITIES (In thousand €)</u></b>	<b><u>Codes</u></b>	<b><u>TOTAL</u></b>	
		<b>31/12/2016</b>	<b>31/12/2015</b>
<b><u>EQUITY</u></b>	<b><u>10/15</u></b>	<b><u>591,152</u></b>	<b><u>585,964</u></b>
<b>I. Capital</b>	<b>10</b>	<b>254,084</b>	<b>254,084</b>
A. Issued capital	100	254,084	254,084
B. Uncalled capital (-)	101	--	--
<b>II. Share premium account</b>	<b>11</b>	<b>--</b>	<b>--</b>
<b>III. Revaluation surpluses</b>	<b>12</b>	<b>152,651</b>	<b>159,712</b>
<b>IV. Reserves</b>	<b>13</b>	<b>171,855</b>	<b>159,743</b>
A. Legal reserve	130	45	45
B. Reserves not available	131	14,129	7,068
1. In respect of own shares held	1310	--	--
2. Other	1311	14,129	7,068
C. Untaxed reserves	132	--	--
D. Available reserves	133	157,681	152,630
<b>V. Accumulated profits</b>	<b>140</b>	<b>12,407</b>	<b>12,425</b>
Accumulated (losses)	<b>141</b>	<b>--</b>	<b>--</b>
<b>V. bis Result of the year</b>		<b>--</b>	<b>--</b>
<b>VI. Investment grants</b>	<b>15</b>	<b>155</b>	<b>--</b>

Advance to associates on the sharing out of the assets	19	--	--
<b><u>PROVISIONS AND DEFERRED TAXES</u></b>	<b><u>16</u></b>	<b><u>1,671</u></b>	<b><u>2,053</u></b>
<b>VII. A. Provisions for liabilities and charges</b>	<b>160/5</b>	<b>1,591</b>	<b>2,053</b>
1. Pensions and similar obligations	160	--	--
2. Taxation	161	--	--
3. Major repairs and maintenance	162	--	--
4. Environmental liabilities	163	44	62
5. Other risks and costs	164/5	1,547	1,991
<b>B. Deferred taxes</b>	<b>168</b>	<b>80</b>	<b>--</b>
<b><u>AMOUNTS PAYABLE</u></b>	<b><u>17/49</u></b>	<b><u>1,322,155</u></b>	<b><u>1,332,535</u></b>
<b>VII. Amounts payable after more than one year</b>	<b>17</b>	<b>1,049,959</b>	<b>1,041,193</b>
A. Financial debts	170/4	1,049,959	1,041,193
1. Subordinated loans	170	--	--
2. Unsubordinated debentures	171	--	--
3. Leasing and other similar obligations	172	--	--
4. Credit institutions	173	1,049,959	1,041,193
5. Other loans	174	--	--
B. Trade debts	175	--	--
1. Suppliers	1750	--	--
2. Bills of exchange payable	1751	--	--
C. Advances received on contracts in progress	176	--	--
D. Other amounts payable	178/9	--	--
<b>IX. Amounts payable within one year</b>	<b>42/48</b>	<b>218,862</b>	<b>246,938</b>
A. Current portion of amounts payable after more than one year falling due within one year	42	67,714	128,722
B. Financial debts	43	33,523	19,631
1. Credit institutions	430/8	--	--
2. Other loans	439	33,523	19,631
C. Trade debts	44	56,739	55,484
1. Suppliers	440/4	56,739	55,484
2. Bills of exchange payable	441	--	--
D. Advances received on contracts in progress	46	11,140	12,081
E. Taxes, remuneration and social security	45	35,615	19,508
1. Taxes	450/3	35,615	19,508
2. Remuneration and social security	454/9	--	--
F. Other amounts payable	47/48	14,131	11,512
<b>X. Accrued charges and deferred income</b>	<b>492/3</b>	<b>53,334</b>	<b>44,404</b>
<b><u>TOTAL LIABILITIES</u></b>	<b><u>10/49</u></b>	<b><u>1,914,978</u></b>	<b><u>1,920,552</u></b>

#### 4.2 Income statement BE-GAAP for the financial years ended 31 December 2016 and 2015

<u>CHARGES (In thousand €)</u>	<u>Codes</u>	<u>TOTAL</u>	
		<u>31/12/2016</u>	<u>31/12/2015</u>
<b><u>II. Operating charges</u></b>	<b><u>60/66A</u></b>	<b><u>378,760</u></b>	<b><u>409,213</u></b>
A. Raw materials, consumables	60	189,607	190,229
1. Purchases	600/8	189,607	190,229
2. Decrease (increase) in stocks (+)/(-)	609	--	--
B. Services and other goods	61	116,500	143,146
C. Remuneration, social security costs and pensions	62	--	--
D. Depreciation of and amounts written off formation expenses, intangible and tangible fixed assets	630	64,603	66,957
E. Increase, Decrease in amounts written off stocks contracts in progress and trade debtors:			
Appropriations (write-backs) (+)/(-)	631/4	-793	-562
F. Provisions for risks and charges - Appropriation (uses and write backs) (+)/(-)	635/8	-462	-1,531
G. Other operating charges	640/8	9,305	10,974
H. Operation charges carried to assets as restructuring costs (-)	649/6690	--	--
I. Non-recurring operating charges	66A	--	--
<b><u>III. Operating profit</u></b>	<b><u>9901</u></b>	<b><u>101,053</u></b>	<b><u>103,555</u></b>
<b><u>V. Financial charges</u></b>	<b><u>65/66B</u></b>	<b><u>38,150</u></b>	<b><u>39,093</u></b>
A. Recurring financial charges	65	38,150	39,093
1. Debt charges	650	38,142	39,068
2. Amounts written down on current assets except stocks, contracts in progress and trade debtors (+)/(-)	651	--	--
3. Other financial charges	652/9	8	25
B. Non recurring financial charges	66B	--	--
<b><u>VI. Profit for the period before taxes</u></b>	<b><u>9903</u></b>	<b><u>63,052</u></b>	<b><u>64,864</u></b>
<b><u>VII.B. Transfer to postponed taxes</u></b>	<b><u>680</u></b>	<b><u>--</u></b>	<b><u>--</u></b>
<b><u>VIII. Income taxes</u></b>			
A. Income taxes	<u>670/3</u>	<u>21,399</u>	<u>21,622</u>
	-	-	-
<b><u>IX. Profit for the period</u></b>	<b><u>9904</u></b>	<b><u>42,136</u></b>	<b><u>43,242</u></b>
<b>TOTAL</b>	<b><u>60/67</u></b>	<b><u>480,444</u></b>	<b><u>513,170</u></b>
<b><u>X.B. Transfer to untaxed reserves</u></b>	<b><u>689</u></b>	<b><u>--</u></b>	<b><u>--</u></b>



<b><u>XI. Profit for the period available for appropriation</u></b>	<b><u>9905</u></b>	<b><u>42,136</u></b>	<b><u>43,242</u></b>
---	--------------------	----------------------	----------------------

<b><u>INCOME (In thousand €)</u></b>	<b><u>Codes</u></b>	<b><u>TOTAL</u></b>	
		<b><u>31/12/2016</u></b>	<b><u>31/12/2015</u></b>
<b><u>I. Operating income</u></b>	<b><u>70/76A</u></b>	<b><u>479,813</u></b>	<b><u>512,768</u></b>
A. Turnover	70	460,867	493,441
B. Increase (decrease) in stocks of finished goods, work and contracts in progress (+)/(-)	71	-289	524
C. Own construction capitalised	72	--	--
D. Other operating income	74	19,235	18,803
E. Non-recurring operating income	76A	--	--
<b><u>III. Operating loss</u></b>	<b><u>9901</u></b>	<b><u>--</u></b>	<b><u>--</u></b>
<b><u>IV. Financial income</u></b>	<b><u>75/76B</u></b>	<b><u>149</u></b>	<b><u>402</u></b>
A. Recurring financial income	75	149	402
1. Income from financial fixed assets	750	--	--
2. Income from current assets	751	25	68
3. Other financial income	752/9	124	334
B. Non-recurring financial income	76B	--	--
<b><u>VI. Loss for the period before taxes</u></b>	<b><u>9903</u></b>	<b><u>--</u></b>	<b><u>--</u></b>
<b><u>VII.A. Transfer from postponed taxes</u></b>	<b><u>780</u></b>	<b><u>--</u></b>	<b><u>--</u></b>
<b><u>VIII. Income taxes</u></b>			
B. Adjustment of income taxes and write-back of tax provisions	<b><u>77</u></b>	<b><u>483</u></b>	<b><u>--</u></b>
<b><u>IX. Loss for the period</u></b>	<b><u>9904</u></b>	<b><u>--</u></b>	<b><u>--</u></b>
<b>TOTAL</b>	<b><u>70/77</u></b>	<b><u>480,444</u></b>	<b><u>513,170</u></b>
<b><u>X.A. Transfer from untaxed reserves</u></b>	<b><u>789</u></b>	<b><u>--</u></b>	<b><u>--</u></b>
<b><u>XI. Loss for the period available for appropriation</u></b>	<b><u>9905</u></b>	<b><u>--</u></b>	<b><u>--</u></b>

## 5. Sibelgas

### 5.1 Balance sheet BE-GAAP as of 31 December 2016 and 2015

<u>ASSETS (In thousand €)</u>	<u>Codes</u>	<u>TOTAL</u>	
		31/12/2016	31/12/2015
<b>I. Formation expenses</b>	<b>20</b>	--	--
<b><u>FIXED ASSETS</u></b>	<b><u>21/28</u></b>	<b><u>192,823</u></b>	<b><u>193,568</u></b>
<b>II. Intangible fixed assets</b>	<b>21</b>	<b>2,405</b>	<b>2,567</b>
<b>III. Tangible fixed assets</b>	<b>22/27</b>	<b>190,393</b>	<b>190,994</b>
A. Land and buildings	22	1,539	1,718
B. Plant, machinery and equipment	23	175,904	181,024
C. Furniture and vehicles	24	502	610
D. Leasing and other rights	25	--	--
E. Other tangible fixed assets	26	7	4
F. Assets under construction and advance payments	27	12,441	7,638
<b>IV. Financial fixed assets</b>	<b>28</b>	<b>25</b>	<b>7</b>
A. Affiliated enterprises	280/1	--	--
1. Participating interests	280	--	--
2. Amounts receivable	281	--	--
B. Other enterprises linked by participating interests:	282/3	25	1
1. Participating interests	282	25	1
2. Amounts receivable	283	--	--
C. Other financial assets	284/8	--	6
1. Shares	284	--	--
2. Amounts receivable and cash guarantees	285/8	--	6
<b><u>CURRENT ASSETS</u></b>	<b><u>29/58</u></b>	<b><u>72,266</u></b>	<b><u>91,716</u></b>
<b>V. Amounts receivable after more than one year</b>	<b>29</b>	<b>281</b>	<b>351</b>
A. Trade debtors	290	281	351
B. Other amounts receivable	291	--	--
<b>VI. Stocks and contracts in progress</b>	<b>3</b>	<b>625</b>	<b>727</b>
A. Stocks	30/36	--	--
1. Raw materials and consumables	30/31	--	--
2. Work in progress	32	--	--
3. Finished goods	33	--	--
4. Goods purchased for resale	34	--	--
5. Immovable property intended for sale	35	--	--

6. Advance payments	36	--	--
B. Contracts in progress	37	625	727
<b>VII. Amounts receivable within one year</b>	<b>40/41</b>	<b>21,607</b>	<b>17,707</b>
A. Trade debtors	40	19,057	11,867
B. Other amounts receivable	41	2,550	5,840
<b>VIII. Current investments</b>	<b>50/53</b>	<b>--</b>	<b>--</b>
A. Own shares	50	--	--
B. Other investments and deposits	51/53	--	--
<b>IX. Cash at bank and in hand</b>	<b>54/58</b>	<b>1</b>	<b>1</b>
<b>X. Deferred charges and accrued income</b>	<b>490/1</b>	<b>49,752</b>	<b>72,930</b>
<b><u>TOTAL ASSETS</u></b>	<b><u>20/58</u></b>	<b><u>265,089</u></b>	<b><u>285,284</u></b>

<b><u>EQUITY AND LIABILITIES (In thousand €)</u></b>	<b><u>Codes</u></b>	<b><u>TOTAL</u></b>	
		<b>31/12/2016</b>	<b>31/12/2015</b>
<b><u>EQUITY</u></b>	<b><u>10/15</u></b>	<b><u>77,306</u></b>	<b><u>76,952</u></b>
<b>I. Capital</b>	<b>10</b>	<b>70,924</b>	<b>70,924</b>
A. Issued capital	100	70,924	70,924
B. Uncalled capital (-)	101	--	--
<b>II. Share premium account</b>	<b>11</b>	<b>--</b>	<b>--</b>
<b>III. Revaluation surpluses</b>	<b>12</b>	<b>--</b>	<b>--</b>
<b>IV. Reserves</b>	<b>13</b>	<b>3,693</b>	<b>3,289</b>
A. Legal reserve	130	25	25
B. Reserves not available	131	--	--
1. In respect of own shares held	1310	--	--
2. Other	1311	--	--
C. Untaxed reserves	132	--	--
D. Available reserves	133	3,668	3,264
<b>V. Accumulated profits</b>	<b>140</b>	<b>2,689</b>	<b>2,739</b>
Accumulated (losses)	<b>141</b>	<b>--</b>	<b>--</b>
<b>V. bis Result of the year</b>		<b>--</b>	<b>--</b>
<b>VI. Investment grants</b>	<b>15</b>	<b>--</b>	<b>--</b>

Advance to associates on the sharing out of the assets	19	--	--
<b><u>PROVISIONS AND DEFERRED TAXES</u></b>	<b><u>16</u></b>	<b><u>82</u></b>	<b><u>371</u></b>
<b>VII. A. Provisions for liabilities and charges</b>	<b>160/5</b>	<b>82</b>	<b>371</b>
1. Pensions and similar obligations	160	--	--
2. Taxation	161	--	--
3. Major repairs and maintenance	162	--	--
4. Environmental liabilities	163	--	--
5. Other risks and costs	164/5	82	371
<b>B. Deferred taxes</b>	<b>168</b>	<b>--</b>	<b>--</b>
<b><u>AMOUNTS PAYABLE</u></b>	<b><u>17/49</u></b>	<b><u>187,701</u></b>	<b><u>207,961</u></b>
<b>VII. Amounts payable after more than one year</b>	<b>17</b>	<b>125,528</b>	<b>124,104</b>
A. Financial debts	170/4	125,528	124,104
1. Subordinated loans	170	--	--
2. Unsubordinated debentures	171	--	--
3. Leasing and other similar obligations	172	--	--
4. Credit institutions	173	125,528	124,104
5. Other loans	174	--	--
B. Trade debts	175	--	--
1. Suppliers	1750	--	--
2. Bills of exchange payable	1751	--	--
C. Advances received on contracts in progress	176	--	--
D. Other amounts payable	178/9	--	--
<b>IX. Amounts payable within one year</b>	<b>42/48</b>	<b>37,861</b>	<b>59,446</b>
A. Current portion of amounts payable after more than one year falling due within one year	42	8,256	19,478
B. Financial debts	43	13,658	39
1. Credit institutions	430/8	--	--
2. Other loans	439	13,658	39
C. Trade debts	44	7,080	7,221
1. Suppliers	440/4	7,080	7,221
2. Bills of exchange payable	441	--	--
D. Advances received on contracts in progress	46	1,550	1,712
E. Taxes, remuneration and social security	45	3,610	2,416
1. Taxes	450/3	3,610	2,399
2. Remuneration and social security	454/9	--	17
F. Other amounts payable	47/48	3,707	28,580
<b>X. Accrued charges and deferred income</b>	<b>492/3</b>	<b>24,312</b>	<b>24,411</b>
<b><u>TOTAL LIABILITIES</u></b>	<b><u>10/49</u></b>	<b><u>265,089</u></b>	<b><u>285,284</u></b>

## 5.2 Income statement BE-GAAP for the financial years ended 31 December 2016 and 2015

<u>CHARGES (In thousand €)</u>	<u>Codes</u>	<u>TOTAL</u>	
		31/12/2016	31/12/2015
<b><u>II. Operating charges</u></b>	<b><u>60/66A</u></b>	<b><u>54,264</u></b>	<b><u>56,251</u></b>
A. Raw materials, consumables	60	24,801	25,595
1. Purchases	600/8	24,801	25,595
2. Decrease (increase) in stocks (+)/(-)	609	--	--
B. Services and other goods	61	19,174	19,585
C. Remuneration, social security costs and pensions	62	--	--
D. Depreciation of and amounts written off formation expenses, intangible and tangible fixed assets	630	8,618	9,294
E. Increase, Decrease in amounts written off stocks contracts in progress and trade debtors:			
Appropriations (write-backs) (+)/(-)	631/4	25	-22
F. Provisions for risks and charges - Appropriation (uses and write backs) (+)/(-)	635/8	-14	-14
G. Other operating charges	640/8	1,660	1,813
H. Operation charges carried to assets as restructuring costs (-)	649/6690	--	--
I. Non-recurring operating charges	66A	--	--
<b><u>III. Operating profit</u></b>	<b><u>9901</u></b>	<b><u>11,564</u></b>	<b><u>12,493</u></b>
<b><u>V. Financial charges</u></b>	<b><u>65/66B</u></b>	<b><u>4,700</u></b>	<b><u>4,825</u></b>
A. Recurring financial charges	65	4,700	4,825
1. Debt charges	650	4,699	4,824
2. Amounts written down on current assets except stocks, contracts in progress and trade debtors (+)/(-)	651	--	--
3. Other financial charges	652/9	1	1
B. Non recurring financial charges	66B	--	--
<b><u>VI. Profit for the period before taxes</u></b>	<b><u>9903</u></b>	<b><u>6,875</u></b>	<b><u>7,719</u></b>
<b><u>VII.B. Transfer to postponed taxes</u></b>	<b><u>680</u></b>	<b><u>--</u></b>	<b><u>--</u></b>
<b><u>VIII. Income taxes</u></b>			
A. Income taxes	<b><u>670/3</u></b>	<b><u>2,270</u></b>	<b><u>2,863</u></b>
	-	-	-
<b><u>IX. Profit for the period</u></b>	<b><u>9904</u></b>	<b><u>5,086</u></b>	<b><u>4,856</u></b>
<b>TOTAL</b>	<b><u>60/67</u></b>	<b><u>66,320</u></b>	<b><u>68,796</u></b>
<b><u>X.B. Transfer to untaxed reserves</u></b>	<b><u>689</u></b>	<b><u>--</u></b>	<b><u>--</u></b>

<b><u>XI. Profit for the period available for appropriation</u></b>	<b><u>9905</u></b>	<b><u>5,086</u></b>	<b><u>4,856</u></b>
---	--------------------	---------------------	---------------------

<b><u>INCOME (In thousand €)</u></b>	<b><u>Codes</u></b>	<b><u>TOTAL</u></b>	
		<b><u>31/12/2016</u></b>	<b><u>31/12/2015</u></b>
<b><u>I. Operating income</u></b>	<b><u>70/76A</u></b>	<b><u>65,828</u></b>	<b><u>68,744</u></b>
A. Turnover	70	57,950	66,317
B. Increase (decrease) in stocks of finished goods, work and contracts in progress (+)/(-)	71	-102	199
C. Own construction capitalised	72	--	--
D. Other operating income	74	7,980	2,228
E. Non-recurring operating income	76A	--	--
<b><u>III. Operating loss</u></b>	<b><u>9901</u></b>	<b><u>--</u></b>	<b><u>--</u></b>
<b><u>IV. Financial income</u></b>	<b><u>75/76B</u></b>	<b><u>11</u></b>	<b><u>51</u></b>
A. Recurring financial income	75	11	51
1. Income from financial fixed assets	750	0	0
2. Income from current assets	751	1	25
3. Other financial income	752/9	10	26
B. Non-recurring financial income	76B	--	--
<b><u>VI. Loss for the period before taxes</u></b>	<b><u>9903</u></b>	<b><u>--</u></b>	<b><u>--</u></b>
<b><u>VII.A. Transfer from postponed taxes</u></b>	<b><u>780</u></b>	<b><u>--</u></b>	<b><u>--</u></b>
<b><u>VIII. Income taxes</u></b>			
B. Adjustment of income taxes and write-back of tax provisions	<b><u>77</u></b>	<b><u>481</u></b>	<b><u>--</u></b>
<b><u>IX. Loss for the period</u></b>	<b><u>9904</u></b>	<b><u>--</u></b>	<b><u>--</u></b>
<b>TOTAL</b>	<b><u>70/77</u></b>	<b><u>66,320</u></b>	<b><u>68,796</u></b>
<b><u>X.A. Transfer from untaxed reserves</u></b>	<b><u>789</u></b>	<b><u>--</u></b>	<b><u>--</u></b>
<b><u>XI. Loss for the period available for appropriation</u></b>	<b><u>9905</u></b>	<b><u>--</u></b>	<b><u>--</u></b>

## 6. Gaselwest

### 6.1 Balance sheet BE-GAAP as of 31 December 2016 and 2015

<b>ASSETS (In thousand €)</b>	<b>Codes</b>	<b>TOTAL</b>	
		<b>31/12/2016</b>	<b>31/12/2015</b>
<b>I. Formation expenses</b>	<b>20</b>	--	--
<b><u>FIXED ASSETS</u></b>	<b><u>21/28</u></b>	<b><u>1,737,504</u></b>	<b><u>1,751,777</u></b>
<b>II. Intangible fixed assets</b>	<b>21</b>	<b>17,636</b>	<b>19,243</b>
<b>III. Tangible fixed assets</b>	<b>22/27</b>	<b>1,719,701</b>	<b>1,732,531</b>
A. Land and buildings	22	37,784	37,869
B. Plant, machinery and equipment	23	1,625,113	1,656,267
C. Furniture and vehicles	24	3,803	3,689
D. Leasing and other rights	25	--	--
E. Other tangible fixed assets	26	125	114
F. Assets under construction and advance payments	27	52,876	34,592
<b>IV. Financial fixed assets</b>	<b>28</b>	<b>167</b>	<b>3</b>
A. Affiliated enterprises	280/1	--	--
1. Participating interests	280	--	--
2. Amounts receivable	281	--	--
B. Other enterprises linked by participating interests:	282/3	167	3
1. Participating interests	282	167	3
2. Amounts receivable	283	--	--
C. Other financial assets	284/8	--	--
1. Shares	284	--	--
2. Amounts receivable and cash guarantees	285/8	--	--
<b><u>CURRENT ASSETS</u></b>	<b><u>29/58</u></b>	<b><u>430,816</u></b>	<b><u>408,956</u></b>
<b>V. Amounts receivable after more than one year</b>	<b>29</b>	<b>117</b>	<b>158</b>
A. Trade debtors	290	117	158
B. Other amounts receivable	291	--	--
<b>VI. Stocks and contracts in progress</b>	<b>3</b>	<b>7,216</b>	<b>8,125</b>
A. Stocks	30/36	--	--
1. Raw materials and consumables	30/31	--	--
2. Work in progress	32	--	--
3. Finished goods	33	--	--
4. Goods purchased for resale	34	--	--
5. Immovable property intended for sale	35	--	--

6. Advance payments	36	--	--
B. Contracts in progress	37	7,216	8,125
<b>VII. Amounts receivable within one year</b>	<b>40/41</b>	<b>233,193</b>	<b>230,725</b>
A. Trade debtors	40	86,961	62,082
B. Other amounts receivable	41	146,232	168,643
<b>VIII. Current investments</b>	<b>50/53</b>	<b>--</b>	<b>--</b>
A. Own shares	50	--	--
B. Other investments and deposits	51/53	--	--
<b>IX. Cash at bank and in hand</b>	<b>54/58</b>	<b>4</b>	<b>5</b>
<b>X. Deferred charges and accrued income</b>	<b>490/1</b>	<b>190,286</b>	<b>169,943</b>
<b><u>TOTAL ASSETS</u></b>	<b><u>20/58</u></b>	<b><u>2,168,320</u></b>	<b><u>2,160,733</u></b>

<b><u>EQUITY AND LIABILITIES (In thousand €)</u></b>	<b><u>Codes</u></b>	<b><u>TOTAL</u></b>	
		<b>31/12/2016</b>	<b>31/12/2015</b>
<b><u>EQUITY</u></b>	<b><u>10/15</u></b>	<b><u>662,797</u></b>	<b><u>657,206</u></b>
<b>I. Capital</b>	<b>10</b>	<b>271,034</b>	<b>272,550</b>
A. Issued capital	100	271,034	272,550
B. Uncalled capital (-)	101	--	--
<b>II. Share premium account</b>	<b>11</b>	<b>--</b>	<b>--</b>
<b>III. Revaluation surpluses</b>	<b>12</b>	<b>181,931</b>	<b>194,262</b>
<b>IV. Reserves</b>	<b>13</b>	<b>197,616</b>	<b>178,874</b>
A. Legal reserve	130	609	610
B. Reserves not available	131	22,994	10,663
1. In respect of own shares held	1310	--	--
2. Other	1311	22,994	10,663
C. Untaxed reserves	132	--	--
D. Available reserves	133	174,013	167,601
<b>V. Accumulated profits</b>	<b>140</b>	<b>11,476</b>	<b>11,520</b>
Accumulated (losses)	<b>141</b>	<b>--</b>	<b>--</b>
<b>V. bis Result of the year</b>		<b>--</b>	<b>--</b>
<b>VI. Investment grants</b>	<b>15</b>	<b>740</b>	<b>--</b>



Advance to associates on the sharing out of the assets	19	--	--
<b><u>PROVISIONS AND DEFERRED TAXES</u></b>	<b><u>16</u></b>	<b><u>6,953</u></b>	<b><u>7,467</u></b>
<b>VII. A. Provisions for liabilities and charges</b>	<b>160/5</b>	<b>6,572</b>	<b>7,467</b>
1. Pensions and similar obligations	160	--	--
2. Taxation	161	--	--
3. Major repairs and maintenance	162	--	--
4. Environmental liabilities	163	5,761	6,590
5. Other risks and costs	164/5	811	877
<b>B. Deferred taxes</b>	<b>168</b>	<b>381</b>	<b>--</b>
<b><u>AMOUNTS PAYABLE</u></b>	<b><u>17/49</u></b>	<b><u>1,498,570</u></b>	<b><u>1,496,060</u></b>
<b>VII. Amounts payable after more than one year</b>	<b>17</b>	<b>1,137,605</b>	<b>1,124,988</b>
A. Financial debts	170/4	1,137,605	1,124,988
1. Subordinated loans	170	--	--
2. Unsubordinated debentures	171	--	--
3. Leasing and other similar obligations	172	--	--
4. Credit institutions	173	1,137,605	1,124,988
5. Other loans	174	--	--
B. Trade debts	175	--	--
1. Suppliers	1750	--	--
2. Bills of exchange payable	1751	--	--
C. Advances received on contracts in progress	176	--	--
D. Other amounts payable	178/9	--	--
<b>IX. Amounts payable within one year</b>	<b>42/48</b>	<b>302,036</b>	<b>331,400</b>
A. Current portion of amounts payable after more than one year falling due within one year	42	66,183	181,998
B. Financial debts	43	86,870	44,285
1. Credit institutions	430/8	--	--
2. Other loans	439	86,870	44,285
C. Trade debts	44	69,537	57,536
1. Suppliers	440/4	69,537	57,536
2. Bills of exchange payable	441	--	--
D. Advances received on contracts in progress	46	10,485	10,084
E. Taxes, remuneration and social security	45	48,364	23,896
1. Taxes	450/3	48,364	23,896
2. Remuneration and social security	454/9	--	--
F. Other amounts payable	47/48	20,597	13,601
<b>X. Accrued charges and deferred income</b>	<b>492/3</b>	<b>58,929</b>	<b>39,672</b>
<b><u>TOTAL LIABILITIES</u></b>	<b><u>10/49</u></b>	<b><u>2,168,320</u></b>	<b><u>2,160,733</u></b>

## 6.2 Income statement BE-GAAP for the financial years ended 31 December 2016 and 2015

<u>CHARGES (In thousand €)</u>	<u>Codes</u>	<u>TOTAL</u>	
		31/12/2016	31/12/2015
<b><u>II. Operating charges</u></b>	<b><u>60/66A</u></b>	<b><u>419,601</u></b>	<b><u>430,156</u></b>
A. Raw materials, consumables	60	223,615	217,075
1. Purchases	600/8	223,615	217,075
2. Decrease (increase) in stocks (+)/(-)	609	--	--
B. Services and other goods	61	121,728	136,543
C. Remuneration, social security costs and pensions	62	--	--
D. Depreciation of and amounts written off formation expenses, intangible and tangible fixed assets	630	67,621	67,913
E. Increase, Decrease in amounts written off stocks contracts in progress and trade debtors:			
Appropriations (write-backs) (+)/(-)	631/4	-639	-218
F. Provisions for risks and charges - Appropriation (uses and write backs) (+)/(-)	635/8	-895	-104
G. Other operating charges	640/8	8,171	8,947
H. Operation charges carried to assets as restructuring costs (-)	649/6690	--	--
I. Non-recurring operating charges	66A	--	--
<b><u>III. Operating profit</u></b>	<b><u>9901</u></b>	<b><u>126,520</u></b>	<b><u>116,926</u></b>
<b><u>V. Financial charges</u></b>	<b><u>65/66B</u></b>	<b><u>42,662</u></b>	<b><u>44,131</u></b>
A. Recurring financial charges	65	42,662	44,131
1. Debt charges	650	42,643	44,104
2. Amounts written down on current assets except stocks, contracts in progress and trade debtors (+)/(-)	651	--	--
3. Other financial charges	652/9	19	27
B. Non recurring financial charges	66B	--	--
<b><u>VI. Profit for the period before taxes</u></b>	<b><u>9903</u></b>	<b><u>84,098</u></b>	<b><u>73,455</u></b>
<b><u>VII.B. Transfer to postponed taxes</u></b>	<b><u>680</u></b>	<b><u>--</u></b>	<b><u>--</u></b>
<b><u>VIII. Income taxes</u></b>			
A. Income taxes	<b><u>670/3</u></b>	<b><u>30,557</u></b>	<b><u>26,500</u></b>
<b><u>IX. Profit for the period</u></b>	<b><u>9904</u></b>	<b><u>53,626</u></b>	<b><u>46,955</u></b>
<b>TOTAL</b>	<b><u>60/67</u></b>	<b><u>546,446</u></b>	<b><u>547,742</u></b>
<b><u>X.B. Transfer to untaxed reserves</u></b>	<b><u>689</u></b>	<b><u>--</u></b>	<b><u>--</u></b>

<b><u>XI. Profit for the period available for appropriation</u></b>	<b><u>9905</u></b>	<b><u>53,626</u></b>	<b><u>46,955</u></b>
---	--------------------	----------------------	----------------------

<b><u>INCOME (In thousand €)</u></b>	<b><u>Codes</u></b>	<b><u>TOTAL</u></b>	
		<b><u>31/12/2016</u></b>	<b><u>31/12/2015</u></b>
<b><u>I. Operating income</u></b>	<b><u>70/76A</u></b>	<b><u>546,121</u></b>	<b><u>547,082</u></b>
A. Turnover	70	530,210	529,345
B. Increase (decrease) in stocks of finished goods, work and contracts in progress (+)/(-)	71	-909	-244
C. Own construction capitalised	72	--	--
D. Other operating income	74	16,820	17,981
E. Non-recurring operating income	76A	--	--
<b><u>III. Operating loss</u></b>	<b><u>9901</u></b>	<b><u>--</u></b>	<b><u>--</u></b>
<b><u>IV. Financial income</u></b>	<b><u>75/76B</u></b>	<b><u>240</u></b>	<b><u>660</u></b>
A. Recurring financial income	75	240	660
1. Income from financial fixed assets	750	0	0
2. Income from current assets	751	3	181
3. Other financial income	752/9	237	479
B. Non-recurring financial income	76B	--	--
<b><u>VI. Loss for the period before taxes</u></b>	<b><u>9903</u></b>	<b><u>--</u></b>	<b><u>--</u></b>
<b><u>VII.A. Transfer from postponed taxes</u></b>	<b><u>780</u></b>	<b><u>1</u></b>	<b><u>--</u></b>
<b><u>VIII. Income taxes</u></b>			
B. Adjustment of income taxes and write-back of tax provisions	<b><u>77</u></b>	<b><u>84</u></b>	<b><u>--</u></b>
<b><u>IX. Loss for the period</u></b>	<b><u>9904</u></b>	<b><u>--</u></b>	<b><u>--</u></b>
<b>TOTAL</b>	<b><u>70/77</u></b>	<b><u>546,446</u></b>	<b><u>547,742</u></b>
<b><u>X.A. Transfer from untaxed reserves</u></b>	<b><u>789</u></b>	<b><u>--</u></b>	<b><u>--</u></b>
<b><u>XI. Loss for the period available for appropriation</u></b>	<b><u>9905</u></b>	<b><u>--</u></b>	<b><u>--</u></b>

## 7. IMEA

### 7.1 Balance sheet BE-GAAP as of 31 December 2016 and 2015

<u>ASSETS (In thousand €)</u>	<u>Codes</u>	<u>TOTAL</u>	
		<u>31/12/2016</u>	<u>31/12/2015</u>
<b>I. Formation expenses</b>	<b>20</b>	--	--
<b><u>FIXED ASSETS</u></b>	<b><u>21/28</u></b>	<b><u>672,503</u></b>	<b><u>668,993</u></b>
<b>II. Intangible fixed assets</b>	<b>21</b>	<b>11,267</b>	<b>12,176</b>
<b>III. Tangible fixed assets</b>	<b>22/27</b>	<b>661,097</b>	<b>656,814</b>
A. Land and buildings	22	17,726	17,151
B. Plant, machinery and equipment	23	616,820	624,650
C. Furniture and vehicles	24	1,862	2,019
D. Leasing and other rights	25	--	--
E. Other tangible fixed assets	26	39	56
F. Assets under construction and advance payments	27	24,650	12,938
<b>IV. Financial fixed assets</b>	<b>28</b>	<b>139</b>	<b>3</b>
A. Affiliated enterprises	280/1	--	--
1. Participating interests	280	--	--
2. Amounts receivable	281	--	--
B. Other enterprises linked by participating interests:	282/3	139	3
1. Participating interests	282	139	3
2. Amounts receivable	283	--	--
C. Other financial assets	284/8	--	--
1. Shares	284	--	--
2. Amounts receivable and cash guarantees	285/8	--	--
<b><u>CURRENT ASSETS</u></b>	<b><u>29/58</u></b>	<b><u>191,548</u></b>	<b><u>217,314</u></b>
<b>V. Amounts receivable after more than one year</b>	<b>29</b>	<b>--</b>	<b>--</b>
A. Trade debtors	290	--	--
B. Other amounts receivable	291	--	--
<b>VI. Stocks and contracts in progress</b>	<b>3</b>	<b>6,288</b>	<b>19,850</b>
A. Stocks	30/36	--	--
1. Raw materials and consumables	30/31	--	--
2. Work in progress	32	--	--
3. Finished goods	33	--	--
4. Goods purchased for resale	34	--	--
5. Immovable property intended for sale	35	--	--

6. Advance payments	36	--	--
B. Contracts in progress	37	6,288	19,850
<b>VII. Amounts receivable within one year</b>	<b>40/41</b>	<b>51,664</b>	<b>53,985</b>
A. Trade debtors	40	34,939	32,754
B. Other amounts receivable	41	16,725	21,231
<b>VIII. Current investments</b>	<b>50/53</b>	<b>--</b>	<b>--</b>
A. Own shares	50	--	--
B. Other investments and deposits	51/53	--	--
<b>IX. Cash at bank and in hand</b>	<b>54/58</b>	<b>2</b>	<b>11,402</b>
<b>X. Deferred charges and accrued income</b>	<b>490/1</b>	<b>133,594</b>	<b>132,077</b>
<b><u>TOTAL ASSETS</u></b>	<b><u>20/58</u></b>	<b><u>864,051</u></b>	<b><u>886,307</u></b>

<b><u>EQUITY AND LIABILITIES (In thousand €)</u></b>	<b><u>Codes</u></b>	<b><u>TOTAL</u></b>	
		<b>31/12/2016</b>	<b>31/12/2015</b>
<b><u>EQUITY</u></b>	<b><u>10/15</u></b>	<b><u>286,543</u></b>	<b><u>284,882</u></b>
<b>I. Capital</b>	<b>10</b>	<b>126,071</b>	<b>126,071</b>
A. Issued capital	100	126,071	126,071
B. Uncalled capital (-)	101	--	--
<b>II. Share premium account</b>	<b>11</b>	<b>--</b>	<b>--</b>
<b>III. Revaluation surpluses</b>	<b>12</b>	<b>65,979</b>	<b>69,669</b>
<b>IV. Reserves</b>	<b>13</b>	<b>83,728</b>	<b>78,362</b>
A. Legal reserve	130	215	215
B. Reserves not available	131	7,547	3,856
1. In respect of own shares held	1310	--	--
2. Other	1311	7,547	3,856
C. Untaxed reserves	132	--	--
D. Available reserves	133	75,966	74,291
<b>V. Accumulated profits</b>	<b>140</b>	<b>10,765</b>	<b>10,780</b>
Accumulated (losses)	<b>141</b>	<b>--</b>	<b>--</b>
<b>V. bis Result of the year</b>		<b>--</b>	<b>--</b>
<b>VI. Investment grants</b>	<b>15</b>	<b>--</b>	<b>--</b>

Advance to associates on the sharing out of the assets	19	--	--
<b>PROVISIONS AND DEFERRED TAXES</b>	<b>16</b>	<b>--</b>	<b>64</b>
<b>VII. A. Provisions for liabilities and charges</b>	<b>160/5</b>	<b>--</b>	<b>64</b>
1. Pensions and similar obligations	160	--	--
2. Taxation	161	--	--
3. Major repairs and maintenance	162	--	--
4. Environmental liabilities	163	--	--
5. Other risks and costs	164/5	--	64
<b>B. Deferred taxes</b>	<b>168</b>	<b>--</b>	<b>--</b>
<b>AMOUNTS PAYABLE</b>	<b>17/49</b>	<b>577,508</b>	<b>601,361</b>
<b>VII. Amounts payable after more than one year</b>	<b>17</b>	<b>415,361</b>	<b>418,387</b>
A. Financial debts	170/4	415,361	418,387
1. Subordinated loans	170	--	--
2. Unsubordinated debentures	171	--	--
3. Leasing and other similar obligations	172	--	--
4. Credit institutions	173	415,361	418,387
5. Other loans	174	--	--
B. Trade debts	175	--	--
1. Suppliers	1750	--	--
2. Bills of exchange payable	1751	--	--
C. Advances received on contracts in progress	176	--	--
D. Other amounts payable	178/9	--	--
<b>IX. Amounts payable within one year</b>	<b>42/48</b>	<b>106,153</b>	<b>134,483</b>
A. Current portion of amounts payable after more than one year falling due within one year	42	37,226	70,136
B. Financial debts	43	14,723	--
1. Credit institutions	430/8	--	--
2. Other loans	439	14,723	--
C. Trade debts	44	24,209	24,972
1. Suppliers	440/4	24,209	24,972
2. Bills of exchange payable	441	--	--
D. Advances received on contracts in progress	46	8,585	23,051
E. Taxes, remuneration and social security	45	13,785	9,329
1. Taxes	450/3	13,785	9,329
2. Remuneration and social security	454/9	--	--
F. Other amounts payable	47/48	7,625	6,995
<b>X. Accrued charges and deferred income</b>	<b>492/3</b>	<b>55,994</b>	<b>48,491</b>
<b>TOTAL LIABILITIES</b>	<b>10/49</b>	<b>864,051</b>	<b>886,307</b>

## 7.2 Income statement BE-GAAP for the financial years ended 31 December 2016 and 2015

<u>CARGES (In thousand €)</u>	<u>Codes</u>	<u>TOTAL</u>	
		<u>31/12/2016</u>	<u>31/12/2015</u>
<b><u>II. Operating charges</u></b>	<b><u>60/66A</u></b>	<b><u>190,745</u></b>	<b><u>211,916</u></b>
A. Raw materials, consumables	60	90,473	91,512
1. Purchases	600/8	90,473	91,512
2. Decrease (increase) in stocks (+)/(-)	609	--	--
B. Services and other goods	61	63,565	83,208
C. Remuneration, social security costs and pensions	62	--	--
D. Depreciation of and amounts written off formation expenses, intangible and tangible fixed assets	630	30,988	32,772
E. Increase, Decrease in amounts written off stocks contracts in progress and trade debtors:			
Appropriations (write-backs) (+)/(-)	631/4	-375	-2,656
F. Provisions for risks and charges - Appropriation (uses and write backs) (+)/(-)	635/8	-64	-257
G. Other operating charges	640/8	6,158	7,337
H. Operation charges carried to assets as restructuring costs (-)	649/6690	--	--
I. Non-recurring operating charges	66A	--	--
<b><u>III. Operating profit</u></b>	<b><u>9901</u></b>	<b><u>40,577</u></b>	<b><u>45,737</u></b>
<b><u>V. Financial charges</u></b>	<b><u>65/66B</u></b>	<b><u>16,140</u></b>	<b><u>16,269</u></b>
A. Recurring financial charges	65	16,140	16,269
1. Debt charges	650	16,139	16,268
2. Amounts written down on current assets except stocks, contracts in progress and trade debtors (+)/(-)	651	--	--
3. Other financial charges	652/9	1	1
B. Non recurring financial charges	66B	--	--
<b><u>VI. Profit for the period before taxes</u></b>	<b><u>9903</u></b>	<b><u>24,528</u></b>	<b><u>29,643</u></b>
<b><u>VII.B. Transfer to postponed taxes</u></b>	<b><u>680</u></b>	<b><u>--</u></b>	<b><u>--</u></b>
<b><u>VIII. Income taxes</u></b>			
A. Income taxes	<b><u>670/3</u></b>	<b><u>7,636</u></b>	<b><u>10,249</u></b>
<b><u>IX. Profit for the period</u></b>	<b><u>9904</u></b>	<b><u>18,063</u></b>	<b><u>19,394</u></b>
<b>TOTAL</b>	<b><u>60/67</u></b>	<b><u>232,584</u></b>	<b><u>257,828</u></b>
<b><u>X.B. Transfer to untaxed reserves</u></b>	<b><u>689</u></b>	<b><u>--</u></b>	<b><u>--</u></b>

<b><u>XI. Profit for the period available for appropriation</u></b>	<b><u>9905</u></b>	<b><u>18,063</u></b>	<b><u>19,394</u></b>
---	--------------------	----------------------	----------------------

<b><u>INCOME (In thousand €)</u></b>	<b><u>Codes</u></b>	<b><u>TOTAL</u></b>	
		<b><u>31/12/2016</u></b>	<b><u>31/12/2015</u></b>
<b><u>I. Operating income</u></b>	<b><u>70/76A</u></b>	<b><u>231,322</u></b>	<b><u>257,653</u></b>
A. Turnover	70	234,063	234,420
B. Increase (decrease) in stocks of finished goods, work and contracts in progress (+)/(-)	71	-13,562	5,608
C. Own construction capitalised	72	--	--
D. Other operating income	74	10,821	17,625
E. Non-recurring operating income	76A	--	--
<b><u>III. Operating loss</u></b>	<b><u>9901</u></b>	<b><u>--</u></b>	<b><u>--</u></b>
<b><u>IV. Financial income</u></b>	<b><u>75/76B</u></b>	<b><u>91</u></b>	<b><u>175</u></b>
A. Recurring financial income	75	91	175
1. Income from financial fixed assets	750	--	--
2. Income from current assets	751	54	91
3. Other financial income	752/9	37	84
B. Non-recurring financial income	76B	--	--
<b><u>VI. Loss for the period before taxes</u></b>	<b><u>9903</u></b>	<b><u>--</u></b>	<b><u>--</u></b>
<b><u>VII.A. Transfer from postponed taxes</u></b>	<b><u>780</u></b>	<b><u>--</u></b>	<b><u>--</u></b>
<b><u>VIII. Income taxes</u></b>			
B. Adjustment of income taxes and write-back of tax provisions	<b><u>77</u></b>	<b><u>1,171</u></b>	<b><u>--</u></b>
<b><u>IX. Loss for the period</u></b>	<b><u>9904</u></b>	<b><u>--</u></b>	<b><u>--</u></b>
<b>TOTAL</b>	<b><u>70/77</u></b>	<b><u>232,584</u></b>	<b><u>257,828</u></b>
<b><u>X.A. Transfer from untaxed reserves</u></b>	<b><u>789</u></b>	<b><u>--</u></b>	<b><u>--</u></b>
<b><u>XI. Loss for the period available for appropriation</u></b>	<b><u>9905</u></b>	<b><u>--</u></b>	<b><u>--</u></b>



## ISSUER

### **Eandis System Operator CVBA**

Brusselsesteenweg 199  
9090 Melle  
Belgium

## GUARANTORS

### **Gaselwest, opdrachthoudende vereniging**

President Kennedypark 12  
8500 Kortrijk  
Belgium

### **Imea, opdrachthoudende vereniging**

Merksemsesteenweg 233  
2100 Deurne - Antwerp  
Belgium

### **Imewo, opdrachthoudende vereniging**

Brusselsesteenweg 199  
9090 Melle  
Belgium

### **Intergem, opdrachthoudende vereniging**

Franz Courtensstraat 11, administratief centrum  
9200 Dendermonde

### **Iveka, opdrachthoudende vereniging**

Koningin Elisabethlei 38  
2300 Turnhout  
Belgium

### **Iverlek, opdrachthoudende vereniging**

Aarschotsesteenweg 58  
3012 Wilsela - Leuven  
Belgium

### **Sibelgas, opdrachthoudende vereniging**

Sterrenkundelaan 13  
1210 Sint-Joost-Ten-Node  
Belgium

## JOINT LEAD MANAGERS

### **Belfius Bank NV/SA**

Pachecolaan 44  
1000 Brussels  
Belgium

### **BNP Paribas Fortis NV/SA**

Warandeborg 3  
1000 Brussels  
Belgium

## LEGAL ADVISERS

### **to the Issuer and the Guarantors**

### **Clifford Chance LLP**

Louizalaan 65, box 2  
1050 Brussels  
Belgium

### **to the Joint lead Managers**

### **Linklaters LLP**

Brederodestraat 13  
1000 Brussels  
Belgium

## AUDITORS OF THE ISSUER

### **Ernst & Young Bedrijfsrevisoren BCVBA**

represented by Mr P. Eelen  
De Kleetlaan 2  
1831 Diegem, Belgium

## AUDITORS OF THE GUARANTORS

### **to Gaselwest, IMEA, Imewo, Intergem, Iveka and Inverlek**

### **Ernst & Young Bedrijfsrevisoren BCVBA**

represented by Mr P. Eelen  
De Kleetlaan 2  
1831 Diegem, Belgium

### **To Sibelgas**

### **KPMG Bedrijfsrevisoren B.C.V.B.A.**

represented by Mr E. Clinck  
Prins Boudewijnlaan 24d  
2550 Kontich, Belgium